



**Eastern
Economy
Edition**

Third Edition

**ELEMENTS OF
CIVIL ENGINEERING
AND ENGINEERING
MECHANICS**

Ketabton.com

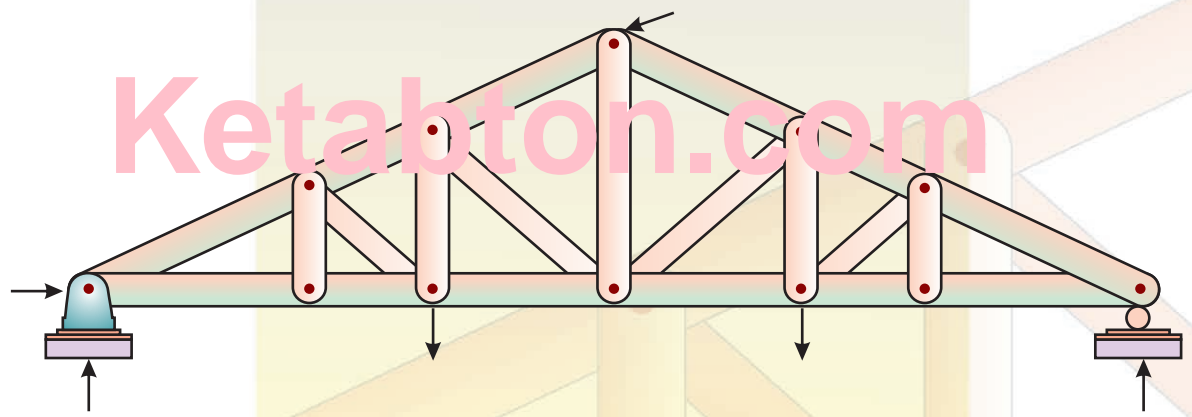

**M.N. SHESHA PRAKASH
GANESH B. MOGAVEER**

Elements of
**CIVIL ENGINEERING AND
ENGINEERING MECHANICS**

THIRD EDITION

M.N. SHESHA PRAKASH

Vice Principal
Professor and Head of Civil Engineering
Vidya Vikas Institute of Engineering and Technology
Mysore

GANESH B. MOGAVEER

Professor and Head, Department of Civil Engineering
Mangalore Institute of Technology and Engineering
Moodabidri

PHI Learning Private Limited

Delhi-110092

2014

www.engbookspdf.com

**ELEMENTS OF CIVIL ENGINEERING AND ENGINEERING MECHANICS, Third Edition
(with CD-ROM)**

M.N. Shesha Prakash and Ganesh B. Mogaveer

© 2014 by PHI Learning Private Limited, Delhi. All rights reserved. No part of this book may be reproduced in any form, by mimeograph or any other means, without permission in writing from the publisher.

The authors and the publisher make no warranty of any kind, expressed or implied, with regard to programs contained in this companion CD. The authors and publisher shall not be liable in any event for incidental or consequential damages in connection with, or arising out of, the furnishing, performance, or use of these programs.

ISBN-978-81-203-5001-4

The export rights of this book are vested solely with the publisher.

Fifth Printing (Third Edition)

...

...

August, 2014

Published by Asoke K. Ghosh, PHI Learning Private Limited, Rimjihim House, 111, Patparganj Industrial Estate, Delhi-110092 and Printed by Mohan Makhijani at Rekha Printers Private Limited, New Delhi-110020.

CONTENTS

Preface *vii*

Preface to the First Edition *ix*

Acknowledgements *xi*

1. Introduction to Civil Engineering 1–20

| | |
|---|----|
| What is Engineering? | 1 |
| Branches of Engineering | 1 |
| Civil Engineering | 2 |
| Civil Engineering for Civilization | 2 |
| Surveying | 2 |
| Fluid Mechanics and Hydraulics | 3 |
| Transportation Engineering | 3 |
| Water Resources Engineering | 4 |
| Environmental Engineering | 4 |
| Geotechnical Engineering | 4 |
| Foundation Engineering | 5 |
| Construction Technology—Built Environment | 5 |
| Infrastructure | 6 |
| Role of Civil Engineer | 7 |
| Roads and Highways | 7 |
| Types of Roads | 8 |
| Classification of Roads by Nagpur Road Plan | 9 |
| Dams | 11 |
| Bridges | 13 |
| Types of Bridges | 13 |
| <i>Exercise Problems</i> | 20 |

iv CONTENTS

| | |
|---|----------------|
| 2. Introduction to Engineering Mechanics | 21–33 |
| An Overview | 21 |
| Mechanics of Rigid Bodies | 21 |
| Mechanics of Deformable Bodies | 22 |
| Mechanics of Fluids | 22 |
| Force and Force System | 22 |
| Technical Terms Used in Engineering Mechanics | 22 |
| Newton’s Laws of Motion | 23 |
| Elements of a Force or Characteristics of a Force | 23 |
| Types of Force System | 24 |
| Principle of Transmissibility of Forces | 27 |
| Principle of Superposition of Forces | 27 |
| Principle of Physical Independence of Forces | 28 |
| Resolution of a Force | 28 |
| Composition of Forces | 28 |
| Moment of a Force | 31 |
| Couple | 32 |
| Exercise Problems | 33 |
| 3. Coplanar Concurrent Force System | 34–50 |
| Definition | 34 |
| Problems on Coplanar Concurrent Force System | 35 |
| Exercise Problems | 47 |
| 4. Coplanar Non-concurrent Force System | 51–71 |
| Definition | 51 |
| Problems on Coplanar Non-concurrent Force System | 52 |
| Tips to Solve the Problems | 52 |
| Exercise Problems | 66 |
| 5. Equilibrium of Coplanar Concurrent Force System | 72–108 |
| Equilibrium | 72 |
| Problems on Equilibrium of Coplanar Concurrent Force System | 74 |
| Tips to Solve the Problems | 74 |
| Exercise Problems | 101 |
| 6. Equilibrium of Coplanar Non-concurrent Force System | 109–131 |
| Support Reactions | 109 |
| Types of Supports | 109 |
| Types of Beams | 110 |
| Types of Loads | 111 |

| | |
|---|----------------|
| Problems on Equilibrium of Coplanar Non-concurrent Force System | 112 |
| Tips to Solve the Problems | 112 |
| Exercise Problems | 129 |
| 7. Plane Trusses | 132–169 |
| Engineering Structure | 132 |
| Classification of Trusses | 132 |
| Analysis of Statically Determinate Trusses | 133 |
| Exercise Problems | 164 |
| 8. Friction | 170–210 |
| Introduction | 170 |
| Limiting Friction | 171 |
| Coefficient of Friction (μ) | 171 |
| Types of Friction | 171 |
| Angle of Friction (ϕ) | 172 |
| Angle of Repose (θ) | 173 |
| Cone of Friction | 174 |
| Laws of Friction | 174 |
| Tips to Solve the Problems | 175 |
| Wedge Friction | 195 |
| Ladder Friction | 202 |
| Exercise Problems | 207 |
| 9. Centroid of Plane Figures | 211–247 |
| Centre of Gravity | 211 |
| Centroid (C.G. or G) | 211 |
| Determination of Centroid by the Method of Moments | 212 |
| Axes of Reference | 212 |
| Centroidal Axis | 213 |
| Symmetrical Axis | 213 |
| Centroids of Some Important Geometrical Figures | 215 |
| Derivation of Centroid of Some Important Geometrical Figures | 217 |
| Problems on Centroid | 222 |
| Exercise Problems | 244 |
| 10. Moment of Inertia | 248–273 |
| Introduction | 248 |
| Parallel Axis Theorem | 249 |
| Perpendicular Axis Theorem | 250 |

vi CONTENTS

| | |
|---|----------------|
| Moment of Inertia of Important Figures | 251 |
| Rectangle | 251 |
| Triangle | 251 |
| Circle | 253 |
| Semicircle | 253 |
| Quarter Circle | 254 |
| Problems on Moment of Inertia | 255 |
| Steps to Solve any Given Problem | 255 |
| <i>Exercise Problems</i> | 270 |
| 11. Kinematics | 274–333 |
| Introduction to Dynamics | 274 |
| Technical Terms Related to Motion | 274 |
| Displacement and Distance Travelled | 275 |
| Average Acceleration | 276 |
| Newton's Laws of Motion | 276 |
| Types of Motion | 276 |
| Rectilinear Motion | 280 |
| Problems on Kinematics | 281 |
| Motion under Gravity | 290 |
| Curvilinear motion | 296 |
| Introduction | 296 |
| Curvilinear Motion in Cartesian Coordinates | 296 |
| Curvilinear Motion in Polar Coordinates | 310 |
| Projectiles | 317 |
| <i>Exercise Problems</i> | 329 |
| | |
| <i>Annexure 1: Useful Relationships</i> | 335–340 |
| <i>Annexure 2: Elements of Civil Engineering and Mechanics (4:0:0) ...</i> | 341–343 |
| <i>Objective Type Questions</i> | 345–370 |
| <i>Examination Papers of VTU</i> | 371–473 |
| <i>Solutions to the Examination Papers of VTU</i> | 475–543 |
| <i>Index</i> | 545–547 |

PREFACE

A new chapter on Kinematics has been included in this edition. Numerous problems have been included along with its solutions for the beginners to understand the concept better. The companion CD has been updated and the dynamic graphics part has been included for forces module, wherein the readers can have a feel of the force and its inclination through visualized graphics part. In addition to this, all other software modules are also updated for better usage.

We whole-heartedly thank all the faculty members and students who have suggested corrections, some of which have been incorporated in the third edition. We are also indebted to the wonderful team of PHI Learning which worked for the printing and marketing of this book.

**M.N. Shesha Prakash
Ganesh B. Mogaveer**

PREFACE TO THE FIRST EDITION

The purpose of this book is to focus on introductory material pertaining to **civil engineering** and **engineering mechanics** in order to provide the first-year students of all branches with a balanced and cohesive study of these two areas as needed by them in the beginning of their engineering education. It offers the basic knowledge about various facets of civil engineering (being the oldest branch of engineering) and the related engineering structures and infrastructure such as buildings, roads, highways, dams, and bridges which exist all around us. It also briefly explains the broad scope of allied fields of civil engineering such as surveying, transportation, water resources, environmental engineering, geotechnical engineering, foundation engineering and construction technology.

The engineering mechanics portion of the book has been thoroughly explained with many practical examples and an effort has been made to make the students learn the basic concepts, which will prove useful to them in their future endeavours of higher studies.

The topics in engineering mechanics are organized into Forces, Centroid, Moment of Inertia and Friction. Each chapter is written in such a way that the concepts are introduced to the reader gradually and stepwise. Each chapter consists of many worked-out problems so that several different types of problems get covered.

This book has also been provided with a CD wherein mini softwares are available to work out the problems on topics of Forces, Centroid, Moment of Inertia and Friction. The software is developed using MS Excel. The provision of such software overcomes restrictions on the number of problems available and this helps both the students and the faculty in several ways. The faculty can develop new types of problems with guaranteed and reliable solutions, thus helping them to set new type of questions for tests and examinations. At the same time the perusal of software helps the students to understand the fundamentals of the subject in a relatively easy manner.

This book has been written in a simple and easy-to-follow language. It uses step-by-step procedures to solve problems along with adequate theory as required by the first-year engineering students. Though especially designed to conform to the syllabus of Visvesaraya Technological University (VTU), it is a basic undergraduate textbook that will be useful to several other universities. The authors invite constructive criticism and suggestions from all readers for effecting improvements in subsequent editions.

**M.N. Shesha Prakash
Ganesh B. Mogaveer**

ACKNOWLEDGEMENTS

Writing a book is always a monumental effort, and it is my great pleasure to acknowledge the people who inspired me to complete this task.

I am indebted to the Principal and the Management, Vidya Vikas Institute of Engineering and Technology, Mysore, for their constant encouragement and help in all my endeavours to write this book.

I am obliged to my wife Dr. Gayathri Prakash and dear daughter Ms. Aradhana M Prakash, for their utmost cooperation and patience during my long outings with the manuscript.

I thank critics and readers who have helped me to correct the first and second editions already published.

I welcome readers for their suggestions for the improvement of the book.

M.N. Shesha Prakash

I am indebted to our honorable Chairman Sri Rajesh Chouta, our beloved Principal Dr. G.L. Easwara Prasad and all the staff members of Mangalore Institute of Technology and Engineering, Moodabidri, for their constant support in bringing the new edition of this book.

I am obliged to my family members Jyothi Ganesh, Akash, Avani and also my parents for their valuable cooperation and support.

Ganesh B. Mogaveer

We are grateful to the publisher, PHI Learning, for bringing out the third edition of this book in record time. Our special thanks to Mr. Darshan, Ms. Babita, Ms. Ruchira, Mr. Chandira Devadiga, Mr. Prabhakara Reddy and Mr. Arun and all those who have been responsible in publication and marketing our book.

**M.N. Shesha Prakash
Ganesh B. Mogaveer**

INTRODUCTION TO CIVIL ENGINEERING

WHAT IS ENGINEERING?

The basic needs of the human being are water, food, clothing and shelter. With rapid industrialization and urbanization, fresh and unpolluted air has become the added necessity of the urbanites. To fulfil these needs, different works are executed. Engineering is comprised of the execution of such works. The branch of knowledge which deals with various industrial processes is defined as the *technology*. The technology is a systematic knowledge of industrial processes.

Engineering can be defined as the role of directing the resources of nature to the use and convenience of man. Technology is an application of basic scientific knowledge to advancement.

BRANCHES OF ENGINEERING

The major branches of engineering are:

1. Civil Engineering
2. Mechanical Engineering
3. Electrical Engineering
4. Electronics
5. Telecommunication Engineering
6. Computer Engineering
7. Information Technology
8. Instrumentation
9. Metallurgy
10. Chemical Engineering
11. Mining

2 ELEMENTS OF CIVIL ENGINEERING AND ENGINEERING MECHANICS

CIVIL ENGINEERING

It is the first basic branch of engineering. Its relation to the fulfillment of human needs is direct, whereas the other engineering branches are complementary to the function of civil engineering. Civil engineering is called the general engineering because civil engineering uses the principles and information provided by other branches of engineering while erecting civil engineering structures.

CIVIL ENGINEERING FOR CIVILIZATION

Civilization is not built by bricks and mortar but by the men and women. Civilization is the average intellectual level of this population based on their educational standards and outcomes thereof to analyse a given problem on happening of a thing/event in a correct perspective.

In the olden days, the word Military Engineer originated first as he undertook the engineering tasks with reference to military's role in the war. The engineer undertaking works other than military engineering was referred to as a Civil Engineer. By civil engineering, we mean the engineering know-how and the tasks undertaken for the purpose of the civil population. Engineer and a civil engineer lay in the TIME resource.

Surveying

The study of surveying enables the engineer to determine relative positions of points on the surface of earth. Before the construction of any structure, surveying of the land, on which the construction is to come up, is always done. From the field observations in surveying taken in the horizontal plane, a plan is prepared of the existing features of ground and relative positions of points in the vertical plane are shown by sections, obtained by taking measurements in the vertical plane, termed levelling.

Classification of surveying

Surveying is classified into two broad categories:

1. Plane surveying
2. Geodetic surveying.

Plane surveying: In this type of surveying, the effect of curvature of the surface of earth is not taken into account. The surface of earth is taken to be a plane surface. The extent of area up to which this assumption of plane surface holds good is 260 sq.km. Therefore, plane surveying is adopted for small areas. The degree of accuracy of plane survey is relatively low.

Geodetic surveying: In geodetic surveying the curvature of the earth's surface is taken into account. Geodetic surveys are carried out for large distances and areas with a high degree of precision. In India, Survey of India, a Government department, undertakes the work of geodetic surveying.

General classification of surveying

Surveys are generally classified on the basis of purpose of the survey and the instruments used for surveying.

Classification based on the purpose of surveying

Topographical surveys: These surveys are carried out to locate the natural and artificial features on the surface of earth, such as rivers, hills, lakes, roads, railways, towns, villages, etc.

Cadastral surveys: These surveys are required for determining the boundaries of fields, houses and other properties to a larger scale.

City surveys: These surveys are carried out for laying out the boundaries of plots for the location of water supply and sewer lines.

Mine surveys: In this survey the underground mineral wealth such as iron ores, coal, gold, etc. are explored.

Classification based on the instrument used for surveying

1. Chain survey
2. Compass survey
3. Chain and compass survey
4. Theodolite survey
5. Tachometric survey
6. Plane table survey
7. Electronic distance meter survey.

Purpose of surveying

1. Surveying is necessary for preparing the plans which are the projections of any object on the horizontal plane. The differences in height are denoted by contour lines.
2. Surveying is necessary for planning the design of any engineering work. The accuracy of surveying influences the success and governs the economy of the project.

Fluid Mechanics and Hydraulics

It is a branch of science in which the study of fluids, i.e. liquids and gases, at rest and in motion is done. Usually, the liquid is water and the subject is titled *hydraulics*. When the water is at rest, the forces exerted by the water on immersed areas are found out by the laws of mechanics. Thus, the knowledge of these forces is useful in the design of the gates used to control the flood water in case of dams. When water is drawn off from a reservoir and conveyed through closed conduits or open channels, the knowledge of the behaviour of liquids in motion is useful here. Thus in the design of water supply distribution systems, the study of fluid mechanics helps to solve the problems encountered in the design. Certain machines which work on the water are used for the generation of electricity and are termed hydraulic machines. Knowledge of fluids mechanics is useful in designing these machines so that they give the best possible output.

Transportation Engineering

This subject deals with the transport of men and materials through different communication routes such as land, water and air. The railways and roads are the important modes of communication by land. The water transport is feasible only where the rivers, canals are navigable or where the sea coast is available. Transportation by air routes is also increasing day by day. The transportation of

4 ELEMENTS OF CIVIL ENGINEERING AND ENGINEERING MECHANICS

men and goods for short distances can be speedily done by road transport, whereas railway transport is considered safe and convenient for long distances. The knowledge of surveying and levelling is very useful before deciding the alignments of roads or railway. The preparation of contour plan of a hilly region obtained from a levelling operation is useful in deciding the alignment of hill roads. The knowledge of surveying and levelling enables the engineer to decide the alignment of tunnels, which become necessary when the road or railway transportation is to be done through the hilly regions.

Water Resources Engineering

Water is such a commodity that it is vital for the existence of mankind. Human beings, animals and plants require water for their survival. Surface water is easy and economical to harness, however, its availability cannot be relied upon continuously since it varies with the season. Water Resources Engineering can be defined as the science which deals with the subject of tapping water either from the surface or subsurface sources. A water resource is such a vast subject that it includes in itself hydrology, irrigation, hydraulics and water supply. Tremendous volume of water is stored in the earth's crust. According to one estimate the total volume stored under the surface of earth may be about 80 million km cube, half of which may be at depths less than 600 m. The use of surface water for irrigation is likely to create problems like waterlogging in certain areas. Groundwater is obtainable all the year round and its use along with the surface water keeps the subsoil water level within reasonable limits. The judicious use of water for purposes of irrigation has gained such importance in the recent times that water management has become a science in itself. Engineers have learnt to tame the water resources by construction of dams, construction of bore wells and construction of hydroelectric plants for the benefit of mankind.

Environmental Engineering

This is an important branch of civil engineering which covers both water supply and sanitary engineering. The importance of clean environment was felt with the rapid growth in population, and the growth in urbanization and industries. Environment is polluted through the mediums of air, water or such other agents. The science of civil engineering deals with the subject of tapping water from different sources, testing its quality, purification processes and distribution of water to the consumers. Similarly the environmental engineering encompasses the subject of treatment of wastes which originate from different sources and deals with the removal of harmful substances in these wastes by different processes. The impact of wastes originating from industries is felt by living organisms if such wastes contain toxic substances. The Central Government as well as state governments have enacted laws for the protection of environment needed for the safe living of human beings.

Geotechnical Engineering

This branch of civil engineering is also called soil mechanics. It is a discipline of civil engineering in which the study of soil, its behaviour on the application of load and its use as an engineering material in the construction of earth dams, is done. The properties and strength characteristics of different types of soil are studied in this subject. The knowledge of this subject is useful in the design of earth dams, different pile foundations, buildings, foundations, etc.

Foundation Engineering

It is a branch of civil engineering in which the design, construction of different types of footings, foundations of walls, pile foundations of buildings and other engineering structures are studied. This study is of vital importance for foundations of buildings since there is a vertical rise of buildings due to limited space. The study of foundation engineering is complementary in nature while studying geotechnical engineering.

Construction Technology—Built Environment

A suitable environment is created by constructing a building. The building technology covers the planning of different units of a building to provide a suitable environment for the activities designed for the building. Codes of building bye-laws ensure good and sound construction through regulating the materials and construction methods. Climatic influence on the built environment is vital for minimum energy consumption. The building technology also covers the maintenance and repairs of the buildings and their safe demolition when they become too old to be used further.

The buildings are classified according to functions such as:

1. Residential buildings
2. Public buildings
3. Commercial buildings
4. Industrial buildings
5. Recreation buildings
6. Educational buildings
7. Hospital buildings
8. Storage, i.e. warehouses, etc.
9. Special purpose buildings, non-conventional buildings.

Building technology deals with the analysis and design of substructures as well as superstructures of buildings. It includes the study of different construction materials in respect of their properties and construction techniques. Some of the building materials are metals, timber, concrete, bituminous materials, bricks, soil, polymers and plastics, etc.

Construction technology and its management

The scope of 'construction' is more comprehensive here than that is in building technology. Based on sound principles of soil mechanics, foundations to non-conventional structures are covered under construction technology. It is comprised of different techniques of construction for different materials under different site conditions. The study of construction machinery comes under its purview. The management or organization of men (labour), materials, methods in relation to site, money and time is the backbone of construction management. It involves almost every branch of engineering, commerce and economics, for its ultimate aim is to 'achieve the desired construction in the most economic way'. A clear knowledge of the following points is necessary for reliable construction and its management.

The ten Ms of construction management are:

- (a) Money, Materials, Machines, Manpower, Methodologies,
- (b) Maintenance, Modernization, Monitoring, Motivations,
- (c) Managements of all types.

The study of this branch of civil engineering is beyond the scope of this book.

6 ELEMENTS OF CIVIL ENGINEERING AND ENGINEERING MECHANICS

Building materials

The materials required for the construction of structures are called either civil engineering materials or building materials. It is very essential for an engineer, builder, architect and contractor to be thoroughly conversant with these building materials. The knowledge of different types of materials, their properties and uses for different purposes is very essential for the builder in achieving overall economy.

Building materials account for about 70% of the total cost of construction. Thus, it is important that the building materials are easily and cheaply available.

Some of the building materials are:

1. **Bricks:** A brick is a rectangular block of regular shape obtained by moulding the mixture of clay and sand, which is then generally burnt at a high temperature.
2. **Rubble or stone:** A building stone or rubble is a natural material quarried from geological rock formations of igneous, sedimentary or metamorphic type. When quarried, stones are irregular in shape and have rough surface. Irregular stones are brought to the required size and shape and the process is called the dressing of stone. These dressed stones or rubbles are used in stone masonry.
3. **Aggregates:** Aggregates are chemically inert materials, such as crushed stone, gravel, sand, broken bricks, blast furnace slag, etc., obtained naturally or by crushing.
4. **Cement:** Cement is a binding material used in preparing cement mortar or concrete.
5. **Alternative building materials:** Traditional materials have a limited use for heavy constructions and therefore there is a need to develop new materials. Hence to reduce the cost of construction and to increase the strength, alternative building materials are used, for example, mud blocks, concrete blocks (solid or hollow), ferro cement, etc.
6. **Composite materials:** When two or more materials are combined to act as a single material, it is called the composite material, for example, wood laminates, plastic laminates, asbestos cement sheet, reinforced glass, etc.
7. **Smart materials:** These are materials which exhibit a change in their non-mechanical properties like thermal, optical, electrical or magnetic because of changes in the mechanical stimulus.

Infrastructure

The economic development of a country depends on the growth and production rate of industries and agricultural fields. This in turn depends upon the facilities such as transportation, energy, communication, science and technology, irrigation facilities, equipment and machinery. These facilities are referred to as *infrastructural facilities*.

Impact of infrastructural development on a country

Infrastructural development has the following major impacts on a country.

1. Increase in food production
2. Protection from famine

3. Safe, domestic and industrial water supply
4. Improvement in communication and transportation
5. Generation of hydroelectric power
6. Addition to the wealth of the country
7. Increase in prosperity of people
8. Overall development of the country.

Role of Civil Engineer

The success of civil engineering depends on how effectively the civil engineer plays his role. He has many jobs to attend to. Apart from being a technician, he has to coordinate the complex activities as a project manager to achieve the goals set by the owner.

Some of the duties of CIVIL ENGINEER are:

1. Reporting to managers, consultants and owner the progress of the work
2. Discussing anticipated problems and finding solutions
3. Providing general supervision to field activities
4. Guiding and monitoring the control systems for projects
5. Providing emergency/specific advice to field managers and staff
6. Deciding the type of site layout and levelling requirements
7. Arranging for all permissions required for executing the project work
8. Managing, coordinating and supervising the work of the site-contractors
9. Programming for schedule, performance and cost control management
10. Maintaining day-to-day records, registers, and keeping the necessary records for change orders.
11. Developing guidelines for industrial contractors and coordinating performances of all contractors.
12. Fulfilling job safety requirements.
13. Explaining designs, working drawings and specifications, project status and preparing project reports.

The civil engineer should have an overall experience. The overall experience consists of:

- (a) The construction experience
- (b) Knowledge of contracting methods
- (c) Knowledge of project management
- (d) The financial status of the project
- (e) Structure of the organization in which the civil engineer works
- (f) Liaison with previous and present clients.

Roads and Highways

Roads provide transportation facilities from one place to another. Roads are considered the most important infrastructure required for the development of a region. Figure 1.1 shows the cross section of a two-line highway in cutting and Figure 1.2 shows the cross section of a two-line highway in embankment.

8 ELEMENTS OF CIVIL ENGINEERING AND ENGINEERING MECHANICS

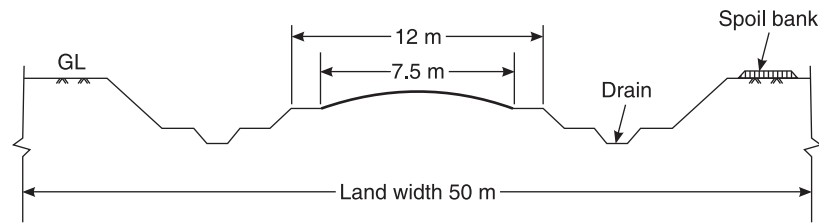

Figure 1.1 Cross section of a two-lane highway in cutting.

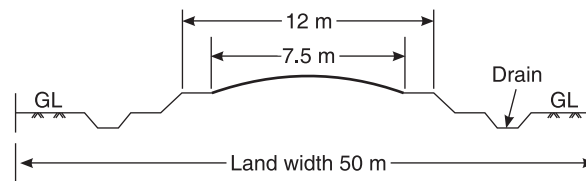

Figure 1.2 Cross section of a two-lane highway in embankment.

Types of Roads

The types of roads constructed are:

1. Low cost roads (earth roads, kankar roads, gravel roads, mourum roads, water-bound Macadam roads)
2. Bituminous roads (flexible pavements)
3. Cement-concrete roads (rigid pavements).

Low cost roads

The term low cost road is used to mean the road whose initial as well as maintenance costs are low. India is a country of villages and it is necessary to provide the facility of a linking road to every village. The low cost roads are meant for low intensity of traffic.

Bituminous roads

The bitumen, or bituminous materials in the form of tar or asphalt, is one of the major highway construction materials. The useful qualities of bitumen are:

- (i) It is an excellent binding material
- (ii) It gives an impermeable surface
- (iii) It softens when heated.

The consistency of bituminous materials ranges from semi-solid to liquid and these materials are made commercially available to suit the requirements of specifications for various types of bituminous roads.

A bituminous road is defined as a road in which bitumen is used in one form or the other as a binder to keep together the coarse aggregates and road metal. Such a road is also sometimes referred to black-top road because it exhibits a black appearance due to the presence of bitumen.

The advantages of bituminous roads are:

- (i) Bituminous materials increase the strength of pavement.
- (ii) Development of the cracks on the surface of the bitumen is very less.

- (iii) Maintenance costs of bituminous roads are less.
- (iv) Bituminous materials provide waterproof surface.
- (v) The surface of bituminous roads is non-slippery.
- (vi) Bituminous materials can effectively resist the adverse effect of rain, changes in temperature and wind.
- (vii) When the bituminous layer is provided on the top of an existing low cost road, it eliminates the dust nuisance.
- (viii) Bituminous materials provide smooth, durable and comfortable surface for traffic.

The disadvantages of bituminous roads are:

- (i) The construction cost is very high.
- (ii) The viscosity of the bitumen aggregate mixtures plays an important role in determining the performance of bituminous roads. So it is necessary to have control on the proper viscosity of the bitumen aggregate mixtures during mixing and compaction operations while constructing the road.

Cement-concrete roads

The cement-concrete roads are in the form of monolithic slabs of cement concrete, which serve two functions simultaneously, namely;

- (i) As the load carrying base
- (ii) As the wearing surface.

The cement-concrete roads are becoming popular because of the fact that concrete of desired quality can be prepared by modern techniques of cement-concrete construction.

The advantages of a cement-concrete road are:

- (i) It does not develop corrugations and hence provides a noiseless surface.
- (ii) It can be designed for more accurate load distribution.

The disadvantages are:

- (i) It is difficult to repair and needs expert supervision.
- (ii) It is liable to crack, warp and twist.

Classification of Roads by Nagpur Road Plan

The classification based on location and function is a more acceptable classification. According to Nagpur plan, five different categories of roads are as follows:

1. **National Highways (NHs):** National highways are the main highways running through the length and breadth of the country, connecting major ports, foreign highways, capitals of large states and large industrial and tourist centres including roads required for strategic movements of troops.
2. **State Highways (SHs):** State highways are the arterial roads of a state, connecting with the national highways, capitals of adjacent states, district headquarters and important cities within the state. A state highway serves as a connecting link for traffic to and from district roads.

10 ELEMENTS OF CIVIL ENGINEERING AND ENGINEERING MECHANICS

3. **Major District Roads (MDRs):** Major district roads are the important roads within a district, serving areas of production and market and connecting them with each other or with main highways of a district.
4. **Other District Roads (ODRs):** Other district roads are the roads serving the rural areas of production and providing them with an outlet to market centres, Taluka headquarters.
5. **Village Roads (VRs):** Village roads are the roads connecting villages or the groups of villages with each other to the nearest road of higher category.

Components of roads and their functions

Just like other structures, the highway or the road structure is also required to be designed carefully for the traffic load to be carried, physical and geological features, and climatic conditions of the locality and various other factors which would affect the stability and utility of the highway. For the purpose of design, the road structure may be considered to consist essentially of the following four component parts as shown in Figure 1.3.

1. Subsoil
2. Subgrade
3. Base
4. Surfacing.

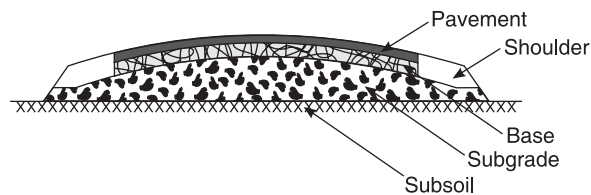

Figure 1.3 Component parts of road structure.

Subsoil: This is the natural or prepared soil on which the road has to be formed. It should be stable and strong to carry safely the traffic load and weight of roadway construction.

Subgrade: The subgrade or the formation functions as a support to the road surface and its foundation. The life of the road primarily depends on stable and dry subgrade. Its level may be same or above or below the natural ground level. The support given to the road structure by the subgrade is an important factor and hence, considerable attention should be paid to the proper preparation of subgrade before the road structure is laid on it.

Base: The base or foundation may consist of two layers, the bottom layer being known as sub-base or soling or bottoming. The sub-base should be stable and it should be capable of resisting distortion under traffic loads to a great extent. The function of a road base is to transmit the load from the surfacing to the subgrade. It should possess structural stability and should be of sufficient thickness to develop a good bond with the surfacing.

Surfacing: The topmost layer on which the traffic directly travels is known as road surfacing or wearing layer or wearing course. The main function of road surfacing is to provide a smooth and stable running surfacing which is suitable for the type and intensity of traffic anticipated on the road. The surfacing should be impervious and should protect the base and the subgrade from the

action of weather and rain water. The desirable qualities of surfacing are durability, stability, non-slipperiness, economical and dustlessness. It should also be able to resist displacement by traffic and should therefore must be well keyed on to the base.

The governing factors which would affect the design of the the above components of road structure are initial cost, availability of local materials, volume and class of traffic, climatic conditions of the locality, etc.

Dams

A dam is an impervious hydraulic structure constructed across a river to store water on the upstream side. It acts as a barrier to form a reservoir.

Dams may be classified into different categories depending upon the purpose they serve or on the basis of the material used for construction.

Classification according to use

Storage dam: A storage dam is constructed to store water on its upstream side during the period of excess supply and use it during the period of scarcity.

Diversion dam: A diversion dam raises the water level slightly in the river, and thus water is diverted into a canal system. A diversion dam is always smaller in height and no reservoir is formed on its upstream to store water.

Detention dam: A detention dam is constructed to store water during floods, in order to be able to release water gradually at a safe rate when the flood recedes. By the provision of a detention dam, damages downstream due to flood are reduced.

Classification according to material

Rigid dam: Rigid dams are those which are constructed of rigid material such as masonry, concrete, steel or timber.

Non-rigid dam: Non-rigid dams are those which are constructed of non-rigid materials such as earth and/or rock fill.

Classification according to flow condition

Overflow dam: If water is allowed to flow over the top of the dam, it is known as overflow dam. Such dams are also known as spillways. Gates are normally provided over spillways for allowing the water to pass downstream during floods and for extra storage of water after the floods.

Non-overflow dams: If water is not allowed to flow over the top of the dam, it is known as a non-overflow dam.

All the dams are generally a combination of overflow and non-overflow dams.

Gravity dams (Rigid dams)

A gravity dam is one in which the external forces (such as water pressure, silt pressure, wave pressure, etc.) are resisted by the self-weight of the dam. Thus the weight of the dam or the gravity forces maintain the stability of the dam. A gravity dam may be constructed either of masonry or concrete. Figure 1.4 shows a typical cross section of a concrete gravity dam.

12 ELEMENTS OF CIVIL ENGINEERING AND ENGINEERING MECHANICS

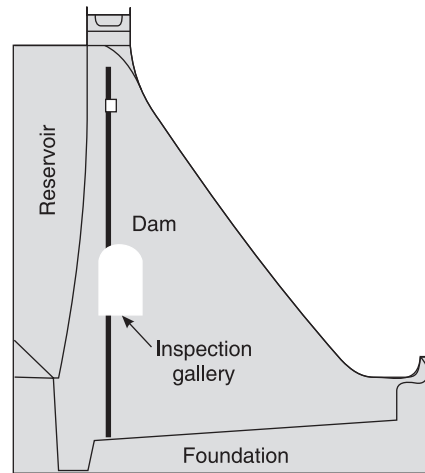

Figure 1.4 Cross section of a concrete gravity dam.

The different terms of importance are as follows:

1. **Maximum water level or full reservoir level:** The maximum level to which the water rises during the worst flood is known as the maximum water level or full reservoir level.
2. **Minimum pool level:** The lowest water surface elevation up to which the water in the reservoir can be used is called the minimum pool level.
3. **Normal pool level:** It is the maximum elevation to which the reservoir water surface will rise during normal operating conditions.
4. **Useful and dead storage:** The volume of water stored in the reservoir between the minimum pool level and normal pool level is called useful storage. The volume of water stored in the reservoir below the minimum pool level is known as dead storage.
5. **Free board:** The margin between the maximum water level and top of the dam is known as free board. Free board must be provided to avoid the possibility of water spilling over the top of the dam due to wave action.
6. **Drainage gallery:** A gallery provided near the foundation to drain off the water which seeps through the foundation and the body of dam is called the drainage gallery.

Earth dams and rockfill dams (Non-rigid dams)

Earth dams are constructed using the locally available soils and gravels; they can be used up to moderate heights only. Figure 1.5 shows a typical section of an earth dam.

Earth dams may be classified into:

1. Homogeneous type dams
2. Zoned type dams
3. Diaphragm type dams.

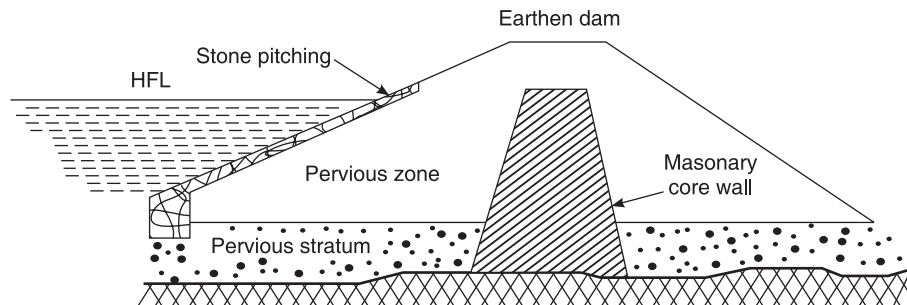

Figure 1.5 Section of an earth dam.

Bridges

Introduction

Bridges are an integral part of the infrastructure for the economic growth of the country and therefore they cannot remain static in relation to a growing economy. With the increase in population and growth in industrial and agricultural output, bridges along with railways have to keep pace with the developments through provision of transport facilities in areas where these have been lacking and increased facilities where these are inadequate to meet the demands of the travelling public as well as those of the industrial and agricultural sectors. The continuous improvement in bridge systems is an important indication of the current scientific and technological revolution which has a direct bearing on the progress of productive forces.

Bridges play a vital role in shaping the history of a country as the existence or otherwise of these bridges very much affect the movement of troops during the hostilities and consequently these bridge points are required to defend ourselves from the onslaught of the invaders. No road system is considered complete in itself without the provision of such cross drainage works in the form of bridges, so that there is no hindrance to the free flow of traffic, especially during the rains.

Many types of bridges have been constructed from the times of olden days ranging from the timber bridges to modern steel and pre-stressed concrete bridges. The modern bridges are usually constructed of steel, being durable and easy to fabricate. The high tensile steel used has minimum tensile strength of 55 kg/mm. The bolts and nuts used in the bridge are of mild steel having tensile strength of not less than 44 kg/mm. The type of steel bridge to be used depends on the span.

Types of Bridges

- Cable stayed bridge
 - Wooden bridge
 - Floating bridge
 - Moveable bridge
- Suspension bridge
- Cantilever bridge
- Truss bridge
- Arch bridge
- Composite bridge.

Cable stayed bridges

Cable stayed bridges are usually constructed over gorges in hilly countries where the water flow in the stream below is very fast. Cable stayed bridges are constructed with boulders where piers cannot be easily constructed. These bridges have a span of 150 metres and are usually meant for pedestrian traffic. The deck is supported by long cables carried over tall towers provided at their ends. Figure 1.6 shows a general view of a cable stayed bridge.

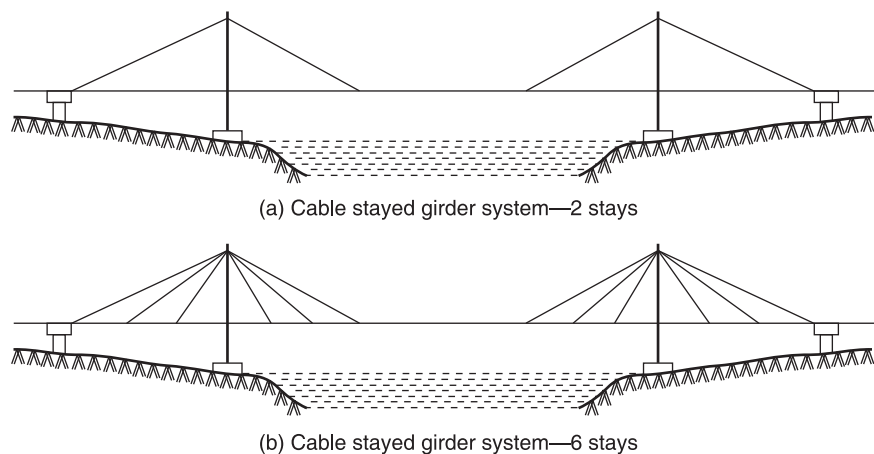

Figure 1.6 A general view of cable stayed bridges.

Timber bridges

Timber bridges (Figure 1.7) are temporary constructions to cross streams and obstacles, specially built in forest areas where timber is available in abundance, and also where speedy erection is required as in times of war. When the materials for constructing permanent bridges are not available or the same are available at long distances entailing huge cost of construction, these wooden bridges are suitable and cheaper.

Timber bridges have a life-span of about 15 years and may require replacement thereafter. They are likely to be destroyed by fire and fungus growth if not properly maintained. They are suitable for small spans of 5 metres or so. The state Jammu and Kashmir has several such wooden bridges constructed many years ago. Bridges constructed purely of timber may have either timber arch construction or be of strutted beam type. The points to be borne in mind while deciding the construction of timber bridges are:

- Duration of time for which the bridge is required
- Amount of load required to be carried
- Quality of timber available
- Method of erection.

Floating bridges

Floating bridges, also known as pontoon bridges, are temporary structures constructed over rivers in times of emergency during wars where the time is of fundamental importance. The advantage of these floating bridges is that they can be erected very quickly as the component parts of the bridge are of pre-fabricated types as per the dimensions approved by the Indian Road Congress and hence

can also be dismantled in a very short time. The materials used for the parts are strong, durable and non-corrosive. A typical view of a floating bridge is shown in Figure 1.8.

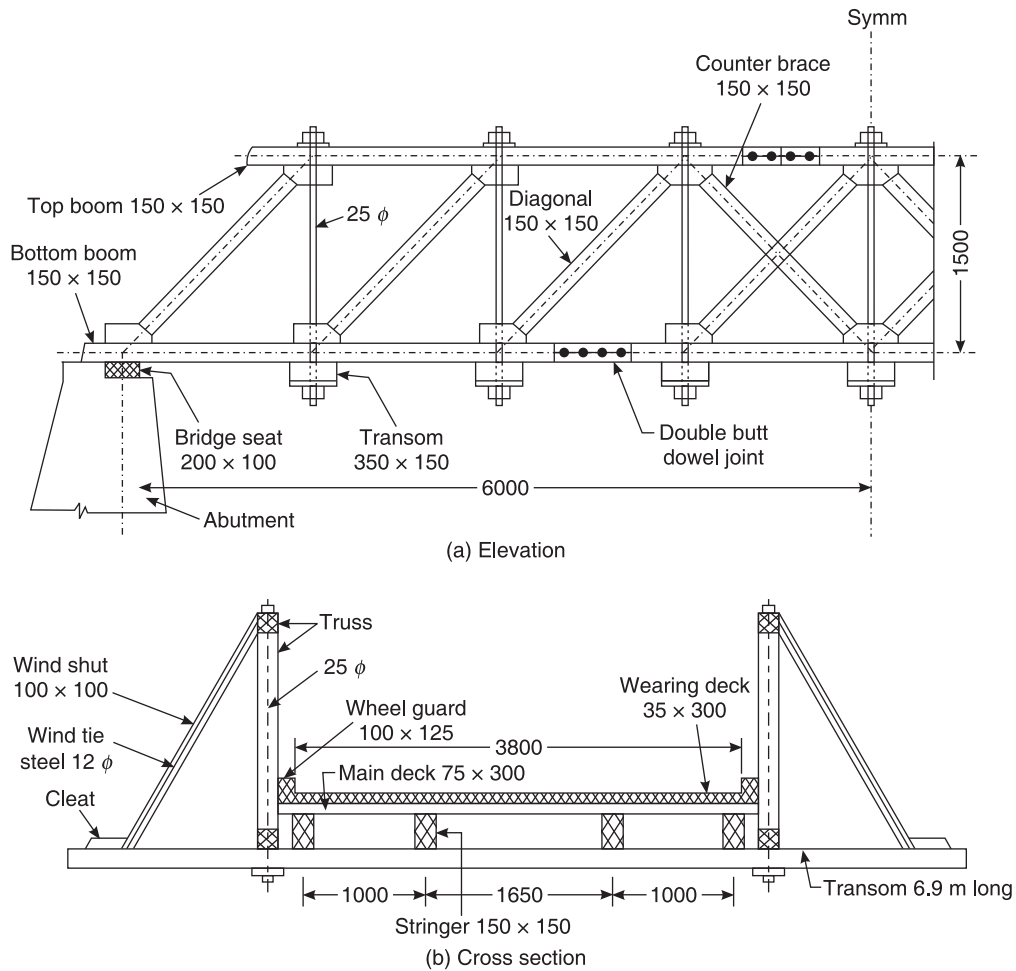

Figure 1.7 Timber bridges.

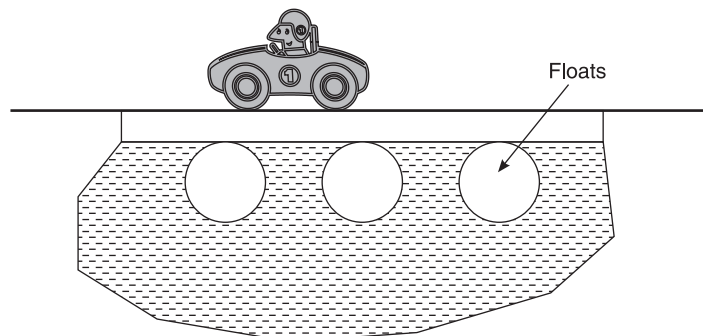

Figure 1.8 Floating bridge.

Movable bridges

As stated before, bridges are also classified according to the method of giving clearance to navigation. Under that classification, movable bridges are of the following four types, namely:

- Swing bridges
- Bascule bridges
- Lift bridges
- Transporter bridges

Swing bridges: In case of swing bridges there is a disc bearing placed over the central pier on which two pans of continuous trusses are provided (Figure 1.9). By an arrangement of rotating gear, the whole truss rotates horizontally through 90° when its axis becomes parallel to the direction of flow of water and at that position pedestrians or other vehicles cannot move.

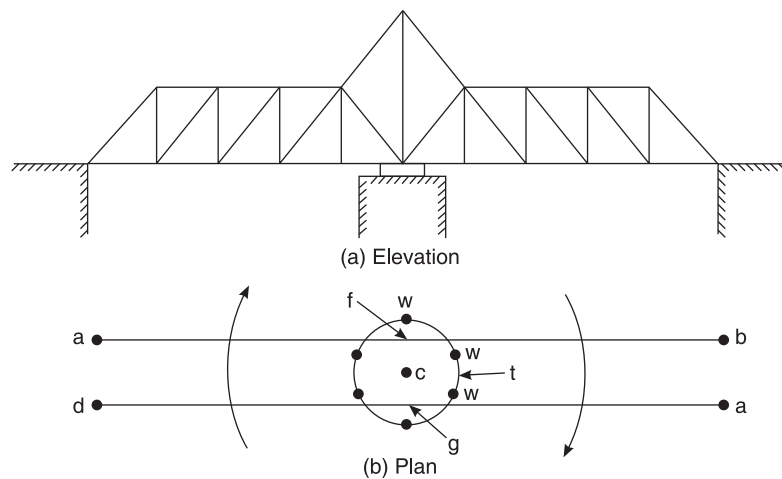

Figure 1.9 A swing bridge.

Bascule bridges: A rough idea of the working of a bascule bridge can be had from the common toll tax barrier arrangement in India where a full span pole can be lowered and raised with the help of a counterweight placed at one end. In a bascule bridge, instead of the pole, there is provided a hinged truss which can be raised or lowered in a vertical plane with the help of a counterweight or rack and pinion arrangement or by cables. A general view of single and double bascule bridges is shown in Figure 1.10.

Lift bridges: For wide channels the bascule bridges are not economical. In such cases the vertical lift bridges are recommended to give clearance to navigation. A vertical lift consists of a roadway truss which is lifted up by means of cables passing over pulleys attached to each of the two tall towers erected at either ends. These cables are connected to counterweights at the other end. A general view of a vertical bridge is shown in Figure 1.11.

Transporter bridges: In case of transporter bridges, a moving cage is suspended from an overhead truss with the help of a cable or wire ropes. The overhead truss rests on two towers and it contains rails for the cage to roll. The cage is loaded with persons or goods and it is then allowed

to move from one end to the other end of river. This type of bridge is used within a harbour area to provide an arrangement for shifting of men and materials across a channel. A general view of a transporter bridge is shown in Figure 1.12.

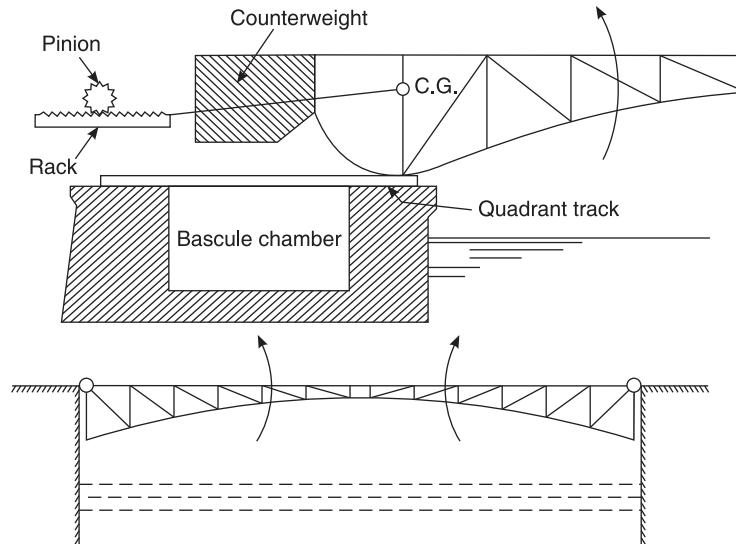

Figure 1.10 Single and double bascule bridges.

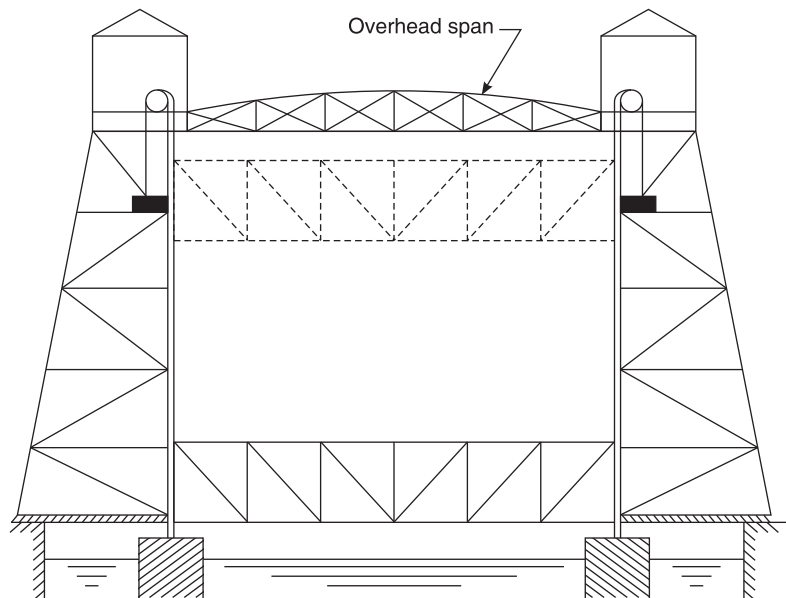

Figure 1.11 A general view of a vertical bridge.

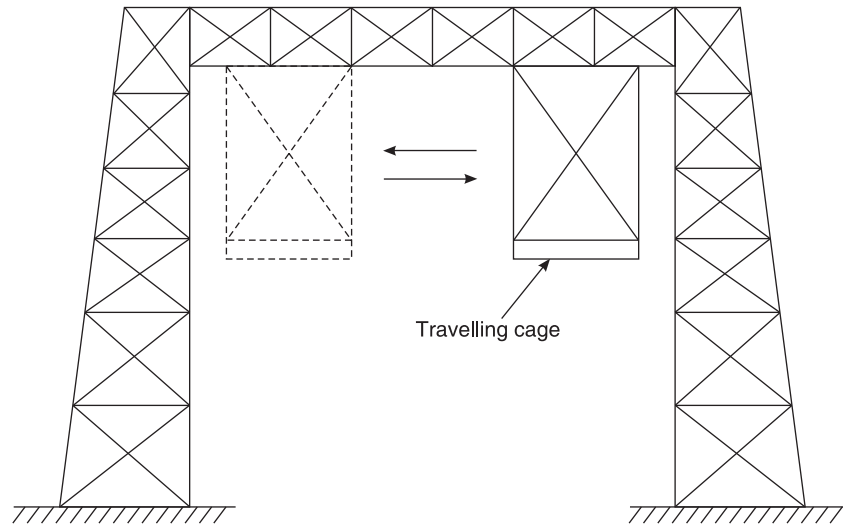

Figure 1.12 A general view of a transporter bridge.

Suspension bridges

Suspension bridges are long-span bridges involving creative works and great skill on the part of the bridge engineer. For the stability of such long-span bridges of 600 m and above, considerations for the control of aerodynamic movement, the local angle changes in the deck and vertical oscillations caused by serve winds are of vital importance, failing which a failure of the bridge may result. Figure 1.13 gives the idea of this type of bridge.

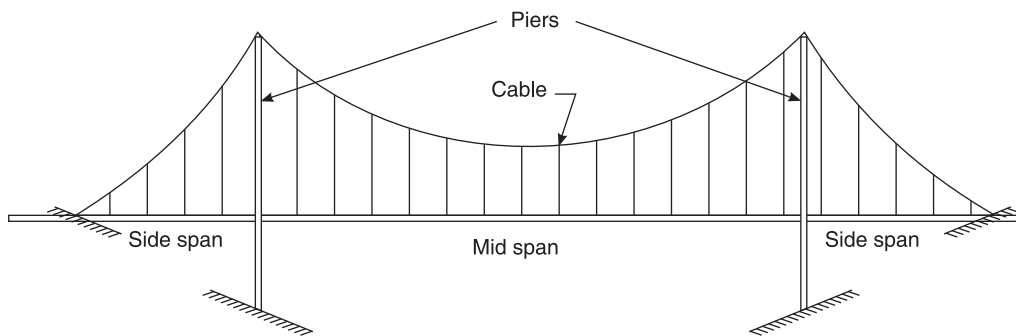

Figure 1.13 A simple suspension bridge.

Cantilever bridges

Cantilever bridges, due to their heavier weights and labour involved in construction compared to the cable stayed bridges for the same spans, are no longer popular. It is so called as in a single span there are cantilever arms from each pier to the ends where the freely supported suspended span rests. Then there are anchor arms at either end between the abutment and the pier. Some views of cantilever bridges are shown in Figure 1.14.

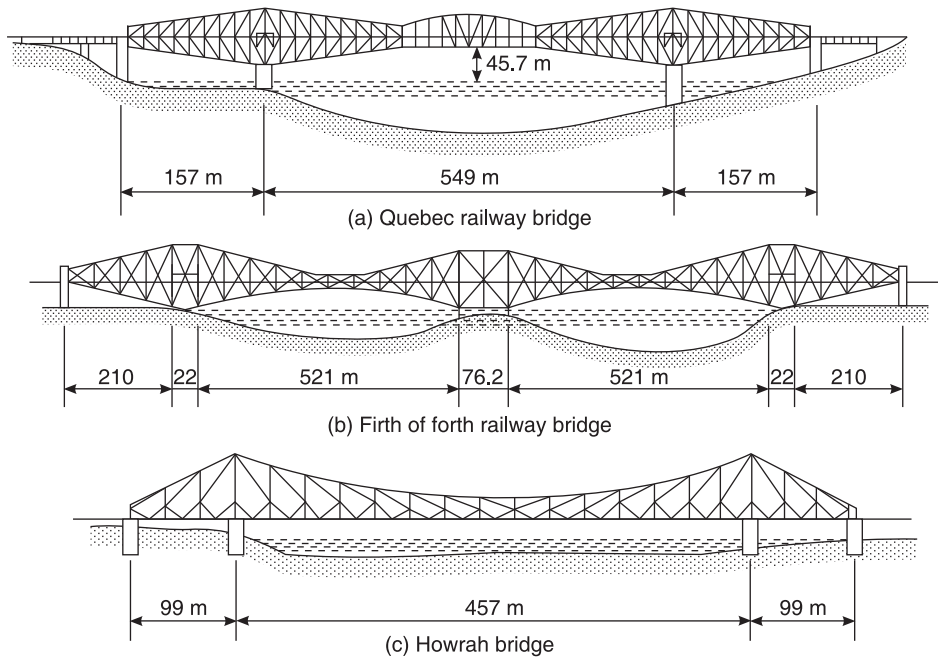

Figure 1.14 Views of cantilever bridges.

Truss bridges

For rail-road or long railway bridges of spans 100 to 200 meters, truss bridges (Figure 1.15) are found suitable and expedient due to relative lightness of its component parts. There are various types of truss bridges like the Warren truss bridge, Pratt truss and N-truss, but the most common form is the Warren truss type.

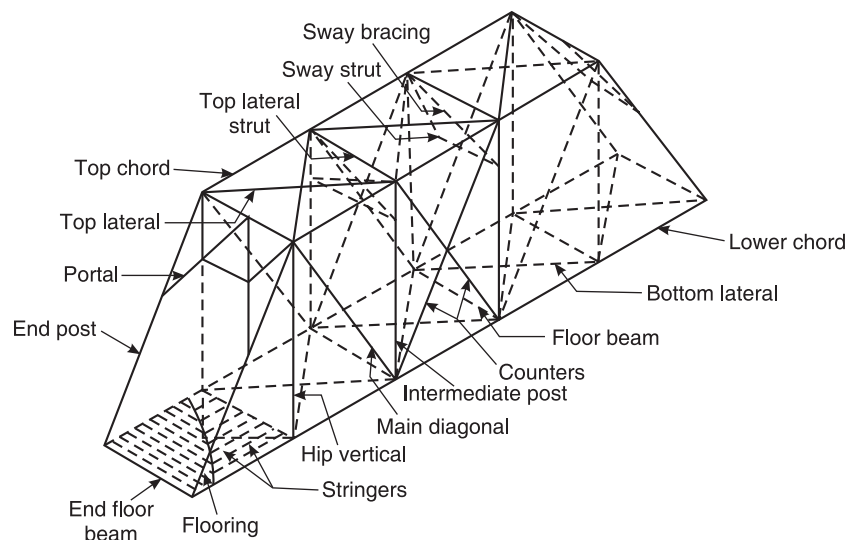

Figure 1.15 Truss bridge.

Arch bridges

In case of arch bridges the abutments must be strong enough to carry the thrust exerted by the ribs. In such cases heavy expensive abutments will be required, unless there is a gorge with rocky banks which might be strong enough to bear the load exerted by the ribs; and it is in such situations where arch bridges are most recommended. Arch bridges may be made of masonry or steel. Masonry arch bridges are not recommended for spans exceeding 6 metres, especially in seismic zones. For long spans, steel arch bridges are generally used. The arch bridges may be rigid, of two hinge or three hinge type. See Figure 1.16.

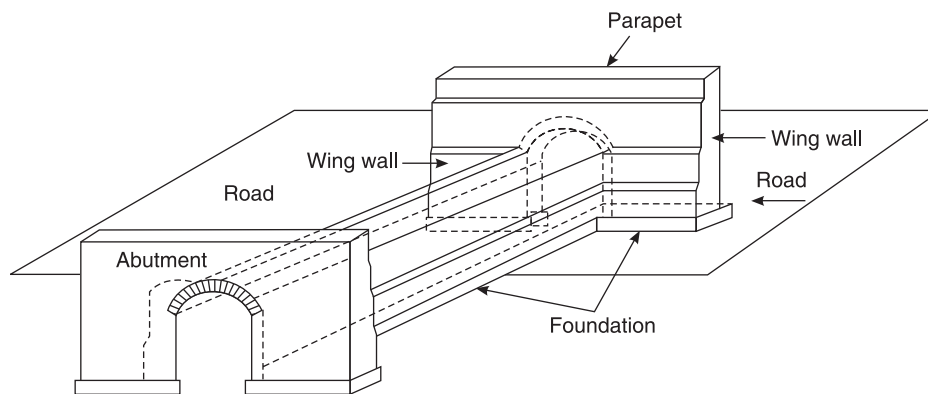

Figure 1.16 An arch culvert.

EXERCISE PROBLEMS

1. Briefly explain the different fields of civil engineering or scope of civil engineering.
2. What is infrastructure? Explain the impact of infrastructural development on a country.
3. Briefly explain the role of civil engineers in the infrastructural development.
4. Explain the classification of roads.
5. Write a brief note on classification of bridges.
6. What is dam? Briefly describe the different types of dams.

AN OVERVIEW

Mechanics is the physical science concerned with the study of response of bodies under the application of forces. Engineering mechanics is the application of mechanics to the solution of engineering problems. It is broadly classified into three types:

- (a) Mechanics of rigid bodies
- (b) Mechanics of deformable bodies
- (c) Mechanics of fluids.

Mechanics of Rigid Bodies

It is the branch of science which deals with the study of bodies that do not undergo any deformation under the application of forces. It can further be classified into Statics and Dynamics.

Statics

It is the branch of mechanics which deals with the study of the behaviour of bodies or particles in the state of rest.

Dynamics

It is the branch of mechanics which deals with the study of the behaviour of bodies or particles in the state of motion. Dynamics is further divided into two types:

- (a) *Kinematics*: The forces causing the motion are not considered.
- (b) *Kinetics*: The forces causing the motion are mainly considered.

Mechanics of Deformable Bodies

It is the branch of science which deals with the study of bodies that undergo deformation under the application of forces. It is classified into:

- (a) Strength of materials
- (b) Theory of plasticity
- (c) Theory of elasticity.

Mechanics of Fluids

It is the branch of science which deals with the study of fluids. Fluids can be classified into:

- (a) Compressible fluids
- (b) Incompressible fluids.

FORCE AND FORCE SYSTEM

Technical Terms Used in Engineering Mechanics

Particle: A body of infinitely small volume whose mass can be neglected, is called a particle.

Body: The assemblage of a number of particles is known as a body.

Rigid body: A rigid body is one in which the positions of the constituent particles do not change under the application of external forces, such as the position of particles 1 and 2 in Figure 2.1.

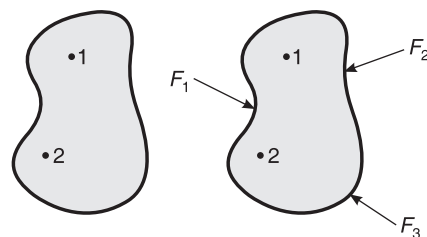

Figure 2.1 Rigid body.

Deformable body: A deformable body is one in which the positions of constituent particles change under the application of external forces, such as the positions of particles 1 and 2 in Figure 2.2.

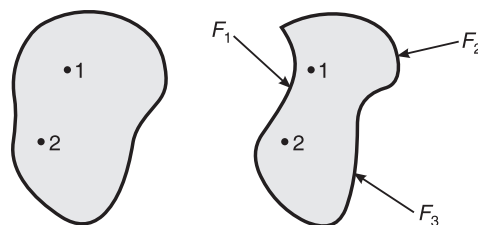

Figure 2.2 Deformable body.

Mass (m): The total amount of matter present in a body is known as its mass. The unit of mass is the kilogram, abbreviated kg.

Weight: A body is attracted towards the earth due to gravitation. This causes an acceleration directed towards the centre of earth. It is called acceleration due to gravity and is denoted by g . The resulting force is equal to the weight of body.

$$\begin{aligned}\text{Weight} &= \text{mass} \times \text{acceleration due to gravity} \\ W &= mg, \text{ in newton, where } g = 9.81 \text{ m/s}^2\end{aligned}$$

Scalar quantity: A physical quantity which has only magnitude, is called scalar quantity. For example, time, mass, density, volume, distance, and so forth.

Vector quantity: A physical quantity which has a direction in addition to magnitude, is known as vector quantity. For example, force, displacement, velocity, acceleration, and so forth.

Continuum: A continuous distribution of molecules in a body without intermolecular space is called the continuum.

Newton's Laws of Motion

Newton's First law: This law states that 'every body continues in its state of rest or of uniform motion along a straight line, so long as it is under the influence of a balanced force system'.

Newton's Second law: This law states that 'the rate of change momentum of a body is directly proportional to the impressed force and it takes place in the direction of the force acting on it'.

Newton's Third law: This law states that 'action and reaction are equal in magnitude but opposite in direction'.

Force: It is the external agency which tends to change the state of a body or a particle. When a force is applied to a body which is at rest, the body may remain in the state of rest or it may move with some velocity. The SI unit of force is newton.

Elements of a Force or Characteristics of a Force

A force can be identified by its four characteristics:

- (i) **Magnitude:** The length of the vector represents the magnitude of force, as shown in Figure 2.3.



Figure 2.3 Magnitude of force vector.

- (ii) **Direction:** The direction of a force can be represented by an arrowhead.
 (iii) **Line of action:** It is the line along which the force acts.
 (iv) **Point of application:** It is the point at which the force acts.

Point force

A force which is acting at a fixed point is known as the point force. Let us consider a man climbing a ladder. The weight of the man is not actually concentrated at a fixed point but for the purpose of analysis it is assumed to be concentrated at a particular point.

24 ELEMENTS OF CIVIL ENGINEERING AND ENGINEERING MECHANICS

Force system

If two or more forces are acting on a body or a particle, then it is said to be a force system, such as that shown in Figure 2.4.

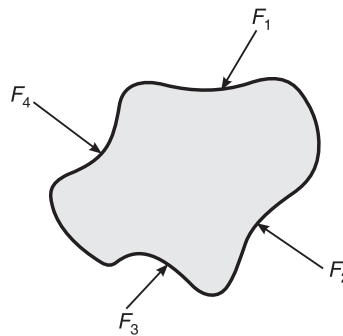

Figure 2.4 A force system.

Types of Force System

The types of force system are:

1. Coplanar force system
2. Non-coplanar force system
3. Collinear force system.

Coplanar force system

If two or more forces are acting in a single plane, then it is said to be a coplanar force system. The types of coplanar force system are:

- (i) Coplanar concurrent force system
- (ii) Coplanar non-concurrent force system
- (iii) Coplanar parallel force system.

If two or more forces are acting in a single plane and their lines of action pass through a single point, then it is said to be a **coplanar concurrent force system**. See Figure 2.5.

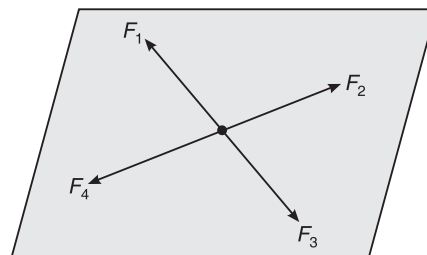

Figure 2.5 Coplanar concurrent force system.

If two or more forces are acting in a single plane and their lines of action do not meet at a common point, then the forces constitute a **coplanar non-concurrent force system**. See Figure 2.6.

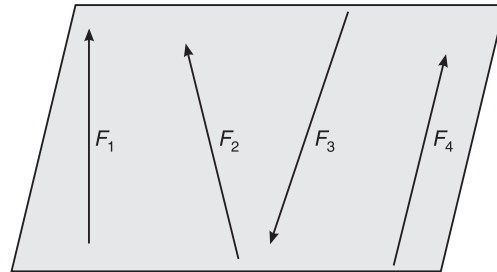

Figure 2.6 Coplanar non-concurrent force system.

If two or more forces are acting in a single plane with their lines of action parallel to one another, then it is said to be a **coplanar parallel force system**.

The coplanar parallel force system is of two types:

- (i) **Like parallel force system:** All the forces act parallel to one another and are in the same direction, as shown in Figure 2.7.

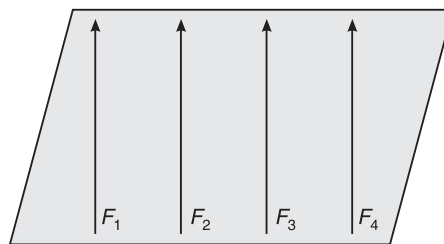

Figure 2.7 Like parallel force system.

- (ii) **Unlike parallel force system:** The forces act parallel to another, but some of the forces have their line of action in opposite directions, as shown in Figure 2.8.

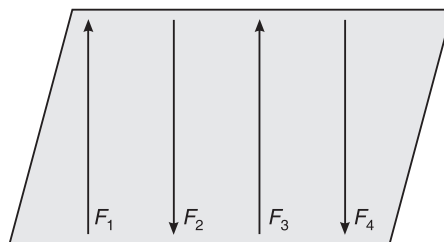

Figure 2.8 Unlike parallel force system.

Non-coplanar force system

If two or more forces are acting in different planes, the forces constitute a non-coplanar force system. Such a system of forces can be

- (i) Non-coplanar concurrent force system
- (ii) Non-coplanar non-concurrent force system
- (iii) Non-coplanar parallel force system.

26 ELEMENTS OF CIVIL ENGINEERING AND ENGINEERING MECHANICS

If a system has two or more forces acting on different planes but pass through the same point, then it is said to be a **non-coplanar concurrent force system**. See Figure 2.9.

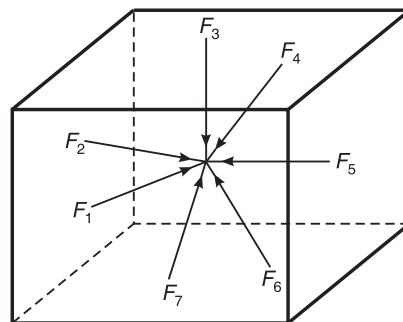

Figure 2.9 Non-coplanar concurrent force system.

If two or more forces are acting on different planes but do not pass through the same point, they constitute a **non-coplanar non-concurrent force system**. See Figure 2.10.

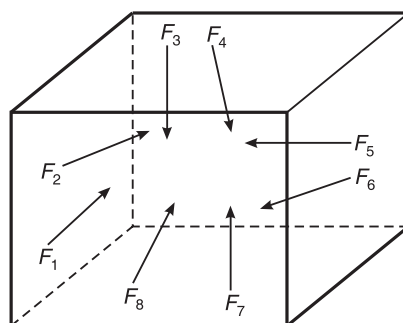

Figure 2.10 Non-coplanar non-concurrent force system.

If two or more forces are acting in different planes and are parallel to one another, the system is said to be a **non-coplanar parallel force system**. See Figure 2.11.

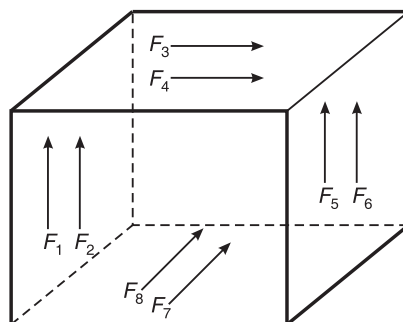

Figure 2.11 Non-coplanar parallel force system.

Collinear force system

If the lines of action of two or more forces coincide with one another, it is called a collinear force system as shown in Figure 2.12.

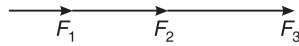

Figure 2.12 Collinear force system.

Non-collinear force system

If the lines of action of the forces do not coincide with one another, it is called a non-collinear force system as shown in Figure 2.13.

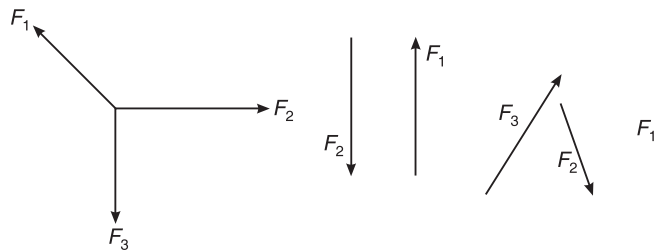

Figure 2.13 Non-collinear force system.

Principle of Transmissibility of Forces

This principle states that a force can be transmitted from one point to another point along the same line of action such that the effect produced by the force on a body remains unchanged. Let us consider a rigid body subjected to a force of F at point O as shown in Figure 2.14. According to the principle of transmissibility, the force F can be transmitted to a new point O' along the same line of action such that the net effect remains unchanged.

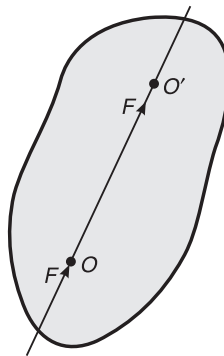

Figure 2.14 Transmissibility of force F from point O to O' .

Principle of Superposition of Forces

This principle states that the net effect of a system of forces on a body is same as that of the combined effect of individual forces on the body.

Principle of Physical Independence of Forces

This principle states that ‘the action of a force on a body is not affected by the action of any other force on the body’.

Resolution of a Force

The process of splitting of a force into its two rectangular components (horizontal and vertical) is known as resolution of the force, as shown in Figure 2.15. In this figure, F is the force which makes an angle θ with the horizontal axis, and has been resolved into two components, namely F_x and F_y , along the x -axis and y -axis respectively.

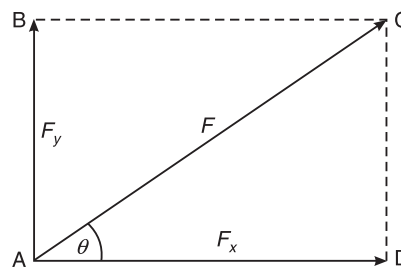

Figure 2.15 Resolution of a force.

In $\triangle CAD$,

$$\cos \theta = \frac{F_x}{F} \Rightarrow F_x = F \cos \theta$$

$$\sin \theta = \frac{F_y}{F} \Rightarrow F_y = F \sin \theta$$

If, on the other hand, θ is the angle made by the force F with the vertical axis, then

$$F_y = F \cos \theta; \quad F_x = F \sin \theta$$

Note: If the force F makes an angle of θ with the horizontal, the horizontal component of the force is $F \cos \theta$.

Composition of Forces

It is the process of combining a number of forces into a single force such that the net effect produced by the single force is equal to the algebraic sum of the effects produced by the individual forces. The single force in this case is called the **resultant force** which produces the same effect on the body as that produced by the individual forces acting together. For example, in Figure 2.16,

ΣF_x = algebraic sum of the components of the forces along the x -axis

i.e. $\Sigma F_x = F_4 + F_1 \cos \theta_1 - F_3 \sin \theta_2$

and ΣF_y = algebraic sum of the components of the forces along the y -axis

i.e. $\Sigma F_y = -F_2 - F_1 \sin \theta_1 - F_3 \cos \theta_2$

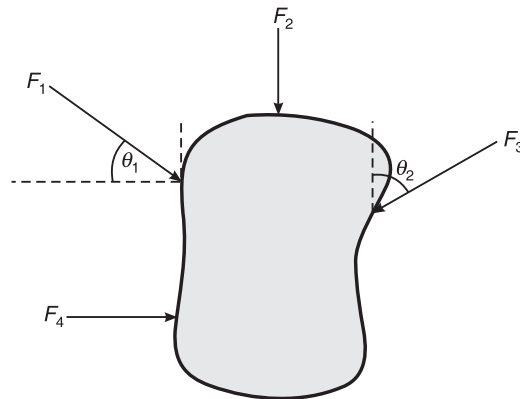

Figure 2.16 A body acted upon by a number of forces.

Note: The positive and negative convention of forces used in the resolution of forces in Figure 2.16 is as that shown in Figure 2.17.

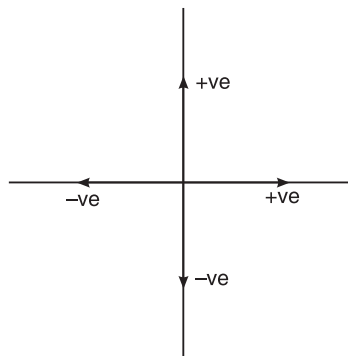

Figure 2.17 Positive and negative convention of forces.

\therefore The magnitude of the resultant,

$$R = \sqrt{\Sigma F_x^2 + \Sigma F_y^2}$$

and the direction of the resultant,

$$\theta = \tan^{-1} \left(\frac{\Sigma F_y}{\Sigma F_x} \right)$$

Methods of finding the resultant

The resultant of a system of coplanar concurrent forces can be determined by the following methods.

Parallelogram law: If two forces are acting simultaneously on a particle and away from the particle, with the two adjacent sides of the parallelogram representing both the magnitude and direction of forces, the magnitude and direction of the resultant can be represented by the diagonal of the parallelogram starting from the common point of the two forces. See Figure 2.18.

30 ELEMENTS OF CIVIL ENGINEERING AND ENGINEERING MECHANICS

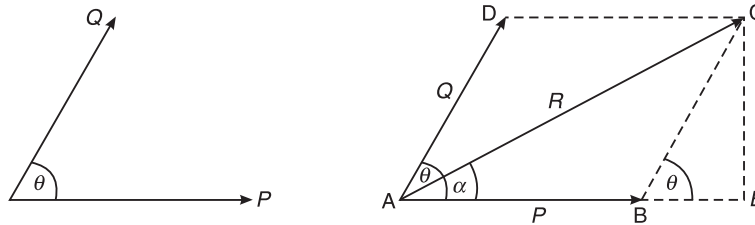

Figure 2.18 Parallelogram law of forces.

Let P and Q be the two forces, represented by the sides AB and AD of the parallelogram, the resultant can then be represented by AC as shown below:

To find the magnitude R of the resultant, consider the ΔCAE , where

$$\begin{aligned} AC^2 &= AE^2 + CE^2 \\ &= (AB + BE)^2 + (CE)^2 \end{aligned}$$

Consider the ΔCBE , where

$$CE = Q \sin \theta$$

$$BE = Q \cos \theta$$

$$\therefore AC^2 = AB^2 + 2AB \cdot BE + BE^2 + CE^2$$

$$\begin{aligned} \text{or } R^2 &= P^2 + 2 \cdot P \cdot Q \cos \theta + Q^2 \cos^2 \theta + Q^2 \sin^2 \theta \\ &= P^2 + Q^2 + 2PQ \cos \theta \end{aligned}$$

$$\text{i.e. } R = \sqrt{P^2 + Q^2 + 2PQ \cos \theta}$$

To find the direction α of the resultant, consider the ΔCAE , where

$$\begin{aligned} \tan \alpha &= \frac{CE}{AB + BE} \\ &= \frac{Q \sin \theta}{P + Q \cos \theta} \end{aligned}$$

$$\therefore \alpha = \tan^{-1} \left(\frac{Q \sin \theta}{P + Q \cos \theta} \right)$$

Triangle law: If two forces acting simultaneously on a particle can be represented both in magnitude and direction by the two sides of a triangle taken in order, then the magnitude and direction of the resultant can be represented by the third side of a triangle, taken in opposite order. This is illustrated in Figure 2.19.

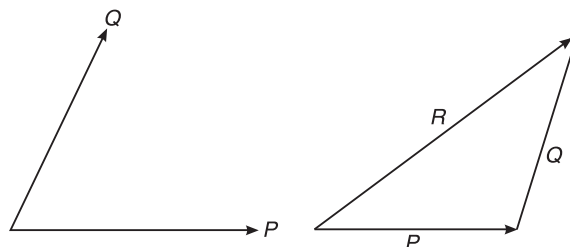

Figure 2.19 Triangle law of forces.

Polygon law: If a number of forces acting on a particle can be represented in both magnitude and direction by the sides of the polygon taken in order, then the resultant can be represented in magnitude and direction by the closing side of the polygon taken in the opposite order. This is illustrated in Figure 2.20.

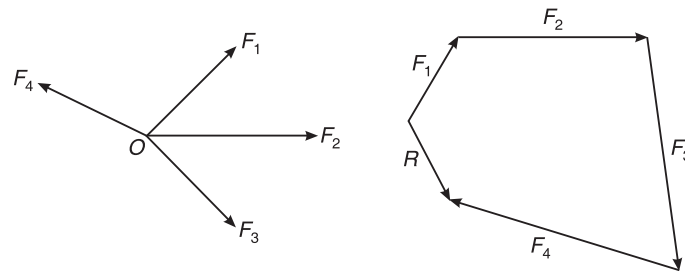

Figure 2.20 Polygon law of forces.

Moment of a Force

The turning effect produced by a force on a body is known as the moment of the force. The magnitude of the moment is given by the product of the magnitude of the force and the perpendicular distance between the line of action of the force and the point or axis of rotation. This is shown in Figure 2.21(a).

Types of moments

- (i) If the tendency of a force is to rotate the body in the clockwise direction, it is said to be a clockwise moment and is taken positive, as shown in Figure 2.21(b).
- (ii) If the tendency of a force is to rotate the body in the anticlockwise direction, it is said to be anticlockwise moment and is taken negative as shown in Figure 2.21(c).

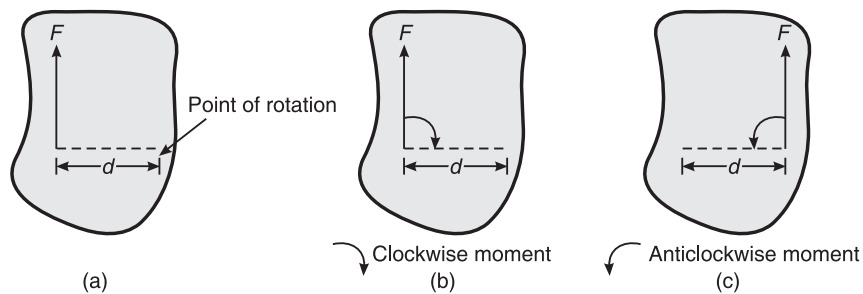

Figure 2.21 Moment of a force.

Varignon's theorem of moments

This is also known as the principle of moments. The theorem states that “the algebraic sum of the moments of individual forces of a force system about a point is equal to the moment of their resultant about the same point. Let R be the resultant of forces P_1 and P_2 and B be the moment centre. Let d , d_1 and d_2 be the moment arms of forces R , P_1 and P_2 , respectively, from the moment centre B (Figure 2.22).

We have to prove that

$$Rd = P_1d_1 + P_2d_2$$

32 ELEMENTS OF CIVIL ENGINEERING AND ENGINEERING MECHANICS

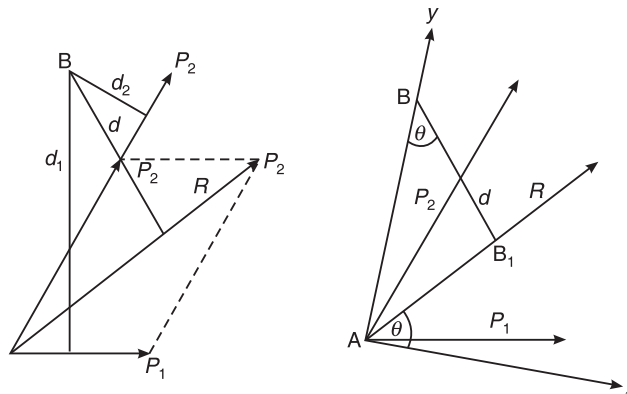

Figure 2.22 Theorem of moments.

Proof: Join AB and consider it as the y -axis and draw the x -axis at right angles to it at A. Let θ be the angle made by R with the x -axis and note that the same angle is formed with the y -axis by the perpendicular to R from B and note this point as B_1 .

We know that,

$$\begin{aligned} Rd &= R \times AB \cos \theta \\ &= AB \times R \cos \theta \end{aligned}$$

$$\text{or} \quad Rd = AB \times R_x \quad \text{(i)}$$

where R_x is the component of R in the x -direction. Similarly, if P_{1x} and P_{2x} are the components of P_1 and P_2 in the x -direction, respectively, then,

$$P_1 d_1 = AB \times P_{1x} \quad \text{(ii)}$$

$$\text{and} \quad P_2 d_2 = AB \times P_{2x} \quad \text{(iii)}$$

Adding equations (ii) and (iii), we get

$$P_1 d_1 + P_2 d_2 = AB(P_{1x} + P_{2x})$$

$$\text{or} \quad P_1 d_1 + P_2 d_2 = AB \times R_x \quad \text{(iv)}$$

Since the sum of x -components of the individual forces is equal to the x -component of the resultant R , from equations (i) and (iv), we can conclude that

$$Rd = P_1 d_1 + P_2 d_2 \quad \square$$

Couple

Two equal, opposite and parallel forces constitute a couple as shown in Figure 2.23.

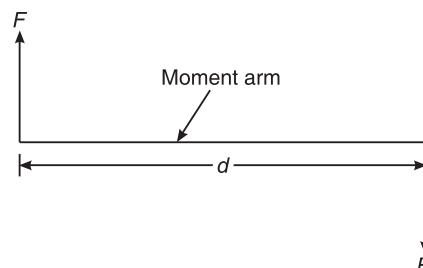

Figure 2.23 A couple.

Properties of couple

- (i) Two equal and opposite parallel forces are required to form a couple.
- (ii) The magnitude of the moment of the couple = product of the magnitude of one of the forces and moment arm (perpendicular distance between the two forces).
- (iii) Resultant of the forces of the couple is zero.

Types of couple

- (i) Clockwise couple.
- (ii) Anticlockwise couple.

EXERCISE PROBLEMS

1. Define the following terms:
 - (a) Statics
 - (b) Dynamics
2. What are the two divisions of dynamics?
3. What are the four characteristics of a force?
4. What are the three types of force systems?
5. Define the principle of superposition of forces.
6. What are the various methods of finding the resultant of a system of coplanar concurrent forces?
7. Define the moment of a force.
8. Define Varignon's theorem of moments.
9. What is a couple? What are two types of couple?

COPLANAR CONCURRENT FORCE SYSTEM

DEFINITION

If two or more forces are acting in a single plane and passing through a single point, such a force system is known as coplanar concurrent force system.

In a coplanar concurrent force system, we can calculate the magnitude and direction of the resultant. The position, however, cannot be determined because all forces are meeting at a common point. Thus,

The magnitude of resultant,

$$R = \sqrt{\Sigma F_x^2 + \Sigma F_y^2}$$

Direction of resultant,

$$\theta = \tan^{-1} \left(\frac{\Sigma F_y}{\Sigma F_x} \right)$$

The steps to solve problems in the coplanar concurrent force system are, therefore, as follows:

1. Calculate the algebraic sum of all the forces acting in the x -direction (i.e. ΣF_x) and also in the y -direction (i.e. ΣF_y).
2. Determine the magnitude of the resultant using the formula, $R = \sqrt{\Sigma F_x^2 + \Sigma F_y^2}$.
3. Determine the direction of the resultant using the formula, $\theta = \tan^{-1} \left(\frac{\Sigma F_y}{\Sigma F_x} \right)$.

PROBLEMS ON COPLANAR CONCURRENT FORCE SYSTEM

Example 3.1 A force of 200 N is acting at a point making an angle of 40° with the horizontal (Figure 3.1). Determine the components of this force along the x and y directions. *VTU (Jan 2007)*

Solution Component along the x -direction,

$$F_x = F \cos \theta \\ = 200 \times \cos 40^\circ = 153.208 \text{ N}$$

Component along the y -direction,

$$F_y = F \sin \theta \\ = 200 \times \sin 40^\circ = 128.557 \text{ N}$$

Ans.

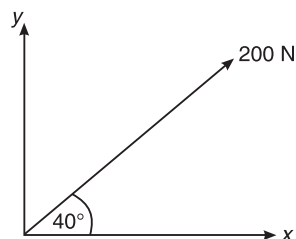

Figure 3.1 Example 3.1.

Example 3.2 Five coplanar forces are acting at a point as shown in Figure 3.2. Determine the resultant in magnitude and direction.

Solution Here:

$$\Sigma F_x = -200 \sin 30^\circ - 275 \cos 6^\circ - 250 \sin 20^\circ + 100 \cos 45^\circ + 200 \sin 30^\circ = -288.287 \text{ N}$$

$$\Sigma F_y = 200 \cos 30^\circ - 275 \sin 6^\circ - 250 \cos 20^\circ + 100 \sin 45^\circ + 200 \cos 30^\circ = 153.452 \text{ N}$$

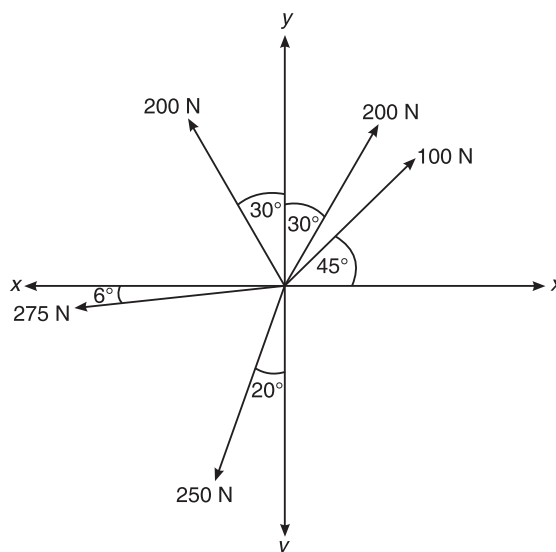

Figure 3.2 Example 3.2.

$$\therefore R = \sqrt{(-288.287)^2 + (153.452)^2} = 326.584 \text{ N}$$

Ans.

Also,

$$\theta = \tan^{-1} \left(\frac{\Sigma F_y}{\Sigma F_x} \right)$$

36 ELEMENTS OF CIVIL ENGINEERING AND ENGINEERING MECHANICS

$$\text{or} \quad \theta = \tan^{-1} \left(\frac{153.452}{-288.287} \right)$$

$$\therefore \quad \theta = 28.02^\circ$$

Ans.**Example 3.3** Find the resultant of the coplanar concurrent force system shown in Figure 3.3.

VTU(March 2005)

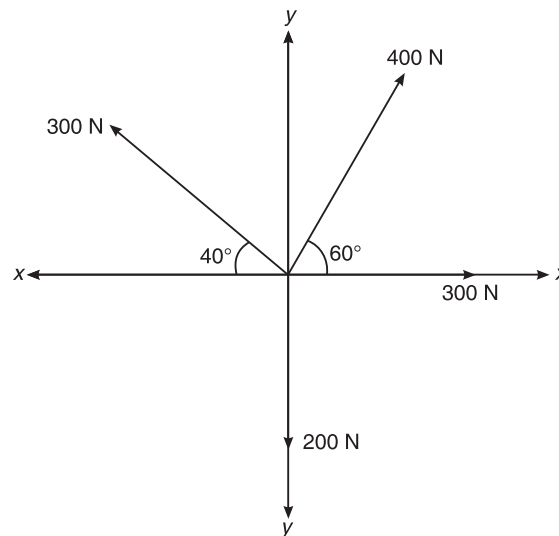
**Figure 3.3** Example 3.3.**Solution** Here:

$$\begin{aligned} \Sigma F_x &= 300 \cos 0^\circ + 400 \cos 60^\circ - 300 \cos 40^\circ \\ &= 300 + 200 - 229.8133 = 270.187 \text{ N} \end{aligned}$$

$$\begin{aligned} \Sigma F_y &= 400 \sin 60^\circ + 300 \sin 40^\circ - 200 \\ &= 346.4102 + 192.8363 - 200 = 339.246 \text{ N} \end{aligned}$$

$$\therefore \quad R = \sqrt{(270.187)^2 + (339.246)^2} = 433.692 \text{ N}$$

Ans.

$$\text{Also,} \quad \theta = \tan^{-1} \left(\frac{339.246}{270.187} \right)$$

$$\therefore \quad \theta = \tan^{-1}(1.256) = 51.47^\circ$$

Ans.**Example 3.4** Find the magnitude and direction of the resultant of the coplanar force system shown in Figure 3.4.

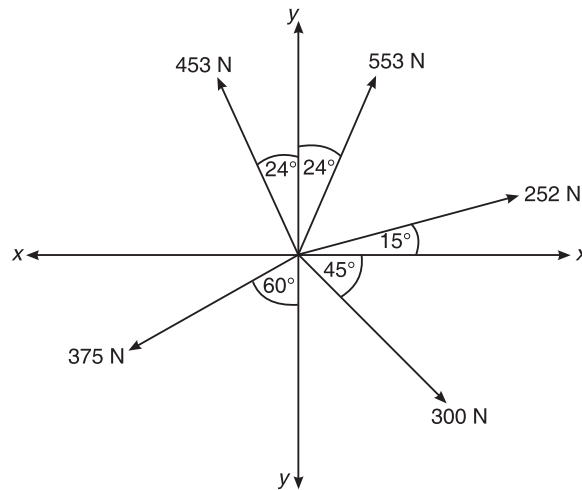

Figure 3.4 Example 3.4.

Solution Here:

$$\begin{aligned}\Sigma F_x &= 300 \cos 45^\circ - 453 \sin 24^\circ + 252 \cos 15^\circ + 553 \sin 24^\circ - 375 \sin 60^\circ \\ &= 171.459 \text{ N}\end{aligned}$$

$$\begin{aligned}\Sigma F_y &= -300 \sin 45^\circ + 453 \cos 24^\circ + 252 \sin 15^\circ + 553 \cos 24^\circ - 375 \cos 60^\circ \\ &= 584.617 \text{ N}\end{aligned}$$

$$\begin{aligned}\therefore R &= \sqrt{(171.459)^2 + (584.617)^2} \\ &= 609.241 \text{ N}\end{aligned}$$

Ans.

Also, $\theta = \tan^{-1}\left(\frac{584.617}{171.459}\right)$

$$\therefore \theta = 73.65^\circ$$

Ans.

Example 3.5 Find the resultant of the force system shown in Figure 3.5.

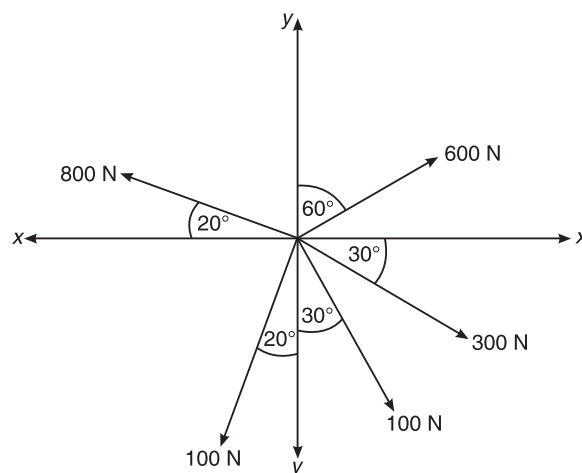

Figure 3.5 Example 3.5.

38 ELEMENTS OF CIVIL ENGINEERING AND ENGINEERING MECHANICS

Solution Here:

$$\Sigma F_x = 600 \sin 60^\circ + 300 \cos 30^\circ + 100 \sin 30^\circ - 100 \sin 20^\circ - 800 \cos 20^\circ = 43.467 \text{ N}$$

$$\Sigma F_y = 600 \cos 60^\circ - 300 \sin 30^\circ - 100 \cos 30^\circ + 100 \cos 20^\circ + 800 \sin 20^\circ = 243.044 \text{ N}$$

$$\begin{aligned} \therefore R &= \sqrt{\Sigma F_x^2 + \Sigma F_y^2} \\ &= \sqrt{(43.467)^2 + (243.044)^2} \end{aligned}$$

$$\text{or } R = 246.900 \text{ N} \quad \text{Ans.}$$

$$\text{Also, } \theta = \tan^{-1} \left(\frac{\Sigma F_y}{\Sigma F_x} \right) = \tan^{-1} \left(\frac{243.044}{43.467} \right)$$

$$\therefore \theta = 79.86^\circ. \quad \text{Ans.}$$

Example 3.6 Four coplanar forces acting at a point are shown in Figure 3.6. One of the forces is unknown and its magnitude is shown by P . The resultant has a magnitude of 500 N and is acting along the x -axis. Determine the unknown force P and its inclination with the x -axis.

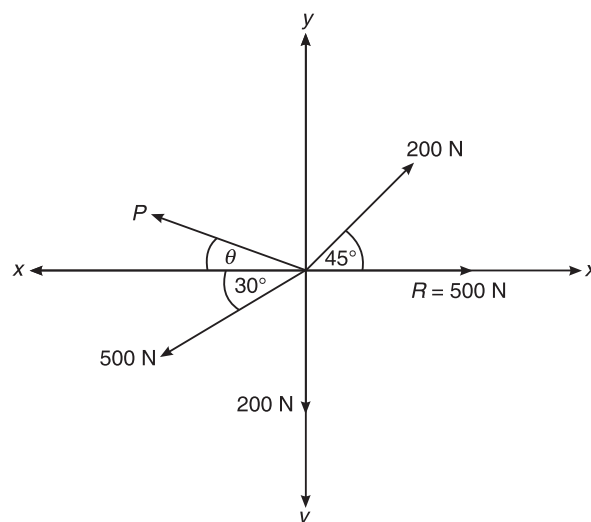

Figure 3.6 Example 3.6.

Solution We know that

$$\Sigma F_x = R_x$$

$$\Sigma F_y = R_y$$

Resolving forces along the x -direction,

$$\Sigma F_x = R_x = R \cos \theta = R$$

$$\text{or } \Sigma F_x = 500 \text{ N}$$

$$\text{or } -P \cos \theta + 200 \cos 45^\circ - 500 \cos 30^\circ = 500$$

$$\text{or } -P \cos \theta + 291.591 = 500$$

$$\text{or } P \cos \theta = -791.59 \text{ N} \quad \text{(i)}$$

Also, $\Sigma F_y = R_y = 0$
 or $P \sin \theta + 200 \sin 45^\circ - 500 \sin 30^\circ - 200 = 0$
 or $P \sin \theta - 308.579 = 0$
 or $P \sin \theta = 308.579$ (ii)

Squaring both equations (i) and (ii) and then adding,

$$P^2 \cos^2 \theta + P^2 \sin^2 \theta = (-791.591)^2 + (308.579)^2$$

or $P^2 = 721837.31$

or $P = 849.61 \text{ N}$ **Ans.**

Dividing Eq. (ii) by Eq. (i) gives

$$\frac{\sin \theta}{\cos \theta} = \tan \theta = \frac{308.579}{-791.591}$$

or $\theta = \tan^{-1} \left(\frac{308.579}{-791.591} \right) = 21.297^\circ$ **Ans.**

Example 3.7 26 kN force is the resultant of the two forces, one of which is as shown in Figure 3.7. Determine the other force. *VTU(August 2004)*

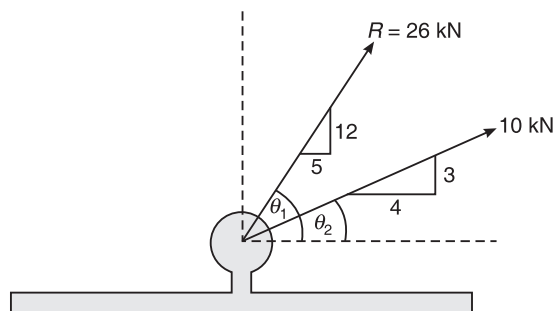

Figure 3.7 Example 3.7.

Solution Let P be the unknown force, which makes an angle θ with the horizontal.

Here:

$$R = 26 \text{ kN}$$

$$\theta_1 = \tan^{-1} \left(\frac{12}{5} \right) = 67.38^\circ$$

$$\theta_2 = \tan^{-1} \left(\frac{3}{4} \right) = 36.87^\circ$$

$$\Sigma F_x = R_x$$

or $P \cos \theta + 10 \cos 36.87^\circ = 26 \cos 67.38^\circ$

or $P \cos \theta = 26 \cos 67.38^\circ - 10 \cos 36.87^\circ = 2$ (i)

40 ELEMENTS OF CIVIL ENGINEERING AND ENGINEERING MECHANICS

Also, $\Sigma F_y = R_y$
 or $P \sin \theta + 10 \sin 36.86^\circ = 26 \sin 67.38^\circ$
 or $P \sin \theta = 26 \sin 67.38^\circ - 10 \sin 36.86^\circ = 18$ (ii)

Dividing Eq. (ii) by Eq. (i) gives

$$\frac{P \sin \theta}{P \cos \theta} = \frac{18}{2}$$

or $\tan \theta = 9$
 $\therefore \theta = \tan^{-1}(9) = 83.66^\circ$ **Ans.**

Squaring (i) and (ii) and then adding

$$P^2 \sin^2 \theta + P^2 \cos^2 \theta = 4 + 324 = 328$$

or $P^2 = 328$
 $\therefore P = 18.11 \text{ kN}$ **Ans.**

Example 3.8 The resultant of a force system on a bracket as shown in Figure 3.8 is acting vertically upwards. If the angle 30° between the two 4 kN forces is fixed; find the angle θ . Also determine the magnitude of the resultant.

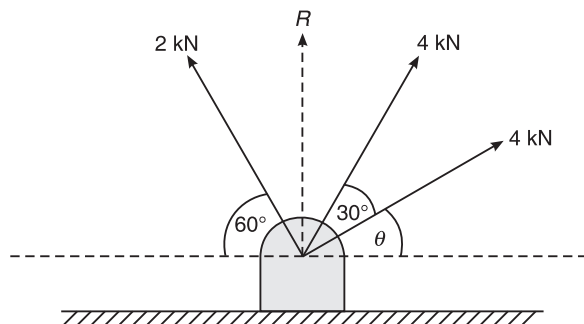

Figure 3.8 Example 3.8.

Solution

$$\Sigma F_x = R_x = 0$$

$$\Sigma F_y = R_y = R$$

$$\Sigma F_x = 0$$

or $4 \cos \theta + 4 \cos(30 + \theta) - 2 \cos 60^\circ = 0$

or $4 \cos \theta + 4 \cos(30 + \theta) = 2 \times \frac{1}{2}$

or $\cos \theta + \cos(30 + \theta) = \frac{1}{4}$

or $\cos \theta + \cos 30^\circ \cdot \cos \theta - \sin 30^\circ \cdot \sin \theta = \frac{1}{4}$

$$2 \cdot \cos(15^\circ + \theta) \cdot \cos 15^\circ = \frac{1}{4}$$

$$2 \times \cos(15^\circ + \theta) \times 0.966 = \frac{1}{4}$$

$$\cos(15 + \theta) = \frac{1}{2 \times 0.966}$$

$$15 + \theta = \cos^{-1} \left(\frac{1}{2 \times 0.966} \right) = \cos^{-1} (0.517) = 67.57^\circ$$

$$\theta = 67.57^\circ$$

Also,

$$\Sigma F_y = R$$

\therefore

$$R = 4 \sin 67.57^\circ + 4 \sin 97.57^\circ + 2 \sin 60^\circ = 9.394 \text{ kN} \quad \text{Ans.}$$

Example 3.9 Four forces acting on a hook are shown in Figure 3.9. Determine the direction of the force 150 N such that the hook is pulled in the x -direction. Determine the resultant force in the x -direction.

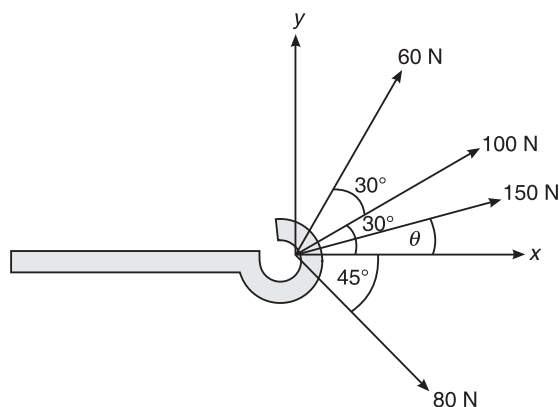

Figure 3.9 Example 3.9.

Solution

$$\Sigma F_x = R$$

$$\Sigma F_y = 0$$

For $\Sigma F_y = 0$, we have

$$-80 \sin 45^\circ + 60 \sin 60^\circ + 100 \sin 30^\circ + 150 \sin \theta = 0$$

or

$$150 \sin \theta = 45.39$$

or

$$\theta = \sin^{-1} \left(\frac{45.39}{150} \right) = 17.61^\circ$$

For $\Sigma F_x = R$, we have

$$80 \cos 45^\circ + 60 \cos 60^\circ + 100 \cos 30^\circ + 150 \cos 17.61^\circ = R$$

\therefore

$$R = 316.142 \text{ N}$$

Ans.

42 ELEMENTS OF CIVIL ENGINEERING AND ENGINEERING MECHANICS

Example 3.10 Four forces are acting on a bolt as shown in Figure 3.10. Determine the magnitude and direction of the resultant force.

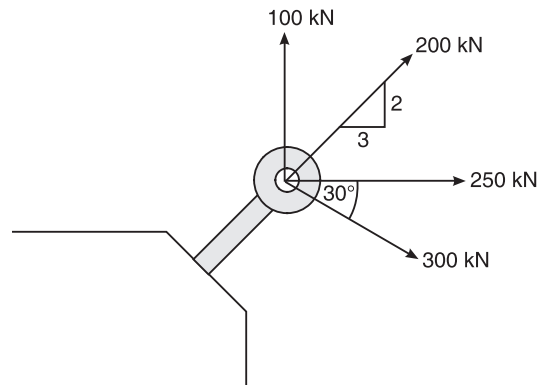

Figure 3.10 Example 3.10.

Solution Magnitude of the resultant,

$$R = \sqrt{\Sigma F_x^2 + \Sigma F_y^2}$$

$$\Sigma F_x = 250 + 300 \cos 30^\circ + 200 \cos 33.69^\circ = 676.218$$

$$\Sigma F_y = 100 - 300 \sin 30^\circ + 200 \sin 33.69^\circ = 60.939$$

$$R = \sqrt{(676.218)^2 + (60.939)^2} = 678.958 \text{ kN}$$

Ans.

Direction of resultant (θ)

$$\theta = \tan^{-1} \left(\frac{\Sigma F_y}{\Sigma F_x} \right)$$

$$\theta = \tan^{-1} \left(\frac{60.939}{676.218} \right) = 5.149^\circ$$

Ans.

Example 3.11 Two forces of 800 N and 600 N act at a point as shown in Figure 3.11. The resultant of the two forces is 1200 N. Determine θ between the forces and the direction of the resultant.

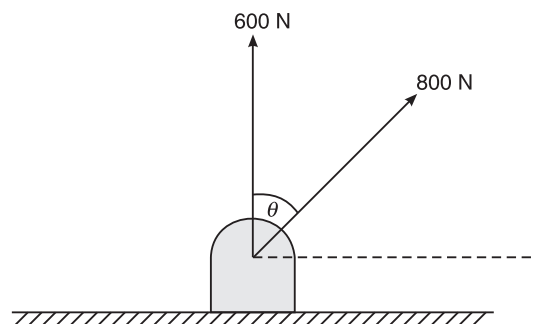

Figure 3.11 Example 3.11.

Solution

$$\Sigma F_x = 800 \sin \theta$$

$$\Sigma F_y = 600 + 800 \cos \theta$$

$$R = \sqrt{\Sigma F_x^2 + \Sigma F_y^2}$$

$$\text{or } (1200)^2 = (800)^2 \sin^2 \theta + (600)^2 + (800)^2 \cos^2 \theta + 2 \times 800 \times 600 \times \cos \theta$$

$$\text{or } (12)^2 = 64 + 36 + 2 \times 8 \times 6 \cos \theta$$

$$\text{or } 144 = 100 + 96 \cos \theta$$

$$\text{or } 44 = 96 \cos \theta$$

$$\text{or } \cos \theta = \frac{44}{96}$$

$$\therefore \theta = \cos^{-1} \left(\frac{44}{96} \right) = 62.72^\circ$$

Ans.

From the relation, $\tan \phi = \frac{Q \sin \theta}{P + Q \cos \theta}$, we have

$$\tan \phi = \frac{800 \sin 62.72^\circ}{600 + 800 \cos 62.72^\circ} = 0.736$$

or $\phi = 36.34^\circ$ with respect to the vertical

\therefore The direction of the resultant with respect to the horizontal $= 90^\circ - 36.34^\circ = 53.66^\circ$. **Ans.**

Example 3.12 Determine the resultant of the system of forces acting on a body as shown in Figure 3.12. Take the co-ordinate directions as shown in the figure.

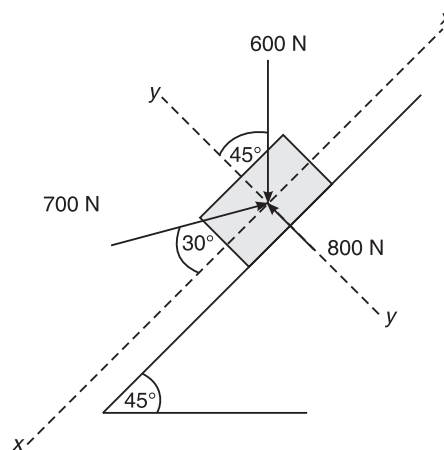

Figure 3.12 Example 3.12.

Solution

$$R = \sqrt{\Sigma F_x^2 + \Sigma F_y^2}$$

$$\Sigma F_x = 700 \cos 30^\circ - 600 \sin 45^\circ = 181.953 \text{ N}$$

$$\Sigma F_y = 800 - 600 \cos 45^\circ - 700 \sin 30^\circ = 25.736 \text{ N}$$

44 ELEMENTS OF CIVIL ENGINEERING AND ENGINEERING MECHANICS

\therefore $R = 183.764 \text{ N}$ **Ans.**
and $\theta = 8.05^\circ$ **Ans.**

Example 3.13 A force of 200 N is acting on a block as shown in Figure 3.13. Find the components of the force along the horizontal and vertical axes. *VTU(January 2007)*

Solution $F_x = -200 \cos 60^\circ = -100 \text{ N}$ **Ans.**
 $F_y = -200 \sin 60^\circ = -173.2 \text{ N}$ **Ans.**

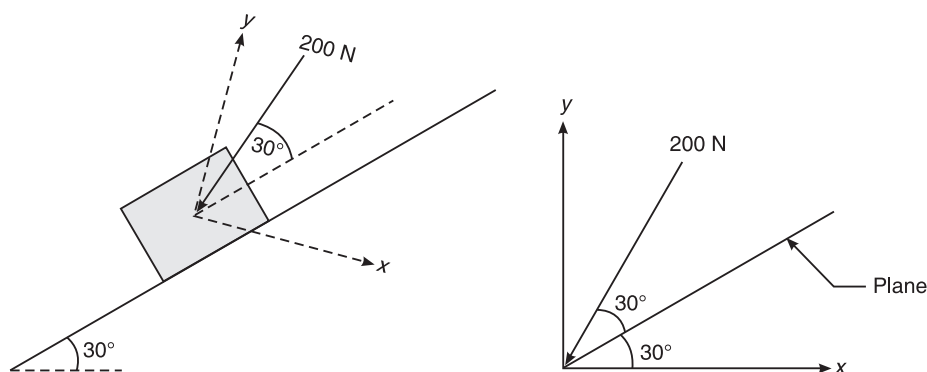

Figure 3.13 Example 3.13.

Example 3.14 Determine the resultant force acting on the structure at point O both in magnitude and direction (Figure 3.14). *VTU(January 2007)*

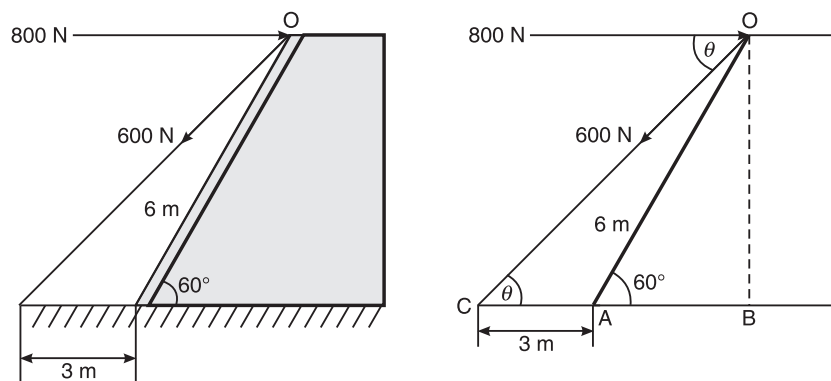

Figure 3.14 Example 3.14.

Solution In triangle OAB,

$$\cos 60^\circ = \frac{AB}{6}$$

\therefore $AB = 3 \text{ m}; \sin 60^\circ = \frac{OB}{6}$

\therefore $OB = 5.196 \text{ m}$

In triangle OCB,

$$\tan \theta = \frac{OB}{BC} = \frac{5.196}{6}$$

$$\therefore \theta = \tan^{-1} \left(\frac{5.196}{6} \right) = 40.89^\circ$$

The magnitude of resultant R is given by

$$R = \sqrt{\Sigma F_x^2 + \Sigma F_y^2}$$

$$\text{Now, } \Sigma F_x = 800 - 600 \cos 40.89^\circ = 346.419 \text{ N}$$

$$\text{and } \Sigma F_y = -600 \sin 40.89^\circ = -392.765 \text{ N}$$

$$\therefore R = \sqrt{(346.419)^2 + (-392.765)^2} = 523.708 \text{ N}$$

$$\text{or } R = 523.708 \text{ N} \quad \text{Ans.}$$

The direction α of the resultant is given by

$$\alpha = \tan^{-1} \left(\frac{\Sigma F_y}{\Sigma F_x} \right)$$

$$\therefore \alpha = \tan^{-1} \left(\frac{-392.765}{346.419} \right) = -48.59^\circ \quad \text{Ans.}$$

Example 3.15 A 100 N vertical force is applied to a shaft at A as shown in Figure 3.15. Determine the effect of 100 N force at O.

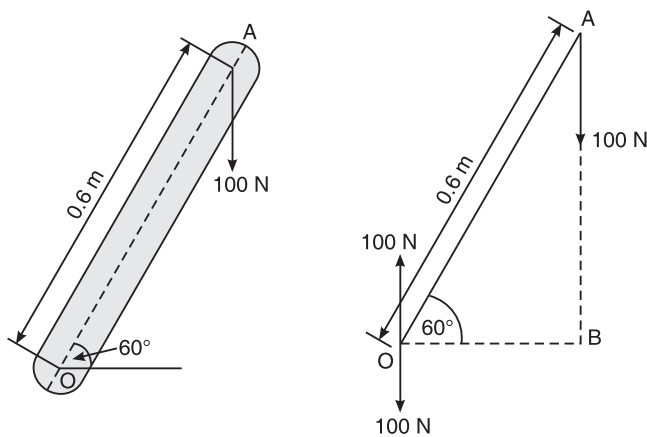

Figure 3.15 Example 3.15.

Solution Apply equal and opposite forces of 100 N at O as shown in Figure 3.16. The effect produced as shown in Figure 3.16 is:

- A downward force 100 N at O
- Clockwise couple of $100 \times 0.3 = 30 \text{ N}\cdot\text{m}$

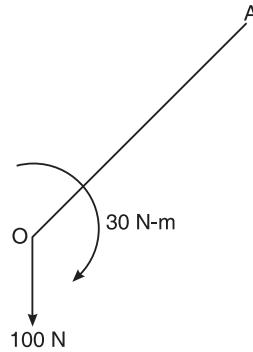

Figure 3.16 Example 3.15.

Ans.

Example 3.16 Reduce the force acting at A (Figure 3.17) into a system of force and couple at point O.

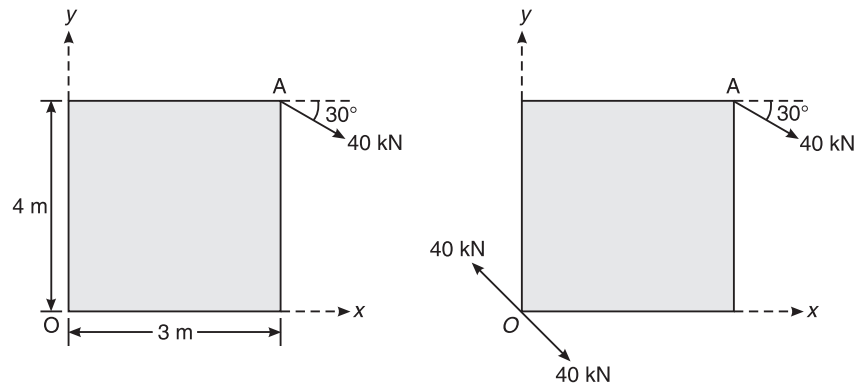

Figure 3.17 Example 3.16.

Solution Apply equal and opposite forces of 40 kN at O parallel to the given force.

Couple at point O, $M_O = 40 \cos 30^\circ \times 4 + 40 \sin 30^\circ \times 3 = 198.56 \text{ kN-m}$, clockwise. See Figure 3.18.

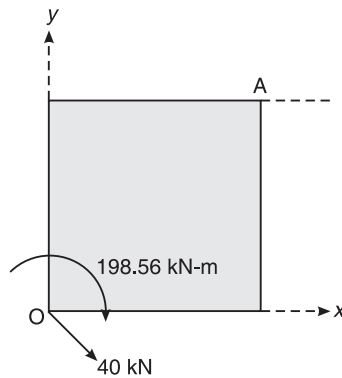

Figure 3.18 Example 3.16.

Ans.

EXERCISE PROBLEMS

1. Determine the resultant of the four forces acting on a particle as shown in Figure 3.19.

[Ans.: $R = 303.4 \text{ N}$, $\theta = 68.85^\circ$]

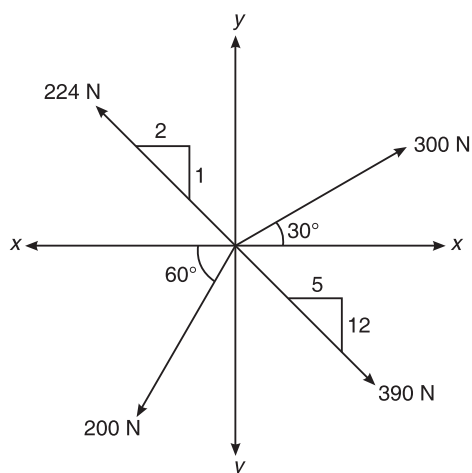

Figure 3.19

2. Determine the resultant of the coplanar concurrent force system shown in Figure 3.20.

[Ans.: $R = 155.81 \text{ N}$, $\theta = -76.64^\circ$]

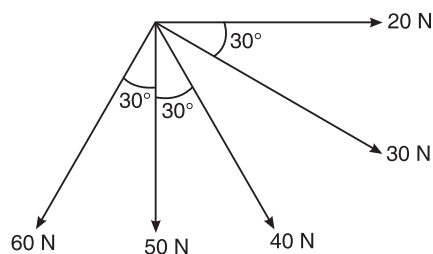

Figure 3.20

3. Determine the resultant of the force system shown in Figure 3.21.

[Ans.: $R = 104.84 \text{ kN}$, $\theta = -11.52^\circ$]

4. The force system as shown in Figure 3.22 has a resultant of 240 N acting up along the y-axis. Compute the value of force P and its inclination with x-axis.

[Ans.: $P = 151.16 \text{ N}$ $\alpha = 74.51^\circ$]

48 ELEMENTS OF CIVIL ENGINEERING AND ENGINEERING MECHANICS

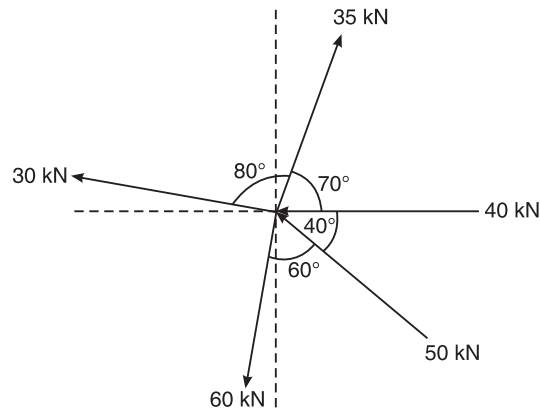

Figure 3.21

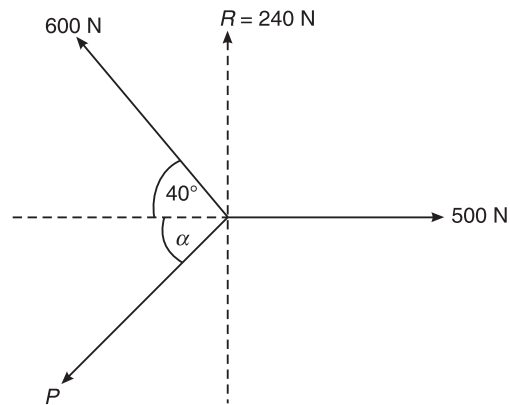

Figure 3.22

5. The following forces, as shown in Figure 3.23, are acting at point A. Determine the resultant.
- (i) A force of 200 kN directed towards 30° of east of south.
 - (ii) A force of 100 kN directed towards 60° of west of north.
 - (iii) A force of 300 kN directed towards 40° of west of south.
 - (iv) A force of 50 kN directed towards north.
 - (v) A force of 150 kN directed towards west.
- [Ans.: $R = 447.604$ kN, $\theta = 42.61^\circ$]

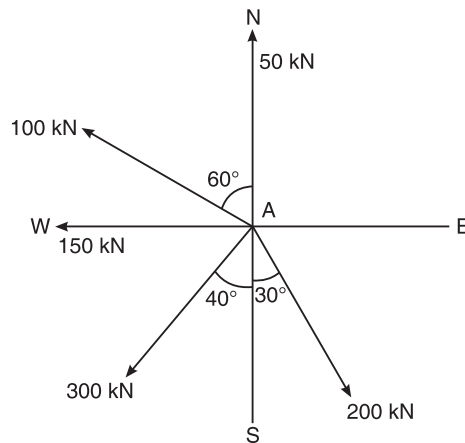

Figure 3.23

6. The two forces P and Q are acting on a bolt at A , as shown in Figure 3.24. Determine the magnitude and direction of the resultant. [Ans.: $R = 91.23 \text{ N}$, $\theta = 67.97^\circ$]

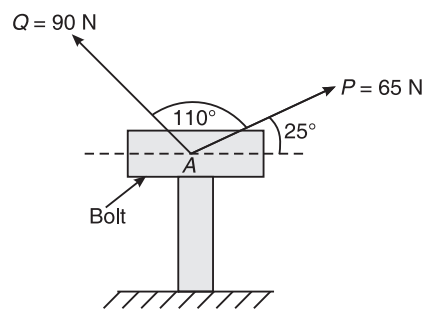

Figure 3.24

7. Figure 3.25 shows the top view of a car, pulled by two cables AB and AD. The car is moving along AC. If the force in cable AB is 100 N, calculate the force in AD and the resultant. [Ans.: $F_{AD} = 70.711 \text{ N}$, $R = 136.603 \text{ N}$]

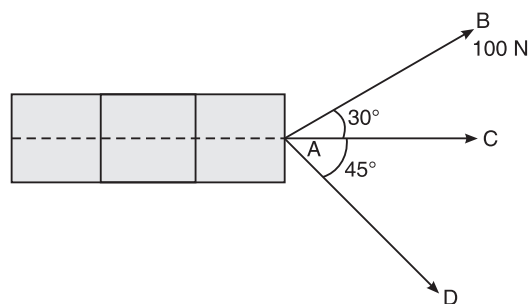

Figure 3.25

50 ELEMENTS OF CIVIL ENGINEERING AND ENGINEERING MECHANICS

8. A collar which may slide on a vertical rod is subjected to three forces as shown in Figure 3.26. Determine:
- (a) the value of angle α for which the resultant of the three forces is horizontal, and
 (b) the corresponding magnitude of the resultant. [Ans.: $\alpha = 27.073^\circ$, $R = 155$ N]

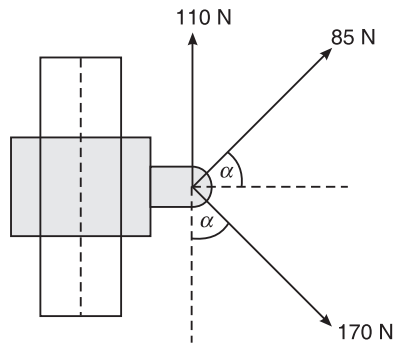

Figure 3.26

Hint:

$$F_x = R, F_y = 0$$

$$\sin \alpha = -1.294 + 2 \cos \alpha$$

Squaring,

$$\sin^2 \alpha = (-1.294 + 2 \cos \alpha)^2$$

$$\sin^2 \alpha = 1 - \cos^2 \alpha$$

$$5 \cos^2 \alpha - 5.176 \cos \alpha + 0.67 = 0, \quad \cos \alpha = \frac{-b \pm \sqrt{b^2 - 4ac}}{2a}$$

COPLANAR NON-CONCURRENT FORCE SYSTEM

DEFINITION

If two or more forces are acting in a single plane, but not passing through the single point, such a force system is known as coplanar non-concurrent force system.

In a coplanar non-concurrent force system, we can calculate the magnitude, direction and position of the resultant force as follows:

$$\text{Magnitude of resultant, } R = \sqrt{\Sigma F_x^2 + \Sigma F_y^2}$$

$$\text{Direction of resultant, } \theta = \tan^{-1} \left(\frac{\Sigma F_y}{\Sigma F_x} \right)$$

Position of resultant: The position of the resultant means the calculation of d , or x and y intercepts as shown in Figure 4.1.

$R \times d =$ algebraic sum of moments of number of forces about that point.

$$\therefore d = \frac{\Sigma M}{R}$$

$$\text{and } x\text{-intercept: } x = \left| \frac{\Sigma M}{\Sigma F_y} \right|$$

$$\text{and } y\text{-intercept: } y = \left| \frac{\Sigma M}{\Sigma F_x} \right|$$

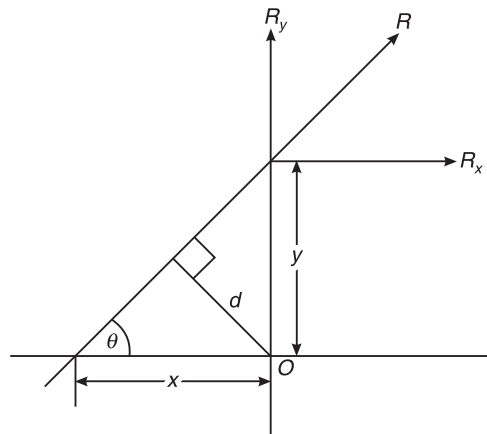

Figure 4.1

PROBLEMS ON COPLANAR NON-CONCURRENT FORCE SYSTEM

Tips to Solve the Problems

1. In a coplanar non-concurrent force system, the magnitude, direction and position of resultant can be determined.
2. Calculate the algebraic sum of all the forces acting in the x -direction (i.e. ΣF_x) and also in the y -direction (i.e. ΣF_y).
3. Determine the magnitude of the resultant using the formula, $R = \sqrt{\Sigma F_x^2 + \Sigma F_y^2}$.
4. Determine the direction of the resultant using the formula, $\theta = \tan^{-1} \left(\frac{\Sigma F_y}{\Sigma F_x} \right)$.
5. The position of resultant can be determined by using the Varignon's theorem or using

the formulae $d = \left| \frac{\Sigma M}{R} \right|$, x -intercept = $\left| \frac{\Sigma M}{\Sigma F_y} \right|$ and y -intercept = $\left| \frac{\Sigma M}{\Sigma F_x} \right|$.

Example 4.1 Find the moment of the force $F = 600$ N about A as shown in Figure 4.2.

VTU (January 2007)

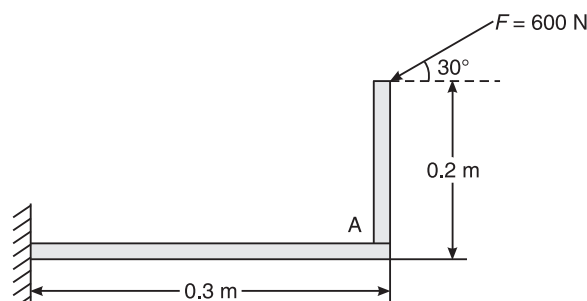
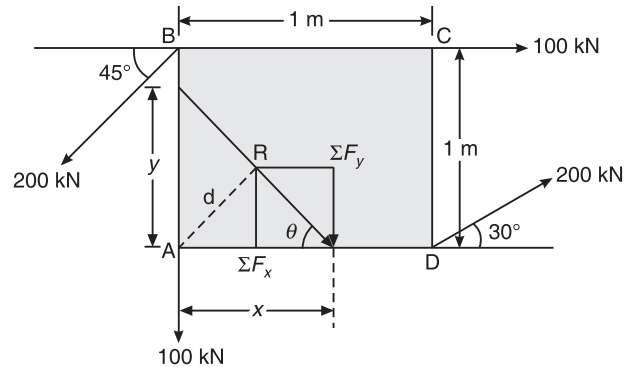

Figure 4.2 Example 4.1.

Solution Moment of force, $F = 600 \text{ N}$ about A is
 $M_A = -600 \cos 30^\circ \times 0.2 + 600 \sin 30^\circ \times 0.3$
 $\therefore M_A = -13.923 \text{ N-m}$

Ans.

Example 4.2 A rigid plate ABCD is subjected to forces as shown in Figure 4.3. Compute the magnitude, direction and line of action of the resultant of the system with reference to the point A.

**Figure 4.3** Example 4.2.

Solution

$$R = \sqrt{\Sigma F_x^2 + \Sigma F_y^2}$$

$$\Sigma F_x = 100 + 200 \cos 30^\circ - 200 \cos 45^\circ = 131.78 \text{ kN}$$

$$\Sigma F_y = -100 - 200 \sin 45^\circ - 200 \sin 30^\circ = -141.42 \text{ kN}$$

$\therefore R = \sqrt{(131.78)^2 + (-141.42)^2} = 193.30 \text{ kN}$

Ans.

Also, $\tan \theta = \frac{\Sigma F_y}{\Sigma F_x} = \frac{-141.42}{131.78} = -1.073$

$\therefore \theta = \tan^{-1}(-1.073) = -42.02^\circ$

Ans.

The line of action of 100 kN is directly passing through the point A, therefore, the moment produced by the 100 kN force about A is zero.

$$\begin{aligned} \Sigma M_A &= 100 \times 0 + 200 \sin 45^\circ \times 0 - 200 \cos 45^\circ \times 1 \\ &\quad + 100 \times 1 - 200 \sin 30^\circ \times 1 + 200 \cos 30^\circ \times 0 \\ &= -200 \cos 45^\circ = -141.42 \text{ kN} \end{aligned}$$

$\therefore d = \frac{\Sigma M_A}{R} = \left| \frac{-141.42}{193.3} \right| = 0.732 \text{ m}$

$$\begin{aligned} x\text{-intercept} &= \left| \frac{\Sigma M_A}{\Sigma F_y} \right| \\ &= \left| \frac{-141.42}{-141.42} \right| = 1 \text{ m} \end{aligned}$$

54 ELEMENTS OF CIVIL ENGINEERING AND ENGINEERING MECHANICS

$$\begin{aligned} \text{y-intercept} &= \left| \frac{-141.42}{131.78} \right| \\ &= 1.073 \text{ m} \end{aligned}$$

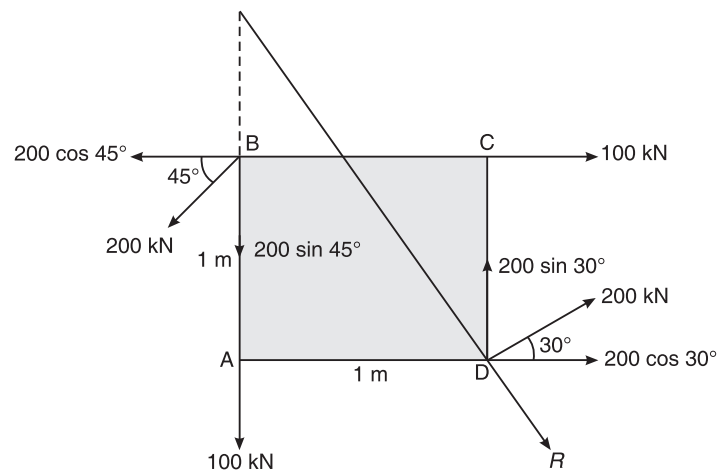

Figure 4.4 Example 4.2 showing the position of resultant.

Ans.

Example 4.3 For the non-concurrent coplanar system shown in Figure 4.5, determine the magnitude, direction and position of the resultant force with reference to A. VTU (August 2003)

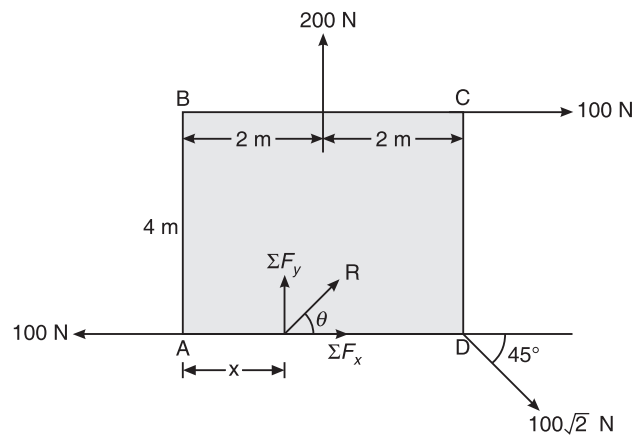

Figure 4.5 Example 4.3.

Solution

$$\begin{aligned} R &= \sqrt{\Sigma F_x^2 + \Sigma F_y^2} \\ \Sigma F_x &= 100 - 100 + 100\sqrt{2} \cos 45^\circ + 0 = 100 \text{ N} \\ \Sigma F_y &= 200 - 100\sqrt{2} \sin 45^\circ + 0 = 100 \text{ N} \\ R &= \sqrt{(100)^2 + (100)^2} \\ &= 100\sqrt{2} \text{ N} = 141.421 \text{ N} \end{aligned}$$

Ans.

$$\tan \theta = \frac{\Sigma F_y}{\Sigma F_x} = \frac{100}{100} = 1$$

∴

$$\theta = 45^\circ$$

Ans.

$$d = \frac{\Sigma M_A}{R}$$

$$\begin{aligned} \Sigma M_A &= 100 \times 0 + 100\sqrt{2} \sin 45^\circ \times 4 + 100 \times 4 - 200 \times 2 \\ &= 100\sqrt{2} \times \sin 45^\circ \times 4 = 400 \text{ N-m} \end{aligned}$$

∴

$$d = \frac{400}{100\sqrt{2}} = \frac{4}{\sqrt{2}} = 2\sqrt{2} = 2.82 \text{ m}$$

$$\text{x-intercept} = \left| \frac{\Sigma M_A}{\Sigma F_y} \right| = \left| \frac{400}{100} \right| = 4 \text{ m}$$

$$\text{y-intercept} = \left| \frac{\Sigma M_A}{\Sigma F_x} \right| = \left| \frac{400}{100} \right| = 4 \text{ m}$$

Ans.

Example 4.4 Find the magnitude, direction and position of the resultant force with reference to A of the forces shown in Figure 4.6.

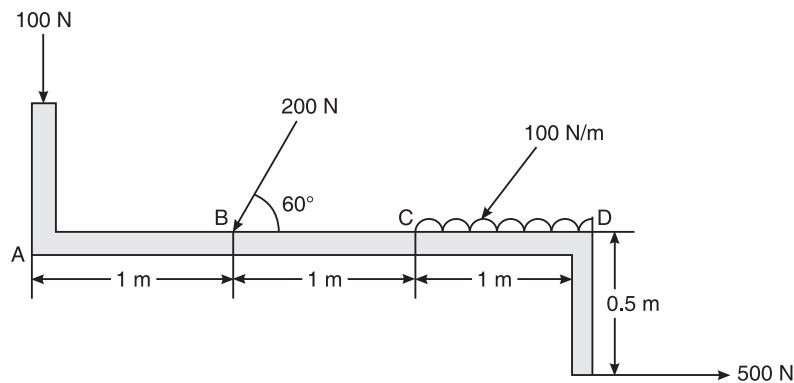

Figure 4.6 Example 4.4.

Solution Convert the uniformly distributed load (UDL) into point load, i.e. $100 \text{ N/m} \times 1 \text{ m} = 100 \text{ N}$, which is acting at the centre of the span CD.

$$\Sigma F_x = -200 \cos 60^\circ + 500 = 400 \text{ N}$$

$$\Sigma F_y = -100 - 100 - 200 \sin 60^\circ = -373.21 \text{ N}$$

∴

$$R = \sqrt{(400)^2 + (-373.21)^2} = 547.07 \text{ N}$$

Ans.

and

$$\tan \theta = \frac{\Sigma F_y}{\Sigma F_x} = \frac{-373.21}{400}$$

or

$$\theta = -43.02^\circ$$

Ans.

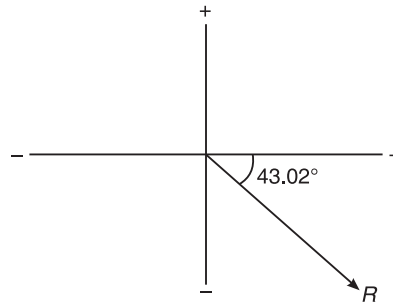

Figure 4.7 Example 4.4 showing the direction of resultant.

Taking moments about A,

$$\Sigma M_A = 200 \sin 60^\circ \times 1 + 100 \times 2.5 - 500 \times 0.5 = 173.21 \text{ N}\cdot\text{m}$$

$$d = \frac{\Sigma M_A}{R} = \frac{173.21}{547.07} = 173.21 \text{ N}\cdot\text{m}$$

$$x\text{-intercept} = \left| \frac{\Sigma M_A}{\Sigma F_y} \right| = \frac{173.21}{373.21} = 0.464 \text{ m}$$

$$y\text{-intercept} = \left| \frac{\Sigma M_A}{\Sigma F_x} \right| = \frac{173.21}{400} = 0.433 \text{ m}$$

Ans.

Example 4.5 A bracket is subjected to five forces and a couple as shown in Figure 4.8. Determine the magnitude, direction and the line of action of the resultant.

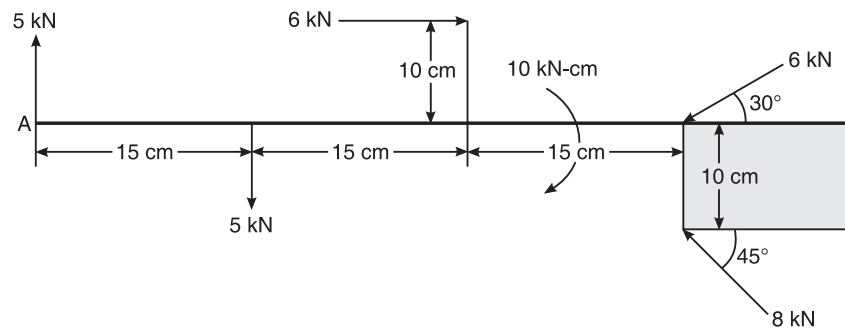

Figure 4.8 Example 4.5.

Solution

$$R = \sqrt{\Sigma F_x^2 + \Sigma F_y^2}$$

$$\Sigma F_x = 6 - 6 \cos 30^\circ - 8 \cos 45^\circ = -4.853 \text{ kN}$$

$$\Sigma F_y = 5 - 6 \sin 30^\circ + 8 \sin 45^\circ - 5 = 2.656 \text{ kN}$$

\therefore

$$R = \sqrt{\Sigma F_x^2 + \Sigma F_y^2}$$

or

$$R = \sqrt{(-4.853)^2 + (2.656)^2} = 5.532 \text{ kN}$$

Ans.

Also,
$$\theta = \tan^{-1} \frac{\Sigma F_y}{\Sigma F_x}$$

$$\therefore \theta = \tan^{-1} \left(\frac{2.656}{-4.853} \right) = -28.69^\circ \quad \text{Ans.}$$

Line of action of the resultant: Here we can take moment about any point

$$d = \frac{\Sigma M_A}{R}$$

$$\Sigma M_A = 5 \times 15 + 6 \times 10 + 6 \sin 30^\circ \times 45 + 8 \cos 45^\circ \times 10 - 8 \sin 45^\circ \times 45 + 10$$

$$= 82 \text{ kN-cm}$$

$$d = \left| \frac{82}{5.532} \right| = 14.825 \text{ cm}$$

$$x\text{-intercept} = \left| \frac{\Sigma M_A}{F_y} \right| = \left| \frac{82}{2.656} \right| = 30.873 \text{ cm}$$

$$y\text{-intercept} = \left| \frac{\Sigma M_A}{F_x} \right| = \left| \frac{82}{-4.853} \right| = 16.897 \text{ cm}$$

Calculation of equivalent force couple at A means the calculation of R and M_A .

Ans.

Example 4.6 A bracket is subjected to a coplanar force system as shown in Fig. 4.9. Determine the magnitude and line of action of single resultant of the system. If the resultant is to pass through B, what should be the magnitude and direction of a couple?

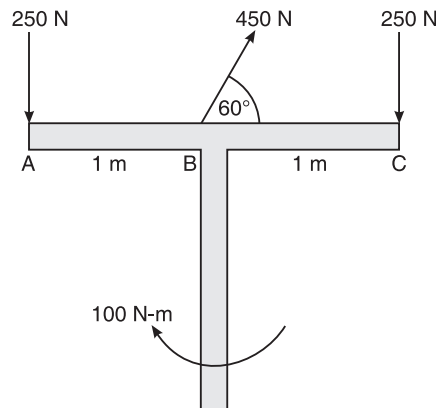

Figure 4.9 Example 4.6.

Solution

$$R = \sqrt{\Sigma F_x^2 + \Sigma F_y^2}$$

$$\Sigma F_x = 450 \cos 60^\circ = 225 \text{ N}$$

$$\Sigma F_y = 450 \sin 60^\circ - 500 = -110.29 \text{ N}$$

58 ELEMENTS OF CIVIL ENGINEERING AND ENGINEERING MECHANICS

$$\therefore R = \sqrt{\Sigma F_x^2 + \Sigma F_y^2}$$

$$\text{or } R = \sqrt{(-110.29)^2 + (225)^2} = 250.58 \text{ N}$$

Ans.

$$d = \frac{\Sigma M_A}{R}$$

$$\begin{aligned} \Sigma M_A &= -450 \sin 60^\circ \times 1 + 250 \times 2 + 100 \\ &= -389.71 + 600 = 210.29 \text{ N-m} \end{aligned}$$

$$\therefore d = \left| \frac{210.29}{250.58} \right| = 0.84 \text{ m}$$

$$x\text{-intercept} = \left| \frac{\Sigma M_A}{F_y} \right| = \left| \frac{210.29}{110.29} \right| = 1.906 \text{ m}$$

Ans.

A couple 100 N-m is acting on a bracket when the resultant is at a distance of 1.906 m from A.
When the resultant is passing through B, $x\text{-intercept} = 1 \text{ m}$

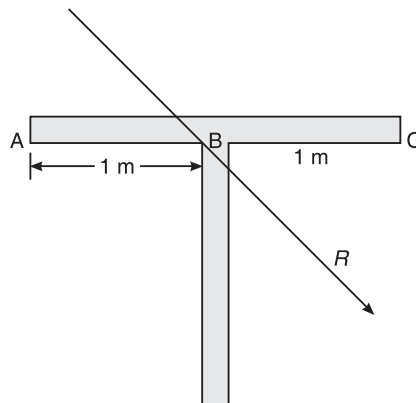
**Figure 4.10** Example 4.6.

A couple M is acting on a bracket instead of 100 N-m

$$\text{We know that } x\text{-intercept} = \left| \frac{\Sigma M_A}{\Sigma F_y} \right|$$

$$\text{i.e. } \Sigma M_A = \Sigma F_y$$

$$\text{or } 1 = \frac{\Sigma M_A}{\Sigma F_y}$$

$$\text{or } -450 \sin 60^\circ + 500 + M = 110.29 \quad \text{or} \quad 110.29 + M = 110.29$$

$$\therefore M = 110.29 - 110.29 = 0$$

No couple is therefore acting when the resultant is passing through B.

Ans.

Example 4.7 Determine the resultant of a system of forces as shown in Figure 4.11, acting on a $40\text{ mm} \times 40\text{ mm}$ size lamina. Each grid is of size $10\text{ mm} \times 10\text{ mm}$. Determine the x and y intercepts also.

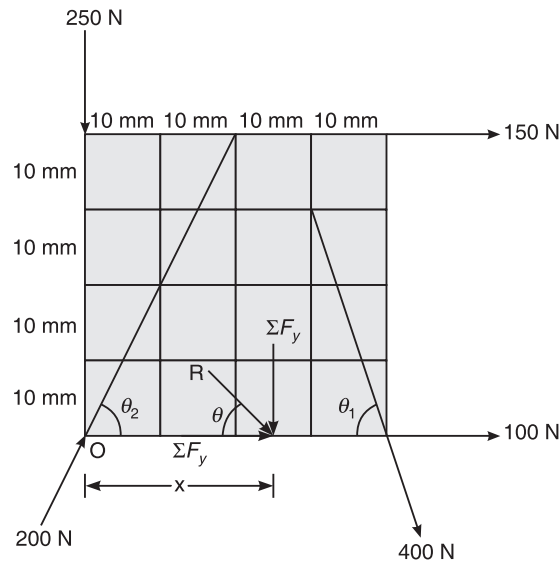

Figure 4.11 Example 4.7.

Solution $\tan \theta_2 = \left(\frac{40}{20}\right)$; $\theta_2 = \tan^{-1}(2) = 63.43^\circ$

$$\tan \theta_1 = \frac{30}{10}; \theta_1 = \tan^{-1}(3) = 71.57^\circ$$

$$R = \sqrt{\Sigma F_x^2 + \Sigma F_y^2}$$

$$\Sigma F_x = 150 + 400 \cos 71.57^\circ + 200 \cos 63.43^\circ + 100 = 465.916\text{ N}$$

$$\Sigma F_y = -250 - 400 \sin 71.56^\circ + 200 \sin 63.43^\circ = -450.588\text{ N}$$

$$\therefore R = \sqrt{\Sigma F_x^2 + \Sigma F_y^2} = 648.169\text{ N} \quad \text{Ans.}$$

and $\theta = \tan^{-1} \frac{\Sigma F_y}{\Sigma F_x} = -44.04^\circ \quad \text{Ans.}$

$$x\text{-intercept} = \left| \frac{\Sigma M}{\Sigma F_y} \right|$$

$$\begin{aligned} \Sigma M &= 0 + 150 \times 40 + 400 \sin 71.56^\circ \times 40 \\ &= 21178.933\text{ N-mm} \end{aligned}$$

$$x\text{-intercept} = \left| \frac{21178.487}{-450.61} \right| = 47\text{ mm}$$

and $y\text{-intercept} = \left| \frac{21178.487}{460.93} \right| = 45.455\text{ mm} \quad \text{Ans.}$

60 ELEMENTS OF CIVIL ENGINEERING AND ENGINEERING MECHANICS

Example 4.8 Determine the position of resultant of a force system if the external moment $M = 3 \text{ N-m}$ at the point P (20, 10) as shown in Figure in 4.12.

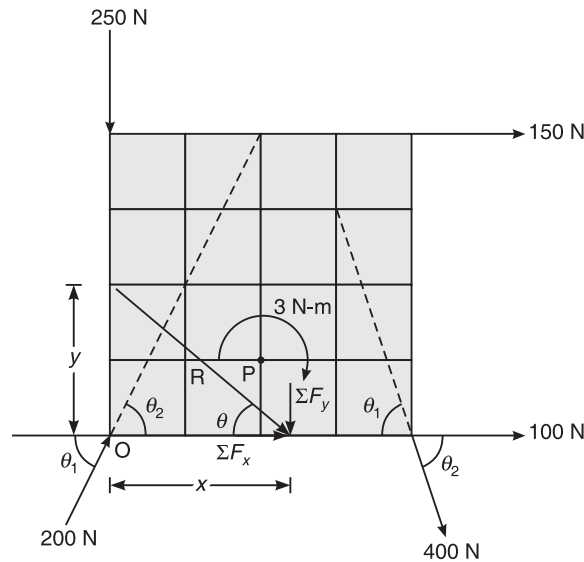

Figure 4.12 Example 4.8.

Solution $\theta_1 = \tan^{-1}(3) = 71.57^\circ$; $\theta_2 = \tan^{-1}(2) = 63.43^\circ$ (see Example 4.7)

$$\Sigma F_x = 150 + 400 \cos 71.57^\circ + 200 \cos 63.43^\circ + 100 = 465.982 \text{ N}$$

$$\Sigma F_y = -250 - 400 \sin 71.57^\circ + 200 \sin 63.43^\circ = -450.61 \text{ N}$$

$$\therefore R = \sqrt{\Sigma F_x^2 + \Sigma F_y^2} = 648.219 \text{ N} \quad \text{Ans.}$$

$$\text{and } \theta = \tan^{-1} \frac{\Sigma F_y}{\Sigma F_x} = -44.04^\circ \quad \text{Ans.}$$

$$x\text{-intercept} = \left| \frac{\Sigma M}{\Sigma F_y} \right|$$

$$\text{Now, } \Sigma M_O = 0 + 150 \times 40 + 400 \sin 71.57^\circ \times 40 = 21178.487 \text{ N-mm}$$

$$\text{Hence, } d = \frac{\Sigma M_O}{R}$$

$$= \left| \frac{21178.487}{-648.219} \right| = 32.67 \text{ mm}$$

$$x\text{-intercept} = \left| \frac{21178.487}{-450.61} \right| = 47 \text{ mm}$$

$$y\text{-intercept} = \left| \frac{21178.487}{365.9821} \right| = 45.449 \text{ mm} \quad \text{Ans.}$$

Example 4.9 Determine the magnitude and y-intercept of resultant of force system acting on lamina as shown in Figure 4.13. VTU (February 2003)

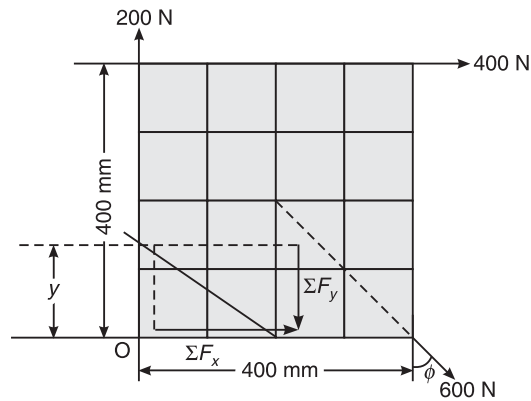

Figure 4.13 Example 4.9.

Solution

$$R = \sqrt{\Sigma F_x^2 + \Sigma F_y^2}$$

$$\tan \phi = \frac{20}{20} = 1; \quad \phi = 45^\circ$$

$$\Sigma F_x = 400 + 600 \sin 45^\circ = 824.264 \text{ N}; \quad \Sigma F_y = 200 - 600 \cos 45^\circ = -224.264 \text{ N}$$

$$R = \sqrt{(824.264)^2 + (-224.264)^2} = 854.228 \text{ N} \quad \text{Ans.}$$

$$\theta = \tan^{-1} \left(\frac{\Sigma F_y}{\Sigma F_x} \right) = -15.22^\circ$$

$$\Sigma M_O = 400 \times 400 + 600 \sin 45^\circ \times 400 \text{ mm} = 329705.628 \text{ N}\cdot\text{mm} = 329.706 \text{ Nm}$$

$$\text{y-intercept} = \left| \frac{\Sigma M_O}{\Sigma F_x} \right| = \left| \frac{329.706}{824.264} \right| = 0.4 \text{ m} = 400 \text{ mm} \quad \text{Ans.}$$

Example 4.10 (a) Four forces act on a 700 mm \times 375 mm plate as shown in Figure 4.14. Find the resultant of these forces, and (b) locate the point where the line of action of the resultant intersects the edge AB of the plate. VTU (February 2004)

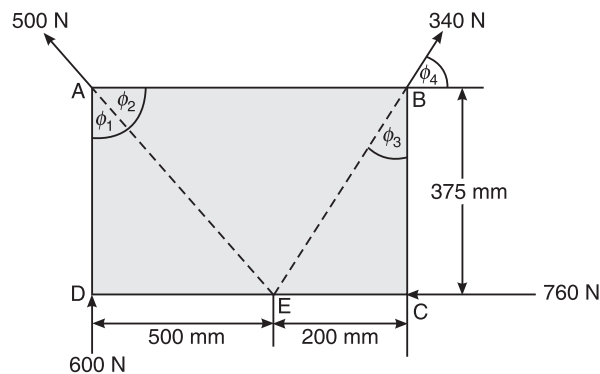

Figure 4.14 Example 4.10.

62 ELEMENTS OF CIVIL ENGINEERING AND ENGINEERING MECHANICS

Solution (a) $\tan \phi_1 = \frac{500}{375}$
 $\phi_1 = 53.13^\circ$
 $\phi_2 = 90^\circ - 53.13^\circ = 36.87^\circ$
 $\tan \phi_3 = \frac{200}{375} = 28.072^\circ$
 $\tan \phi_4 = 90^\circ - 28.072^\circ = 61.928^\circ$
 $R = \sqrt{\Sigma F_x^2 + \Sigma F_y^2}$
 $\Sigma F_x = -760 + 340 \cos 61.928^\circ - 500 \cos 36.87^\circ = -1000 \text{ N}$
 $\Sigma F_y = 600 + 500 \sin 36.87^\circ + 340 \sin 61.928^\circ = 1200 \text{ N}$
 $\therefore R = \sqrt{\Sigma F_x^2 + \Sigma F_y^2} = 1562.05 \text{ N}$ **Ans.**
 and $\theta_1 = \tan^{-1} \left(\frac{1200}{1000} \right) = 50.19^\circ$ **Ans.**

(b) $x\text{-intercept} = \left| \frac{\Sigma M_A}{\Sigma F_y} \right|$
 $\Sigma M_A = 760 \times 375 - 340 \sin 61.928^\circ \times 700 + 0 = 74999.048 \text{ N}\cdot\text{m}$
 $\therefore x\text{-intercept} = \left| \frac{74999.048}{1200} \right| = 62.499 \text{ mm}$

The resultant intersects the edge AB at a distance of 62.499 mm from point A. **Ans.**

Example 4.11 Determine the magnitude, direction of the resultant force for the force system shown in Figure 4.15. Locate the resultant force with respect to point D.

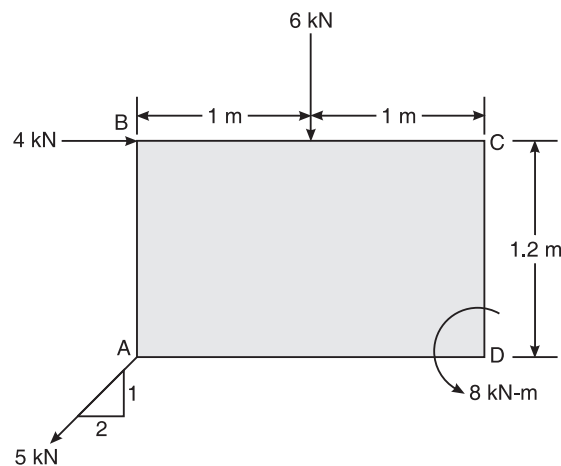

Figure 4.15 Example 4.11.

Solution Magnitude of resultant (R):

$$\Sigma F_x = 4 - 5 \cos 26.56^\circ = -0.472$$

$$\Sigma F_y = -6 - 5 \sin 26.56^\circ = -8.236$$

$$\therefore R = \sqrt{(-0.472)^2 + (-8.236)^2} = 8.249 \text{ kN} \quad \text{Ans.}$$

Direction of resultant (α):

$$\alpha = \tan^{-1} \left(\frac{\Sigma F_y}{\Sigma F_x} \right)$$

$$\therefore \alpha = \tan^{-1} \left(\frac{-8.236}{-0.472} \right) = 86.72^\circ. \quad \text{Ans.}$$

Position of resultant (d):

$$d = \left(\frac{\Sigma M_D}{R} \right)$$

$$\Sigma M_D = 4 \times 1.2 - 5 \sin 26.56^\circ \times 2 - 8 - 6 \times 1 = -13.671 \text{ kN-m}$$

$$d = \left| \frac{-13.671}{8.249} \right| = 1.657 \text{ m}$$

$$x\text{-intercept} = \left| \frac{\Sigma M_D}{\Sigma F_y} \right| = \left| \frac{-13.671}{-8.236} \right| = 1.659 \text{ m}$$

$$y\text{-intercept} = \left| \frac{\Sigma M_D}{\Sigma F_x} \right| = 28.964 \text{ m}$$

Ans.

Example 4.12 Determine the magnitude, direction and position of the resultant force with reference to the point A for the non-coplanar force system shown below in Figure 4.16.

VTU (July 2006)

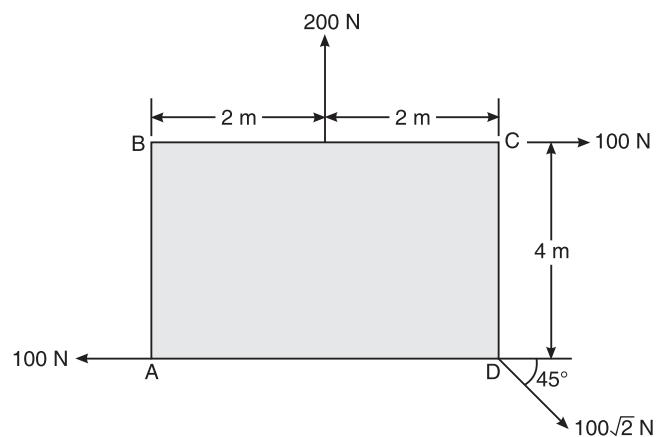

Figure 4.16 Example 4.12.

64 ELEMENTS OF CIVIL ENGINEERING AND ENGINEERING MECHANICS

Solution Magnitude of resultant (R):

$$R = \sqrt{\Sigma F_x^2 + \Sigma F_y^2}$$

$$\Sigma F_x = -100\sqrt{2} \cos 45^\circ + 100 - 100 = 100 \text{ N}$$

$$\Sigma F_y = -100\sqrt{2} \sin 45^\circ + 200 = 100 \text{ N}$$

$$\therefore R = \sqrt{100^2 + 100^2} = 141.421 \text{ N} \quad \text{Ans.}$$

Direction of resultant (θ) with reference to A:

$$\theta = \tan^{-1} \left(\frac{\Sigma F_y}{\Sigma F_x} \right)$$

$$\therefore \theta = \tan^{-1} \left(-\frac{100}{100} \right) = -45^\circ \quad \text{Ans.}$$

Position of resultant with reference to A:

$$\Sigma M_A = +100\sqrt{2} \sin 45^\circ \times 4 + 100 \times 4 - 208 \times 2 = 400 \text{ N}$$

$$x\text{-intercept} = \left| \frac{\Sigma M_A}{\Sigma F_y} \right| = \left| \frac{400}{100} \right| = 4 \text{ m}$$

$$y\text{-intercept} = \left| \frac{\Sigma M_A}{\Sigma F_x} \right| = \left| \frac{400}{100} \right| = 4 \text{ m}$$

$$d = \left| \frac{\Sigma M_A}{R} \right| = \left| \frac{400}{141.421} \right| = 2.828 \text{ m}$$

Ans.

Example 4.13 Find the magnitude and direction and distance of the resultant from the point 'A' for the system of forces shown in Figure 4.17.

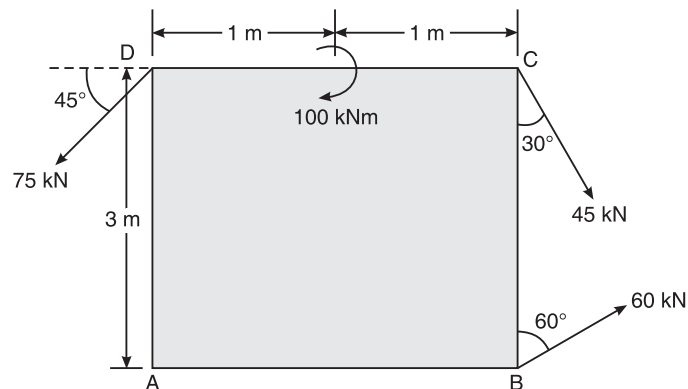

Figure 4.17 Example 4.13.

Solution Magnitude of resultant (R):

$$R = \sqrt{\Sigma F_x^2 + \Sigma F_y^2}$$

$$\Sigma F_x = 45^\circ \sin 30^\circ + 60^\circ \sin 60^\circ - 75^\circ \cos 45^\circ = 21.428$$

$$\Sigma F_y = -45^\circ \cos 30^\circ + 60^\circ \cos 60^\circ - 75^\circ \sin 45^\circ = -62.004$$

$$\therefore R = \sqrt{(21.428)^2 + (-62.004)^2} = 65.602 \text{ kN} \quad \text{Ans.}$$

Direction of resultant (θ):

$$\theta = \tan^{-1} \left(\frac{\Sigma F_y}{\Sigma F_x} \right)$$

$$\therefore \theta = \tan^{-1} \left(\frac{-62.004}{21.428} \right) = 70.93^\circ \quad \text{Ans.}$$

Position of resultant with respect to point A (d):

$$\begin{aligned} \Sigma M_A &= -75 \cos 45^\circ \times 3 - 60 \cos 60^\circ \times 2 + 45 \sin 30^\circ \times 3 + 45 \cos 30^\circ \times 2 + 100 \\ &= 26.343 \text{ kN-m} \end{aligned}$$

$$x\text{-intercept} = \left| \frac{\Sigma M_A}{\Sigma F_y} \right| = \left| \frac{26.343}{65.602} \right| = 0.425 \text{ m}$$

$$y\text{-intercept} = \left| \frac{\Sigma M_A}{\Sigma F_x} \right| = \left| \frac{26.343}{21.248} \right| = 1.239 \text{ m}$$

Ans.

Example 4.14 The force 390 N shown in Figure 4.18 is the resultant of four forces. Out of them, three are shown in the figure. Find the missing force and its position.

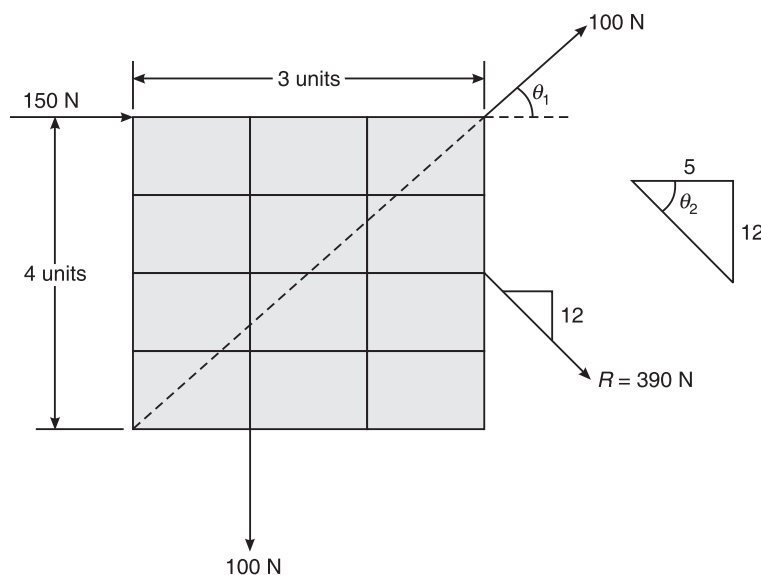

Figure 4.18 Example 4.14.

66 ELEMENTS OF CIVIL ENGINEERING AND ENGINEERING MECHANICS**Solution** Assume missing force = F

Using the conditions of equilibrium, we have

$$\Sigma F_x = 0$$

$$\text{or } 390 \cos 67.38^\circ = 150 + 100 \cos 53.13^\circ + F \cos \theta$$

$$\text{or } F \cos \theta = -60 \quad \text{(i)}$$

$$\text{Also, } \Sigma F_y = 0$$

$$\text{or } -390 \sin 67.38^\circ = 100 \sin 53.13^\circ - 100 + F \sin 60^\circ$$

$$\text{or } F \sin \theta = -340 \quad \text{(ii)}$$

Dividing (ii) by (i), we get

$$\frac{F \sin \theta}{F \cos \theta} = \frac{-340}{-60}$$

$$\therefore \tan \theta = 5.667 \quad \text{or } \theta = 79.99^\circ$$

Substituting to value of θ in (i)

$$F = \frac{-60}{\cos 79.99^\circ} = -345.184 \text{ N} \quad \text{Ans}$$

EXERCISE PROBLEMS

1. Find the resultant of the force shown in Figure 4.19.

[Ans.: $R = 115.563 \text{ kN}$, $\theta = 36.90^\circ$, $X = 10.576$, $d = 6.351$]

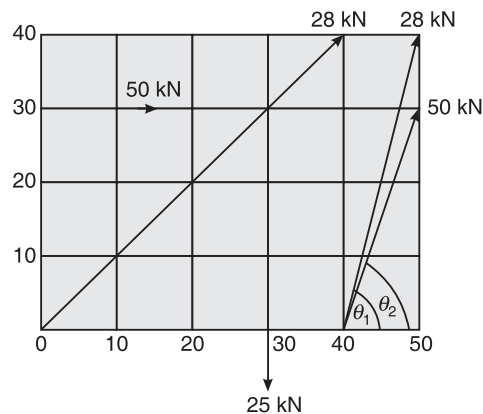

Figure 4.19

2. Find the magnitude, direction and position of the resultant of the force system, shown in Figure 4.20, with respect to point A. [Ans.: $R = 25 \text{ kN}$ $\theta = -45^\circ$ $x = 62.1 \text{ cm}$]

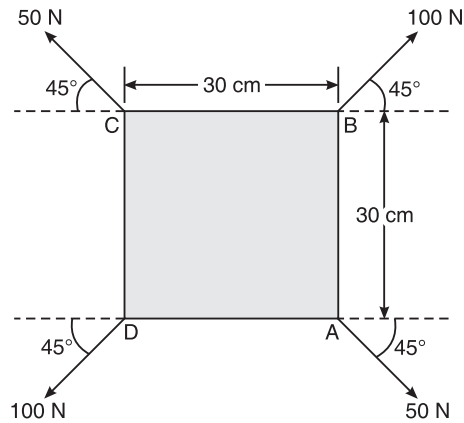

Figure 4.20

3. Four forces are acting on $28\text{ cm} \times 15\text{ cm}$ plate as shown in Figure 4.21. Find the resultant of these forces. Locate the two points where the line of action of the resultant intersects the edge of the plate.

[Ans.: $R = 390.49\text{ N}$, $\theta = -39.8^\circ$, $x = 12\text{ cm}$ (right of C), $y = 10\text{ cm}$ (above C)]

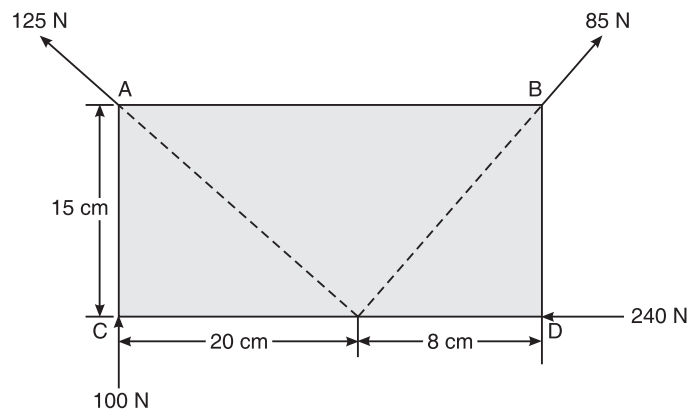

Figure 4.21

4. Determine:
- (i) The resultant of the forces.
 - (ii) The sum of moments of the forces about the point A, the 10 kN force acts parallel to AB as shown in Figure 4.22.

[Ans.: $R = 17.479\text{ kN}$, $\theta = 8.52^\circ$, $\Sigma M_A = 26.799\text{ kN-m.}$]

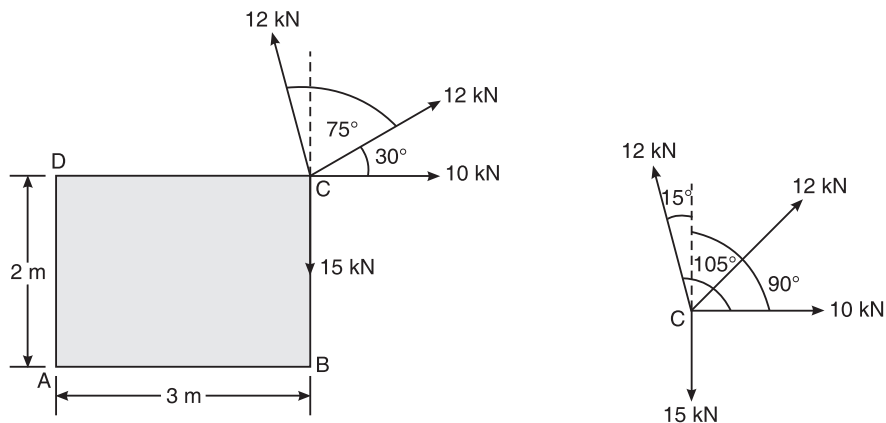

Figure 4.22

5. Three forces 60 N, 80 N and 130 N act at the vertices of a triangle ABC as shown in Figure 4.23. $AB = BC = CA = 40$ cm. Find the resultant of the system. Locate the point D on BC where the resultant intersects BC. Find the distance of D from C.

[Ans.: $R = 62.45$ N, $\theta = -43.90$, $x = 104$ cm
i.e. the point D is at a distance of 104 cm from C to the right.]

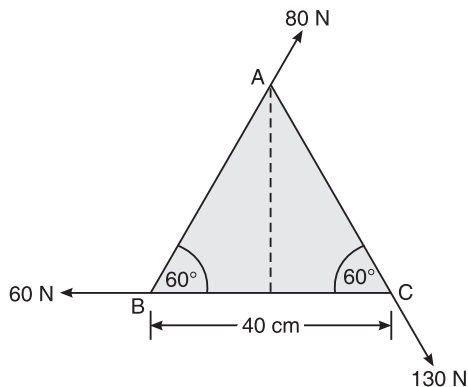

Figure 4.23

6. Find the resultant of the force system shown in Figure 4.24 and locate the position of line of action of resultant along x -axis with origin at O. Also, find the magnitude and sense of a single vertical force to be applied at A, so that the resultant of entire system passes through B and find the resultant.

[Ans.: $x = 701.5$, $R = 22.36$ N, $\theta = 63.435^\circ$, $P = 90$ kN, $R_1 = 111.8$ kN.]

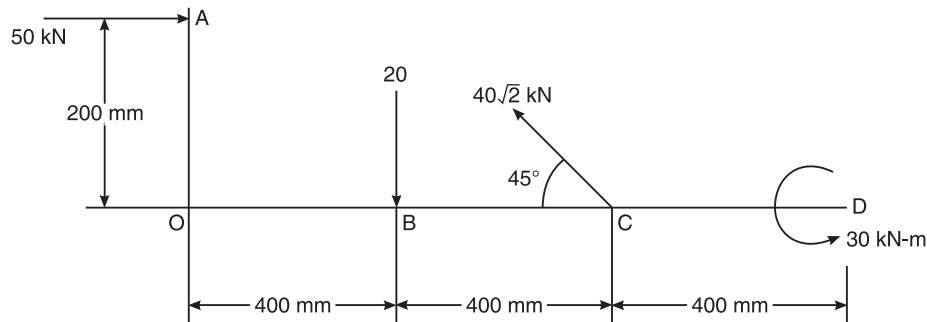

Figure 4.24

Hint: First find the resultant and then apply a vertical force of P at A (assume down or up), such that the x -intercept is 400 cm.

7. Three forces act on a vertical pole as shown in Figure 4.25. Find the resultant of the three forces. Locate the point where the resultant cuts the pole.

[Ans.: $R = 5.38$ kN, $\theta = 48.01^\circ$]

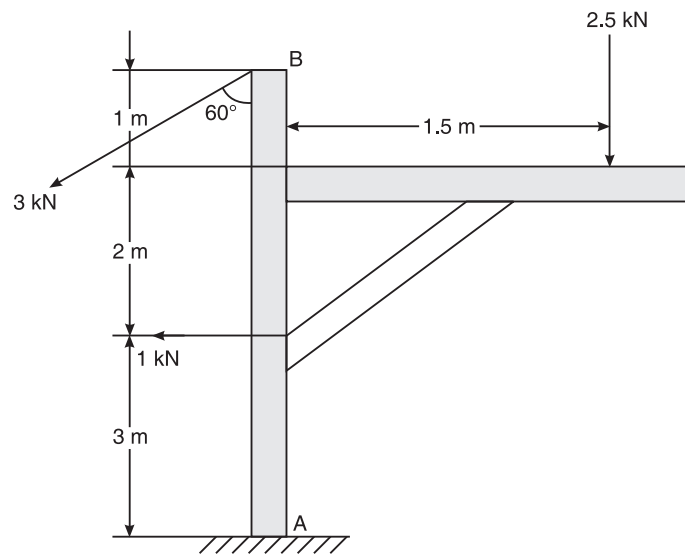

Figure 4.25

Hint: 4.12 m (above A)

8. The three forces and a couple of moment $M = 6$ N-m are applied to an angle bracket as shown in Figure 4.26.

- (a) Find the resultant of the system of forces
 (b) Locate the points where the line of action of the resultant intersects lines AB and BC

[Ans.: $R = 135.96$ N, $\theta = 28.04^\circ$, x -intercept = 0.281 m, y -intercept = 0.150 m (below B)]

70 ELEMENTS OF CIVIL ENGINEERING AND ENGINEERING MECHANICS

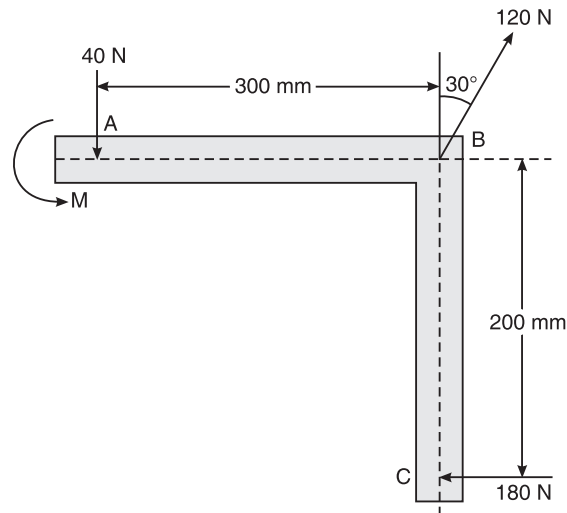

Figure 4.26

9. Various forces to be considered for the stability analysis of a dam are shown in Figure 4.27. The dam is safe if the resultant force passes through middle-third of base.

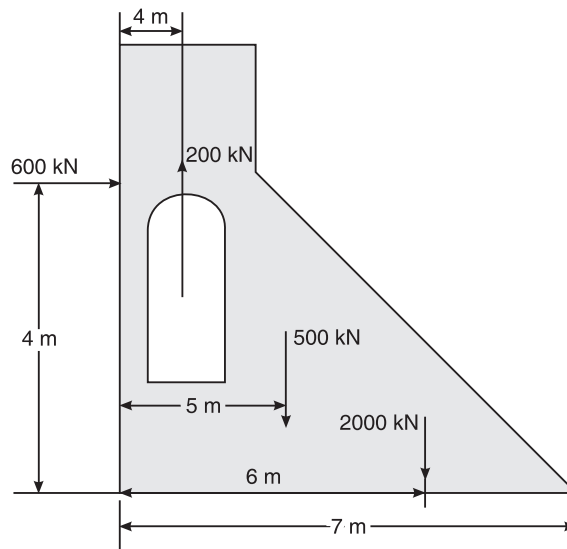

Figure 4.27

Hint: Dam is safe if the x -intercept is between $1/3$ rd and $2/3$ rd of base.

10. Forces acting on 1 m length of a dam are shown in Figure 4.28. Neglecting the weight of the dam, determine the resultant force acting on the dam. Find the point of intersection of the resultant with the base of the dam. [Ans.: $x = 2.91$ m from the right.]

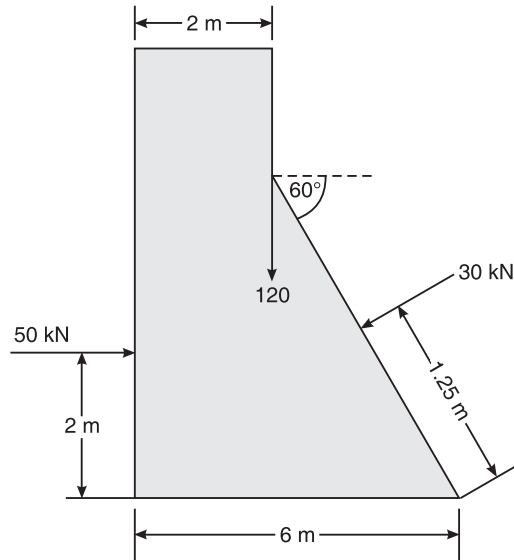

Figure 4.28

EQUILIBRIUM OF COPLANAR CONCURRENT FORCE SYSTEM

EQUILIBRIUM

When a stationary body is subjected to external forces and if the body remains in the state of rest under the action of forces, it is said to be in equilibrium.

Principle of equilibrium

According to this principle, 'A body is said to be in equilibrium if the algebraic sum of all forces acting on the body is zero, and also if the algebraic sum of moments of forces about any fixed point is zero,

i.e.

$$\Sigma F = 0, \Sigma F_x = 0, \Sigma F_y = 0, \Sigma M = 0$$

A body is said to be in equilibrium if there is no translation and no rotation of the body under the application of external forces.

Conditions of equilibrium for different force systems

1. Coplanar concurrent force system

$$\Sigma F_x = 0, \Sigma F_y = 0 \quad (\text{moment is already zero}). \text{ See Figure 5.1.}$$

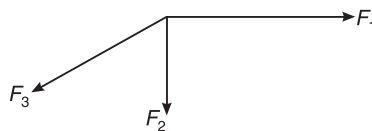

Figure 5.1 Coplanar concurrent force system.

2. Coplanar non-concurrent force system

$$\Sigma F_x = 0, \Sigma F_y = 0, \Sigma M = 0. \text{ See Figure 5.2.}$$

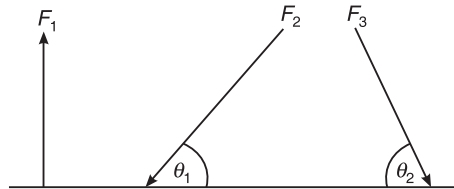

Figure 5.2 Coplanar non-concurrent force system.

3. Parallel force system

$$\Sigma F = 0, \Sigma M = 0$$

4. Non-coplanar force system

$$\Sigma F_x = 0, \Sigma F_y = 0, \Sigma F_z = 0, \Sigma M = 0$$

Equilibrant

Sometimes the resultant of the force system is not equal to zero. That means the body is not in equilibrium. The force which is required to keep the body in equilibrium, is known as equilibrant.

Lami's theorem

This theorem states that 'if three forces acting at a point are in equilibrium, then each force is directly proportional to the sine of angle between the other two forces'.

Let P, Q, R be the three forces acting at a point O and let α, β, γ be the angles between R and Q, P and R, P and Q respectively. See figure 5.3.

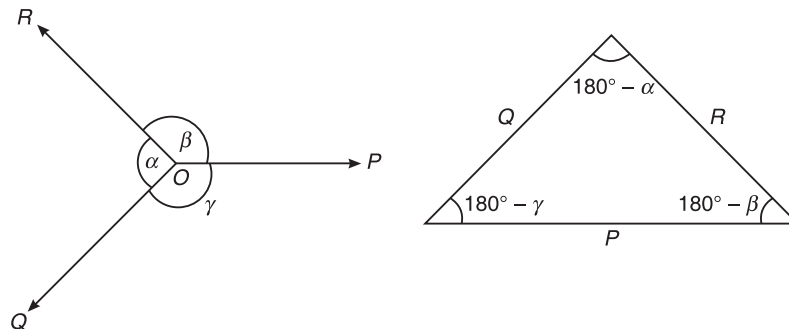

Figure 5.3 Lami's theorem.

Using Lami's theorem, we have

$$\frac{P}{\sin(180^\circ - \alpha)} = \frac{Q}{\sin(180^\circ - \beta)} = \frac{R}{\sin(180^\circ - \gamma)}$$

$$\therefore \frac{P}{\sin \alpha} = \frac{Q}{\sin \beta} = \frac{R}{\sin \gamma}$$

It is possible to apply the Lami's theorem, if only three forces are acting on a particle or at a point.

74 ELEMENTS OF CIVIL ENGINEERING AND ENGINEERING MECHANICS

Free-body diagram (FBD)

A free-body diagram is the diagram which represents the various forces acting on the body.

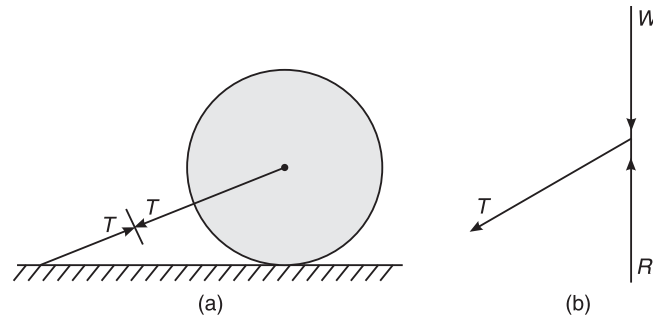

Figure 5.4 Spherical ball (on a horizontal plane) with free-body diagram.

Let us consider a spherical ball of mass m , placed on a horizontal plane and tied to the plane by a string as shown in Figure 5.4(a).

Figure 5.4(b) shows the free-body diagram of the spherical ball subjected to various forces like:

- (i) Self weight, W , always acting vertically downwards.
- (ii) Normal reaction, R , always acting perpendicular to the plane under consideration.
- (iii) Tension T in the string.

In Figure 5.5, a spherical ball supported by a string and resting against a wall, is shown together with its free-body diagram.

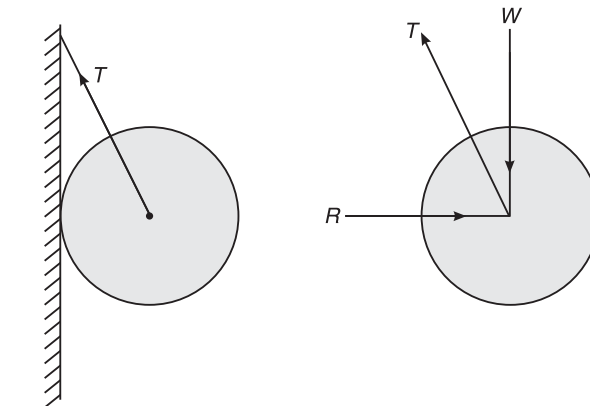

Figure 5.5 Spherical ball (resting against a wall) with free-body diagram.

PROBLEMS ON EQUILIBRIUM OF COPLANAR CONCURRENT FORCE SYSTEM

Tips to Solve the Problems

1. In the coplanar concurrent force system, two conditions of equilibrium can be applied, namely

$$\Sigma F_x = 0 \quad \text{and} \quad \Sigma F_y = 0$$

2. Analyse the given problem by applying the above conditions of equilibrium or by applying the Lami's theorem.
3. Lami's theorem can be applied if only three forces are acting at a point.

i.e.

$$\frac{P}{\sin \alpha} = \frac{Q}{\sin \beta} = \frac{R}{\sin \gamma}$$

Example 5.1 Determine the magnitude and direction of force P , which keeps the concurrent system of Figure 5.6 in equilibrium. VTU (August 2003)

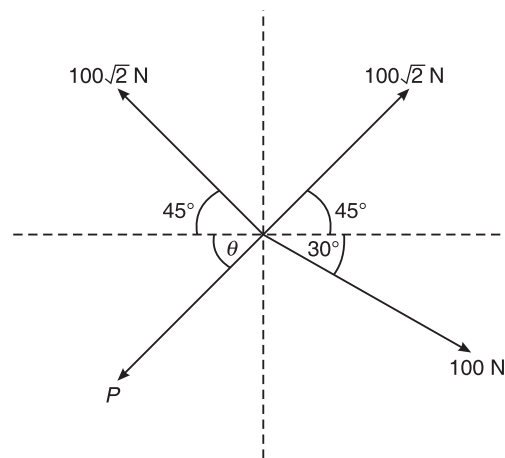

Figure 5.6 Example 5.1.

Solution Apply two conditions of equilibrium to calculate the magnitude and direction of the unknown force.

$$\Sigma F_x = 0$$

$$\text{or} \quad -P \cos \theta - 100\sqrt{2} \cos 45^\circ + 100\sqrt{2} \cos 45^\circ + 100 \cos 30^\circ = 0$$

$$\text{or} \quad P \cos \theta = 100 \cos 30^\circ$$

$$\text{or} \quad P \cos \theta = 86.603 \quad \text{(i)}$$

$$\Sigma F_y = 0$$

$$\text{or} \quad -P \sin \theta + 100\sqrt{2} \sin 45^\circ + 100\sqrt{2} \sin 45^\circ - 100 \sin 30^\circ = 0$$

$$\text{or} \quad P \sin \theta = 150 \quad \text{(ii)}$$

$$\therefore \frac{P \sin \theta}{P \cos \theta} = \frac{150}{86.603} \quad \text{(Dividing (ii) by (i))}$$

$$\text{or} \quad \tan \theta = \frac{150}{86.603}$$

$$\text{or} \quad \theta = 60^\circ \quad \text{Ans.}$$

$$\therefore P = \frac{150}{\sin 60^\circ} = \frac{150 \times 2}{\sqrt{3}} = 173.2 \text{ N} \quad \text{(using Eq. (ii))} \quad \text{Ans.}$$

76 ELEMENTS OF CIVIL ENGINEERING AND ENGINEERING MECHANICS

Example 5.2 A crate of mass 200 kg is to be supported by a rope and pulley arrangement as shown in Figure 5.7(a). Determine the minimum required magnitude of force F . Also, find the direction of force F .

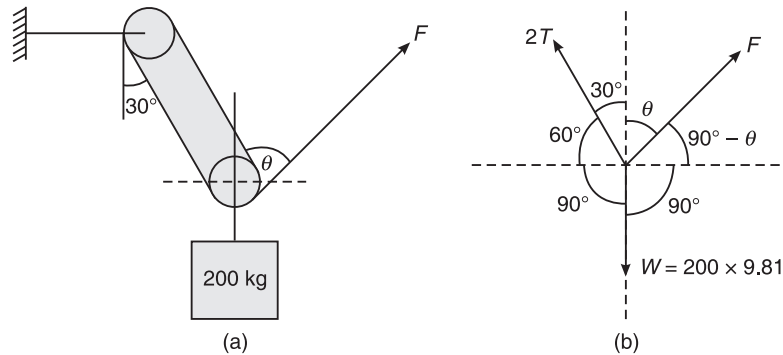

Figure 5.7 Example 5.2.

Solution

$$W = m \times g = 200 \times 9.81 = 1962 \text{ N}$$

Applying Lami's theorem (Figure 5.7(b)), we have

$$\frac{W}{\sin(30^\circ + \theta)} = \frac{F}{\sin(90^\circ + 60^\circ)} = \frac{2T}{\sin(180^\circ - \theta)}$$

or

$$F = \frac{1962 \times \sin 150^\circ}{\sin(30^\circ + \theta)} = 981 \text{ N}$$

Ans.

because F is minimum when $\sin(30^\circ + \theta)$ is maximum. The maximum value of $\sin(30^\circ + \theta) = \sin 90^\circ$ i.e.

$$30^\circ + \theta = 90^\circ$$

or

$$\theta = 60^\circ$$

Ans.

Example 5.3 A 3 kN crate is supported by the rope and pulley arrangement shown in Figure 5.8(a). Determine the magnitude and the direction of the minimum force F that should be exerted at the free end of the rope. *VTU (February 2004)*

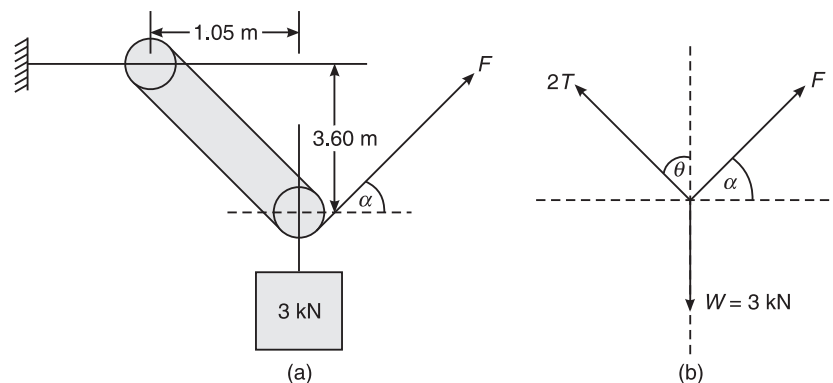

Figure 5.8 Example 5.3.

Solution $\theta = \tan^{-1} \left(\frac{1.05}{3.6} \right) = 16.26^\circ$ **Ans.**

According to Lami's theorem (Figure 5.8(b)), we have

$$\frac{F}{\sin(180^\circ - \theta)} = \frac{2T}{\sin(90^\circ + \alpha)} = \frac{W}{\sin(\theta + 90^\circ - \alpha)}$$

or $\frac{F}{\sin \theta} = \frac{3}{\sin(\theta + 90^\circ - \alpha)}$

or $\frac{F}{\sin 16.26^\circ} = \frac{3}{\sin(\theta + 90^\circ - \alpha)}$

Now $\sin(\theta + 90^\circ - \alpha)$ is maximum when

$$\sin(\theta + 90^\circ - \alpha) = \sin 90^\circ$$

i.e. $\theta = \alpha$

or $\frac{F}{\sin 16.26^\circ} = 3$

$\therefore F = 3 \times \sin 16.26^\circ = 0.839 \text{ kN}$ **Ans.**

Example 5.4 Determine the forces induced in the members AC and BC of the structure shown in Figure 5.9(a). Its free-body diagram is shown in Figure 5.9(b).

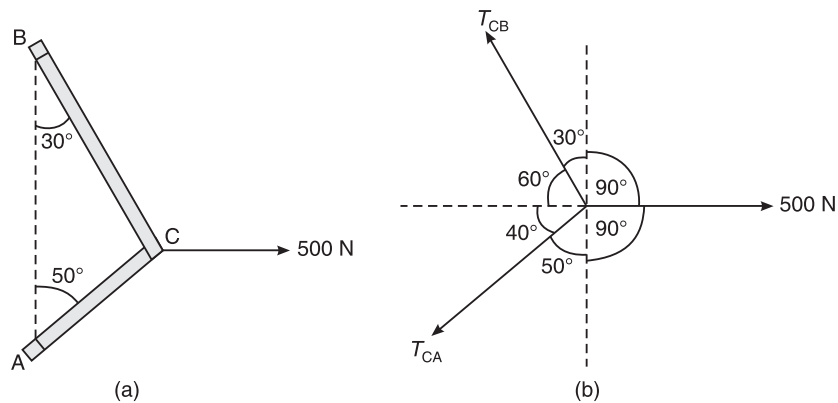

Figure 5.9 Example 5.4.

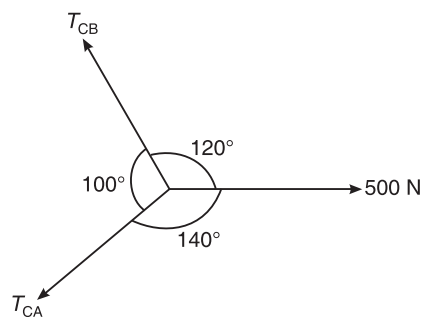

Figure 5.10 Example 5.4: Free-body diagram.

78 ELEMENTS OF CIVIL ENGINEERING AND ENGINEERING MECHANICS

Solution Using Lami's theorem (Figure 5.10), we have

$$\frac{T_{CA}}{\sin 120^\circ} = \frac{T_{CB}}{\sin 140^\circ} = \frac{500}{\sin 100^\circ}$$

or
$$\frac{T_{CA}}{\sin 120^\circ} = \frac{500}{\sin 100^\circ}$$

$\therefore T_{CA} = 439.695 \text{ N}$ **Ans.**

Again,
$$\frac{T_{CA}}{\sin 120^\circ} = \frac{T_{CB}}{\sin 140^\circ} = \frac{500}{\sin 100^\circ}$$

or
$$\frac{T_{CB}}{\sin 140^\circ} = \frac{500}{\sin 100^\circ}$$

or
$$T_{CB} = \frac{500}{\sin 100^\circ} \times \sin 140^\circ$$

$\therefore T_{CB} = 326.352 \text{ N}$ **Ans.**

Example 5.5 Two cables are connected at A and B as shown in Figure 5.11(a). A force of 30 kN is applied at C. Determine the forces in the cables CA and CB.

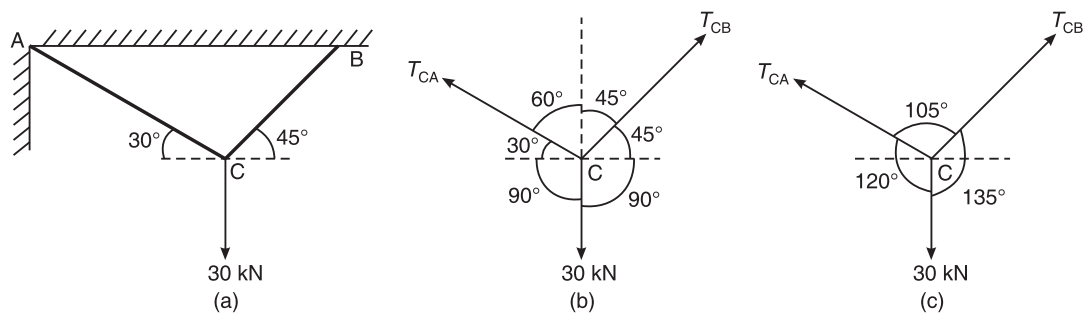

Figure 5.11 Example 5.5.

Solution Using Lami's theorem (Figure 5.11(b) and (c)), we have

$$\frac{T_{CA}}{\sin 135^\circ} = \frac{T_{CB}}{\sin 120^\circ} = \frac{30}{\sin 105^\circ}$$

or
$$T_{CA} = \frac{30}{\sin 105^\circ} \times \sin 135^\circ$$

$$= 21.961 \text{ kN}$$
 Ans.

Again,
$$\frac{T_{CB}}{\sin 120^\circ} = \frac{30}{\sin 105^\circ}$$

or
$$T_{CB} = \frac{30}{\sin 105^\circ} \times \sin 120^\circ$$

$$= 26.897 \text{ kN}$$
 Ans.

Example 5.6 Find the value of W , which is required to maintain equilibrium configuration as shown in Figure 5.12(a). Its free-body diagram is shown in Figure 5.12(b).

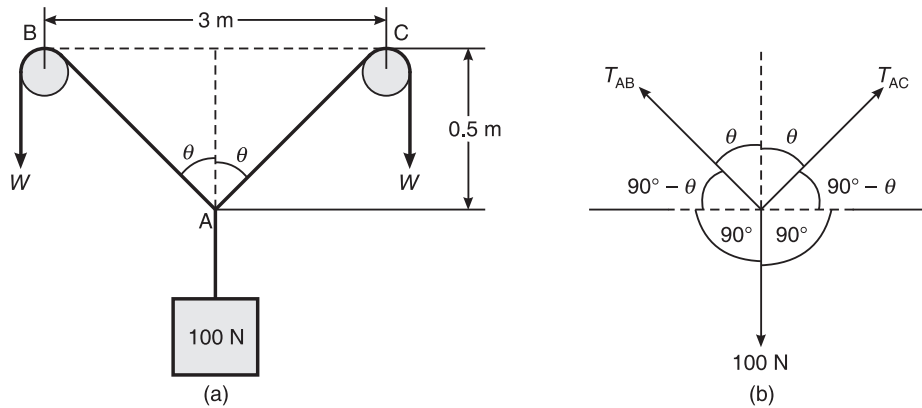

Figure 5.12 Example 5.6.

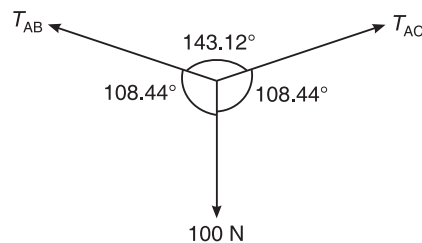

Figure 5.13 Example 5.6: Free-body diagram.

Solution

$$\tan \theta = \frac{1.5}{0.5} = 3$$

or

$$\theta = \tan^{-1}(3) = 71.56^\circ$$

Now,

$$\frac{100}{\sin 143.12^\circ} = \frac{T_{AB}}{\sin 108.44^\circ} = \frac{T_{AC}}{\sin 108.44^\circ}$$

(Applying Lami's theorem to Figure 5.13)

or

$$T_{AB} = T_{AC} = \frac{100 \times \sin 108.44^\circ}{\sin 143.12^\circ} = 158.113 \text{ N}$$

Weight acting on the cable = tension in the cable

i.e.

$$W = 158.113 \text{ N}$$

Ans.

Example 5.7 Figure 5.14(a) shows a rope supporting two loads W and P . If BC is horizontal and $W = 600 \text{ N}$, determine the load P . Also, find the tensile forces developed in the different segments of the rope.

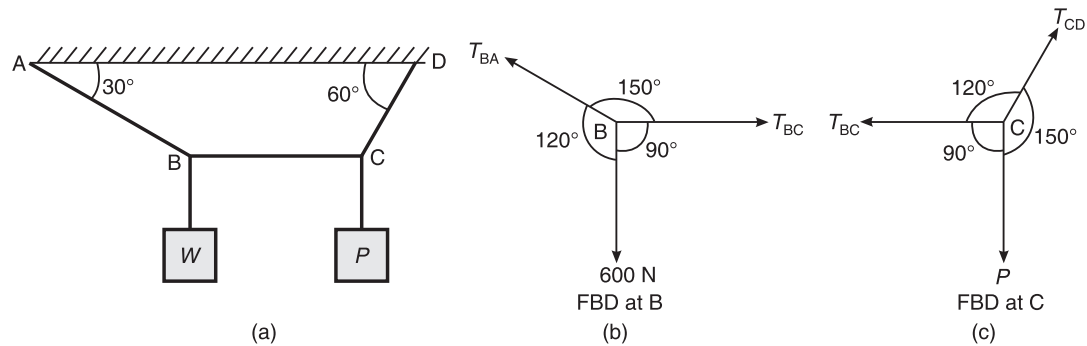

Figure 5.14 Example 5.7.

Solution Considering the FBD at B and applying Lami's theorem (Figure 5.14(b)),

$$\frac{T_{BA}}{\sin 90^\circ} = \frac{T_{CB}}{\sin 120^\circ} = \frac{600}{\sin 150^\circ}$$

or

$$\frac{T_{CB}}{\sin 120^\circ} = \frac{600}{\sin 150^\circ}$$

\therefore

$$T_{BC} = \frac{600}{\sin 150^\circ} \times \sin 120^\circ$$

$$= 1039.230 \text{ N}$$

Ans.

Considering the FBD at C and applying the Lami's theorem (Figure 5.14(c)),

$$\frac{T_{CD}}{\sin 90^\circ} = \frac{1039.23}{\sin 150^\circ} = \frac{P}{\sin 120^\circ}$$

or

$$P = \frac{1039.23}{\sin 150^\circ} \times \sin 120^\circ$$

$$= 1800 \text{ N}$$

Ans.

$$= 1200 \text{ N}$$

Ans.

$$T_{CD} = \frac{1039.23}{\sin 150^\circ}$$

$$= 2078.46 \text{ N}$$

Ans.

Example 5.8 A string ABCD attached to two fixed points A and D has two equal weights 500 N attached to it at B and C (Figure 5.15). The weights rest with portions AB and CD inclined at angles of 30° and 60° respectively with the vertical. Find the tensions in the portions AB, BC, and CD of the string. The inclination of BC with vertical is 120° .

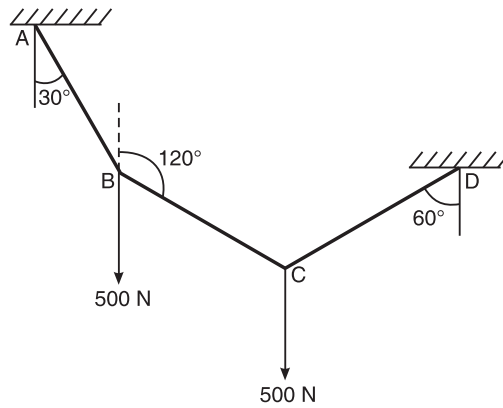

Figure 5.15 Example 5.8.

Solution Considering the FBD at B and applying the Lami's theorem (Figure 5.16),

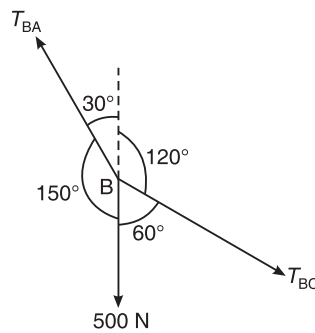

Figure 5.16 FBD at B.

$$\frac{T_{BA}}{\sin 60^\circ} = \frac{T_{BC}}{\sin 150^\circ} = \frac{500}{\sin 150^\circ}$$

or

$$T_{BA} = 866.03 \text{ N}$$

and

$$\frac{T_{BA}}{\sin 60^\circ} = \frac{500}{\sin 150^\circ}$$

∴

$$T_{BA} = 866.03 \text{ N}$$

Ans.

Considering the FBD at C and applying the Lami's theorem (Figure 5.17),

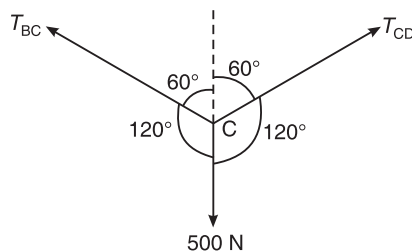

Figure 5.17 FBD at C.

$$\frac{T_{BC}}{\sin 120^\circ} = \frac{T_{CD}}{\sin 120^\circ} = \frac{500}{\sin 120^\circ}$$

∴

$$T_{CD} = 500 \text{ N}$$

Ans.

Example 5.9 The system of connected flexible cables shown in Figure 5.18 is supporting 2 loads of 400 N and 500 N at points B and D, respectively. Determine the tensions in the various segments of the cable.

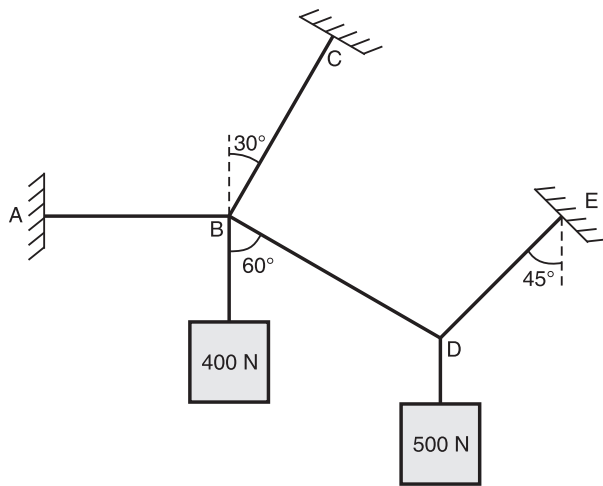

Figure 5.18 Example 5.9.

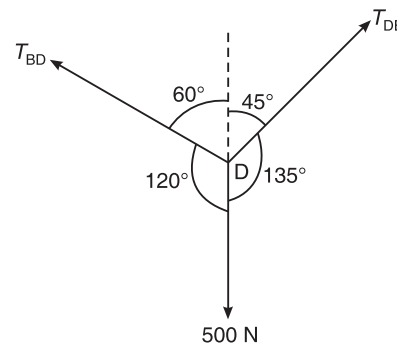

Figure 5.19 FBD at D.

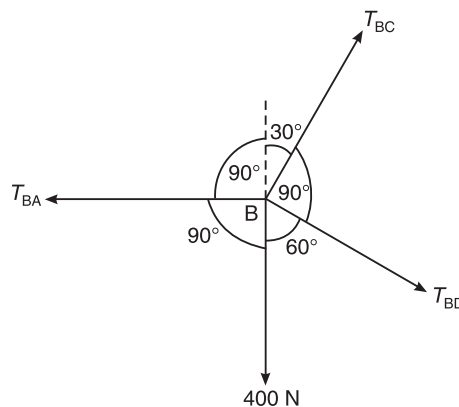

Figure 5.20 FBD at B.

Solution At D (Figure 5.19):

$$\frac{500}{\sin 105^\circ} = \frac{T_{DE}}{\sin 120^\circ} = \frac{T_{BD}}{\sin 135^\circ}$$

or

$$\begin{aligned} T_{BD} &= \frac{500}{\sin 105^\circ} \times \sin 135^\circ \\ &= 366.025 \text{ N} \end{aligned}$$

Ans.

and

$$T_{DE} = \frac{500}{\sin 105^\circ} \times \sin 120^\circ$$

$$= 448.287 \text{ N} \quad \text{Ans.}$$

At B (Figure 5.20):

$$\Sigma F_x = 0$$

$$\Sigma F_y = 0$$

In this case, it is not possible to apply Lami's theorem, there being 4 forces.

$$\Sigma F_y = 0$$

or

$$-400 + T_{BC} \sin 60^\circ - T_{BD} \sin 30^\circ = 0$$

\therefore

$$T_{BC} = \frac{400 + 366.025 \sin 30^\circ}{\sin 60^\circ}$$

$$= 673.204 \text{ N} \quad \text{Ans.}$$

$$\Sigma F_x = 0$$

or

$$-T_{BA} + T_{BC} \cos 60^\circ + T_{BD} \cos 30^\circ = 0$$

\therefore

$$T_{BA} = 673.204 \cos 60^\circ + 366.025 \cos 30^\circ$$

$$= 653.588 \text{ N} \quad \text{Ans.}$$

Example 5.10 Compute the tensions in the strings AB, BC and CD as shown in Figure 5.21.

VTU (January 2007)

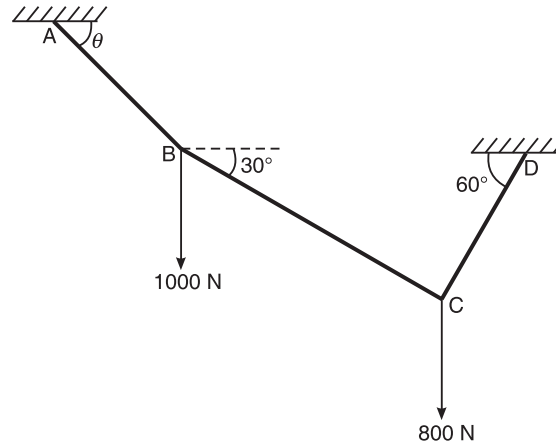

Figure 5.21 Example 5.10.

Solution Consider FBD at C (Figure 5.22).

Using Lami's theorem, we have

$$\frac{T_{CD}}{\sin 120^\circ} = \frac{T_{BC}}{\sin 150^\circ} = \frac{800}{\sin 90^\circ}$$

\therefore $T_{BC} = 400 \text{ N}$ Ans.

and $T_{CD} = 692.82 \text{ N}$ Ans.

84 ELEMENTS OF CIVIL ENGINEERING AND ENGINEERING MECHANICS

Consider FBD at B (Figure 5.23), using conditions of equilibrium, we have

$$\Sigma F_x = 0$$

or $-T_{AB} \cos \theta + 400 \cos 30^\circ = 0$

or $T_{AB} \cos \theta = 346.41$ (i)

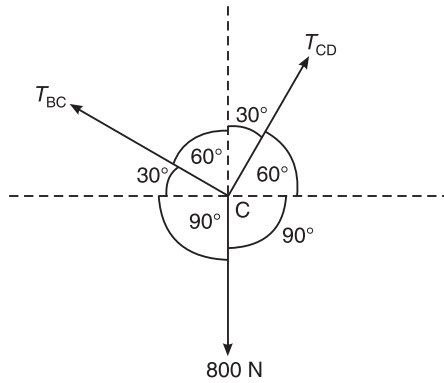

Figure 5.22 FBD at C.

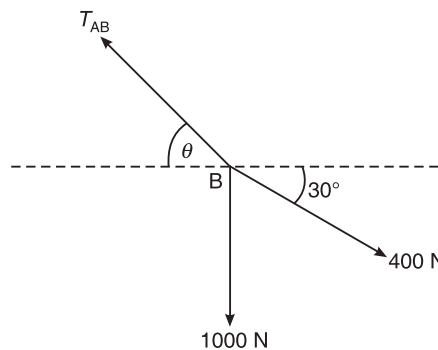

Figure 5.23 FBD at B.

$$\Sigma F_y = 0$$

or $T_{AB} \sin \theta - 400 \sin 30^\circ - 1000 = 0$

or $T_{AB} \sin \theta = 1200$ (ii)

Dividing Eq. (ii) by (i),

$$\frac{T_{AB} \sin \theta}{T_{AB} \cos \theta} = \frac{1200}{346.41}$$

or $\theta = 73.90^\circ$

Substituting the value of θ in (i), we get

$$T_{AB} = 1249.158 \text{ N} \quad \text{Ans.}$$

Example 5.11 Determine the tension in different parts of the string shown in Figure 5.24. Also, find the value of W_1 and W_2 , if the portion BC is horizontal.

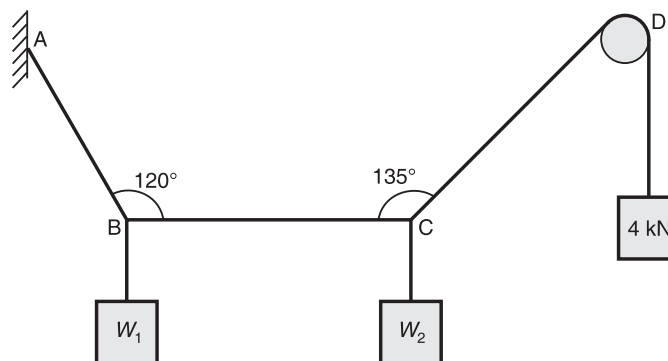

Figure 5.24 Example 5.11.

Solution Consider FBD at C (Figure 5.25).

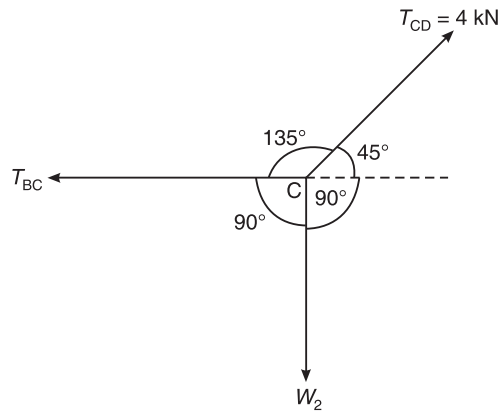

Figure 5.25 FBD at C.

Using Lami's theorem, we have

$$\frac{T_{BC}}{\sin 135^\circ} = \frac{W_2}{\sin 135^\circ} = \frac{4}{\sin 90^\circ}$$

\therefore
and

$$T_{BC} = 2.828 \text{ kN}$$

Ans.

$$W_2 = 2.828 \text{ kN}$$

Ans.

Consider FBD at B (Figure 5.26).

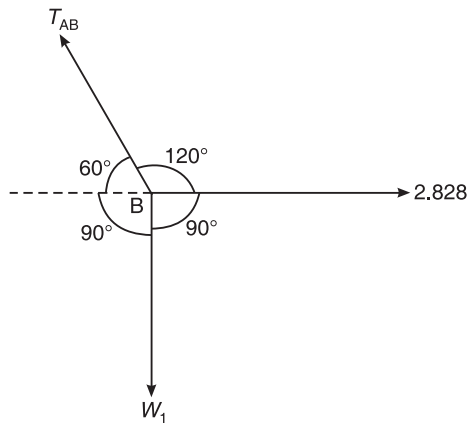

Figure 5.26 FBD at B.

Using Lami's theorem, we have

$$\frac{T_{AB}}{\sin 90^\circ} = \frac{W_1}{\sin 120^\circ} = \frac{2.828}{\sin 150^\circ}$$

Solving, we get

$$T_{AB} = 5.656 \text{ kN}$$

Ans.

and

$$W_1 = 4.898 \text{ kN}$$

Ans.

86 ELEMENTS OF CIVIL ENGINEERING AND ENGINEERING MECHANICS

Example 5.12 A sphere weighing 100 N is fitted in a right-angled notch as shown in Figure 5.27. If all contact surfaces are smooth, determine the reaction at contact surfaces:

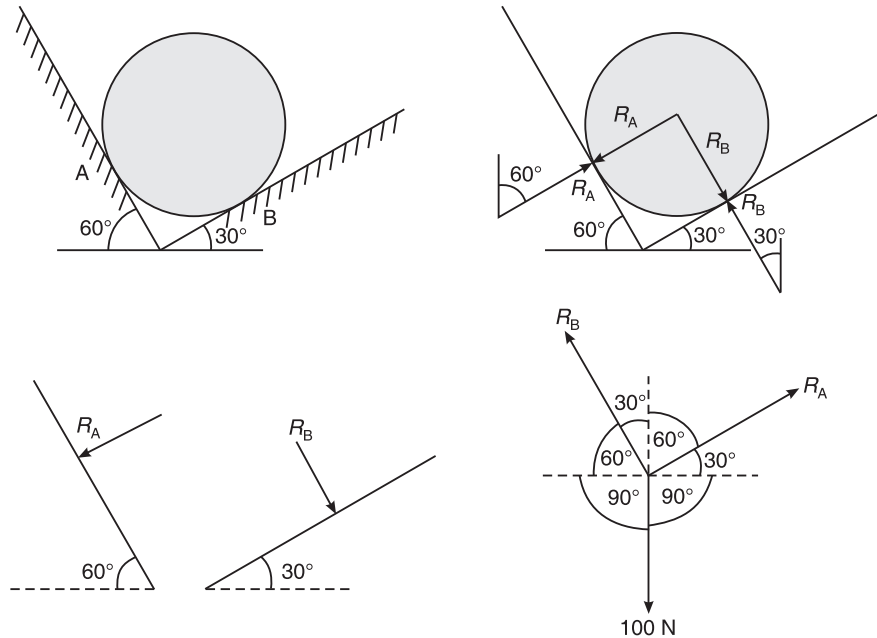

Figure 5.27 Example 5.12.

Solution At contact points, reaction is developed which is perpendicular to each plane.

Suppose the two planes are perpendicular to each other, if one plane makes an angle of θ with the horizontal, the perpendicular plane makes an angle θ with the vertical.

Applying Lami's theorem, we have

$$\frac{R_B}{\sin 120^\circ} = \frac{R_A}{\sin 150^\circ} = \frac{100}{\sin 90^\circ}$$

or
$$R_B = \frac{\sin 120^\circ \times 100}{\sin 90^\circ}$$

$$R_B = 86.602 \text{ N} \quad \text{Ans.}$$

and
$$R_A = \frac{\sin 150^\circ \times 100}{\sin 90^\circ} = 50 \text{ N} \quad \text{Ans.}$$

Example 5.13 Find the reaction from the inclined plane and tension in the string for the arrangement in Figure 5.28. Take the weight of the ball = 450 N.

Solution
$$\frac{T}{\sin 140^\circ} = \frac{R}{\sin 160^\circ} = \frac{450}{\sin 60^\circ}$$

$$\therefore T = \frac{\sin 140^\circ \times 450}{\sin 60^\circ} = 334.002 \text{ N} \quad \text{Ans.}$$

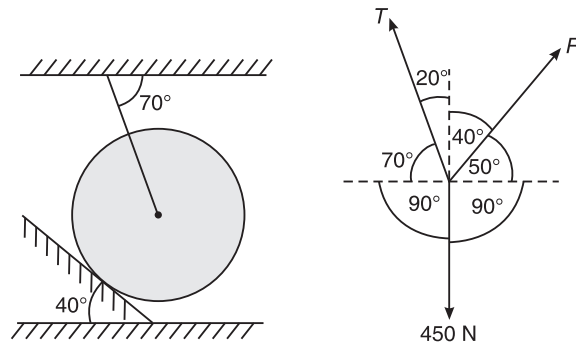

Figure 5.28 Example 5.13.

Also,

$$\frac{R}{\sin 160^\circ} = \frac{450}{\sin 60^\circ}$$

$$\therefore R = \frac{\sin 160^\circ \times 450}{\sin 60^\circ} = 177.719 \text{ N} \quad \text{Ans.}$$

Example 5.14 A horizontal shaft with inner clearance of 1000 mm carries two spheres of radius 350 mm and 250 mm as shown in Figure 5.29. The weights are 600 N and 500 N respectively. Find the reactions at all the points of contact.

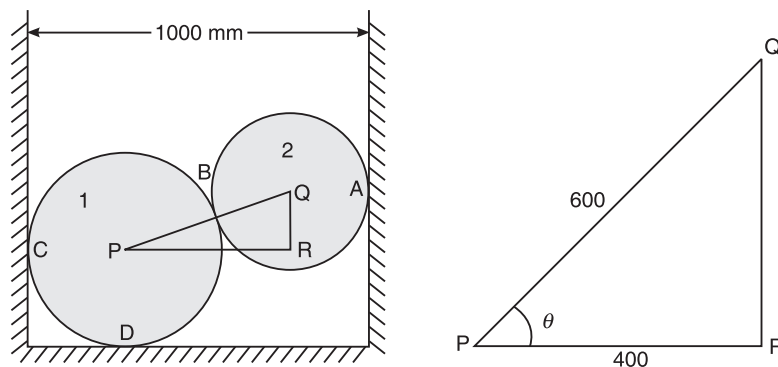

Figure 5.29 Example 5.14.

Solution

$$PR = 1000 - 350 - 250 = 400 \text{ mm}$$

$$PQ = 350 + 250 = 600 \text{ mm}$$

$$\cos \theta = \frac{PR}{PQ} = \frac{400}{600} = 48.18^\circ$$

If we consider the FBD of sphere 1 the number of unknowns is three and the equations available are two. Therefore it is necessary to consider the FBD of sphere 2 first.

Consider the FBD of sphere 2.

88 ELEMENTS OF CIVIL ENGINEERING AND ENGINEERING MECHANICS

Using Lami's theorem (Figure 5.30), we have

$$\frac{R_A}{\sin 138.18^\circ} = \frac{R_B}{\sin 90^\circ} = \frac{500}{\sin 131.82^\circ}$$

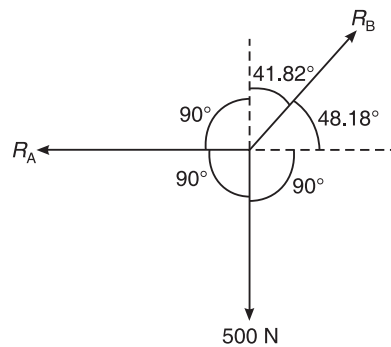

Figure 5.30 Example 5.14: FBD of sphere 2.

$$\therefore R_A = \frac{500}{\sin 131.82^\circ} \times \sin 138.82^\circ = 447.365 \text{ N} \quad \text{Ans.}$$

$$\text{and } R_B = \frac{500}{\sin 131.82^\circ} \times 1 = 670.922 \text{ N} \quad \text{Ans.}$$

Now, consider the FBD of sphere 1 (Figure 5.31).

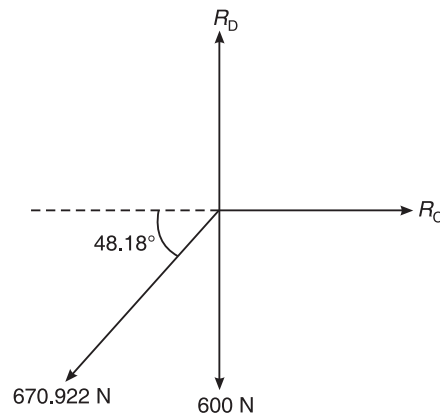

Figure 5.31 Example 5.14: FBD of sphere 1.

Applying the laws of equilibrium,

$$\begin{aligned} \text{For } \Sigma F_x &= 0 \\ \Rightarrow R_C - 670.922 \times \cos 48.18^\circ &= 0 \\ \therefore R_C &= 670.922 \times \cos 48.18^\circ = 447.366 \text{ N} \quad \text{Ans.} \end{aligned}$$

$$\begin{aligned} \text{For } \Sigma F_y &= 0 \\ \Rightarrow R_D - 600 - 670.922 \sin 48.18^\circ &= 0. \\ \therefore R_D &= 1100 \text{ N} \quad \text{Ans.} \end{aligned}$$

Example 5.15 Two identical rollers, each weighing 400 N, are placed in a trench as shown in Figure 5.32. Assuming that all contact surfaces are smooth, determine the reactions at contact points A, B, C, and D.

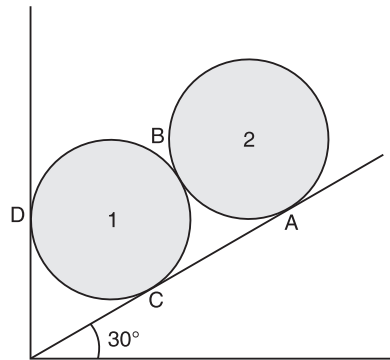

Figure 5.32 Example 5.15.

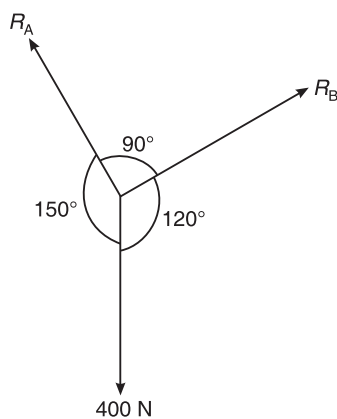

Figure 5.33 Example 5.15: FBD of sphere 2.

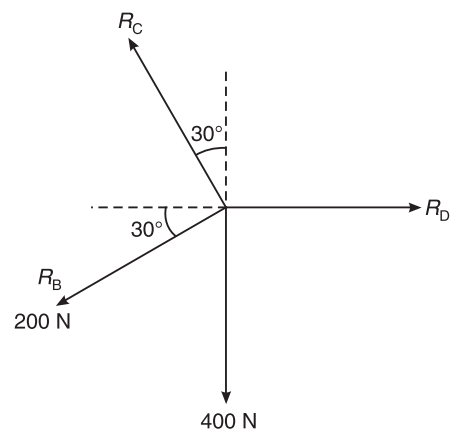

Figure 5.34 Example 5.15: FBD of sphere 1.

Solution Consider the FBD of sphere 2:

Applying Lami's theorem (Figure 5.33),

$$\frac{400}{\sin 90^\circ} = \frac{R_A}{\sin 120^\circ} = \frac{R_B}{\sin 150^\circ}$$

$$\therefore R_B = \frac{400 \times \sin 150^\circ}{\sin 90^\circ} = 200 \text{ N} \quad \text{Ans.}$$

$$\text{and } R_A = \frac{400 \times \sin 120^\circ}{\sin 90^\circ} = 346.410 \text{ N} \quad \text{Ans.}$$

From Figure 5.34,

$$\Sigma F_y = 0$$

$$\text{or } R_C \cos 30^\circ - 400 - 200 \sin 30^\circ = 0$$

90 ELEMENTS OF CIVIL ENGINEERING AND ENGINEERING MECHANICS

$$\therefore R_C = 577.850 \text{ N} \quad \text{Ans.}$$

$$\text{Also, } \Sigma F_x = 0$$

$$\text{or } -R_C \sin 30^\circ + R_D - R_B \cos 30^\circ = 0$$

$$\text{or } 577.850 \times \sin 30^\circ + 200 \cos 30^\circ = R_D$$

$$\therefore R_D = 461.880 \text{ N} \quad \text{Ans.}$$

Example 5.16 Determine the reactions at contact points P, Q, R, and S for the system shown in Figure 5.35. The radii of spheres 1 and 2 are, respectively, 20 mm and 30 mm.

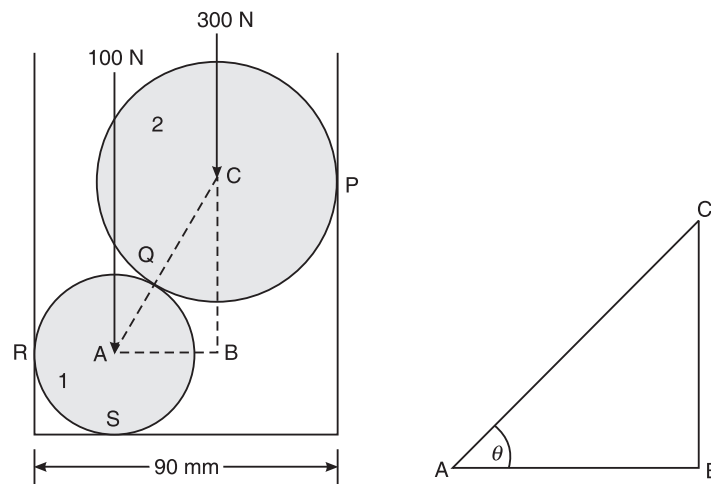

Figure 5.35 Example 5.16.

Solution Consider the FBD of sphere 2:

$$\cos \theta = \frac{AB}{AC} = \frac{90 - 20 - 30}{50} = \frac{40}{50}$$

$$\therefore \theta = 36.87^\circ$$

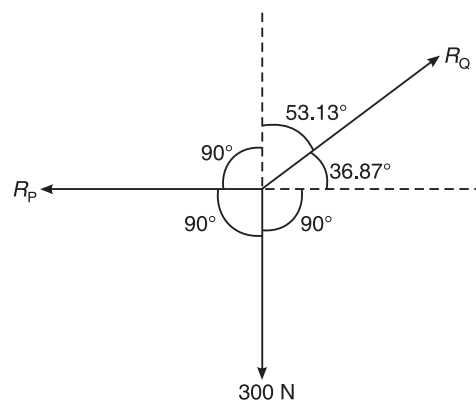

Figure 5.36 Example 5.16: Free body diagram of sphere 2.

Using Lami's theorem (Figure 5.36),

$$\frac{R_P}{\sin 126.87^\circ} = \frac{R_Q}{\sin 90^\circ} = \frac{300}{\sin 143.13^\circ}$$

$$\therefore R_P = \frac{300 \times \sin 126.87^\circ}{\sin 143.13^\circ} = 399.99 \text{ N} = 400 \text{ N} \quad \text{Ans.}$$

and $R_Q = \frac{300}{\sin 143.13^\circ} = 499.99 \text{ N} = 500 \text{ N} \quad \text{Ans.}$

Consider the FBD of sphere 1 (Figure 5.37),

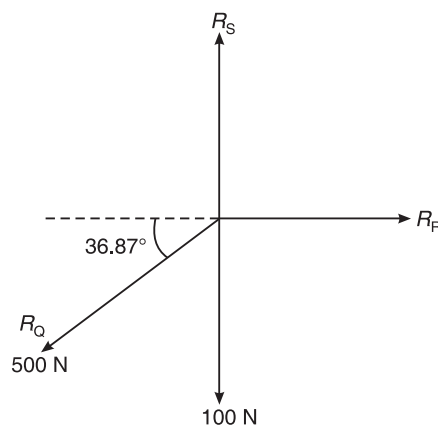

Figure 5.37 Example 5.16: Free body diagram of sphere 1.

$$\begin{aligned} \text{For } \Sigma F_x &= 0 \\ \Rightarrow R_R - 500 \cos 36.87^\circ &= 0 \end{aligned}$$

$$\therefore R_R = 500 \cos 36.87^\circ = 399.999 \text{ N} \quad \text{Ans.}$$

$$\begin{aligned} \text{For } \Sigma F_y &= 0 \\ \Rightarrow -500 \sin 36.87^\circ - 100 + R_S &= 0 \end{aligned}$$

$$\therefore R_S = 100 + 500 \sin 36.87^\circ = 400 \text{ N} \quad \text{Ans.}$$

Example 5.17 Calculate the reaction exerted at the contact points A, B, C, and D as shown in Figure 5.38.

Solution Consider the FBD of sphere 2 (Figure 5.39):

$$\frac{R_C}{\sin 140^\circ} = \frac{R_D}{\sin 130^\circ} = \frac{30 \times 9.81}{\sin 90^\circ}$$

Hence, $R_C = 189.172 \text{ N}, R_D = 225.446 \text{ N} \quad \text{Ans.}$

Consider the FBD of sphere 1 (Figure 5.40),

$$\begin{aligned} \text{For } \Sigma F_x &= 0 \\ \Rightarrow R_A \cos 50^\circ - R_B \cos 40^\circ - R_D \cos 50^\circ &= 0 \\ \text{or } R_A \cos 50^\circ - R_B \cos 40^\circ &= 144.913 \quad \text{(i)} \end{aligned}$$

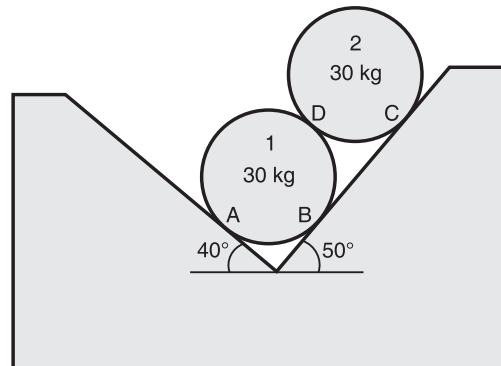
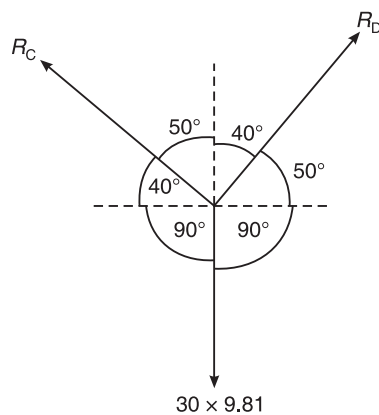
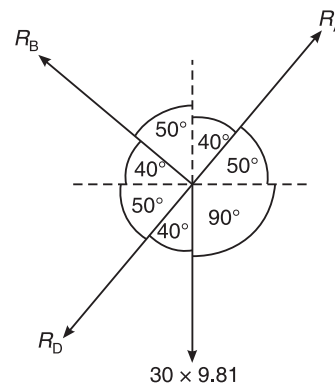

Figure 5.38 Example 5.17.

Figure 5.39 Example 5.17:
Free body diagram of sphere 2.Figure 5.40 Example 5.17:
Free body diagram of sphere 1.

For

$$\Sigma F_y = 0$$

$$R_A \sin 50^\circ + R_B \sin 40^\circ - R_D \cos 40^\circ - 30 \times 9.81 = 0$$

or

$$R_A \sin 50^\circ + R_B \sin 40^\circ = 30 \times 9.81 + R_D \cos 40^\circ = 467.001 \quad (\text{ii})$$

Now, (i) $\sin 40^\circ$ + (ii) $\cos 40^\circ$ gives

$$\begin{aligned} R_A \cos 50^\circ \times \sin 40^\circ - R_B \cos 40^\circ \times \sin 40^\circ + R_A \sin 50^\circ \times \cos 40^\circ + R_B \cos 40^\circ \times \sin 40^\circ \\ = (144.913) \sin 40^\circ + (467.001) \cos 40^\circ \end{aligned}$$

or

$$\begin{aligned} R_A \sin (50^\circ + 40^\circ) &= R_A \sin 90^\circ = R_A \\ \therefore &= 93.148 + 357.743 \end{aligned}$$

or

$$R_A = 450.891 \text{ N}$$

Ans.

Again,

$$R_A \cos 50^\circ - R_B \cos 40^\circ = 144.913$$

or

$$R_B = \frac{450.891 \times \cos 50^\circ - 144.913}{\cos 40^\circ}$$

 \therefore

$$R_B = 189.171 \text{ N}$$

Ans.

Example 5.18 Two spheres each of radius 100 mm and weight 5 kN are in a rectangular box as shown in Figure 5.41. Calculate the reactions at all the points of contact. VTU (January 2007)

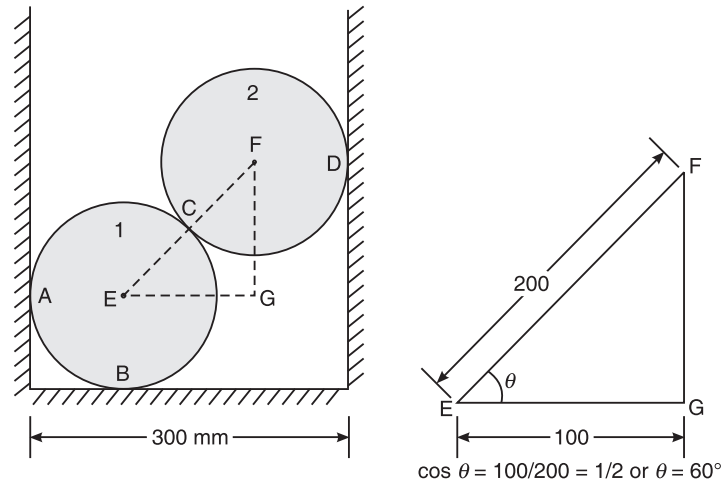

Figure 5.41 Example 5.18.

Solution Consider the FBD of sphere 2 (Figure 5.42),

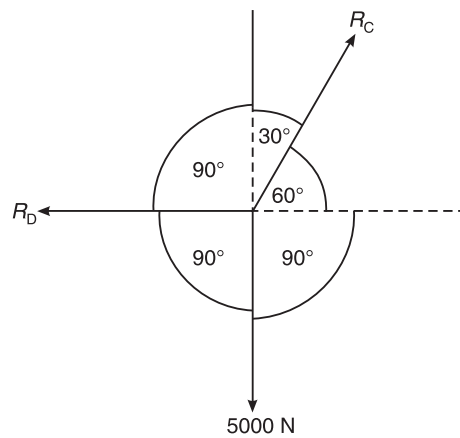

Figure 5.42 Example 5.18: Free body diagram of sphere 2.

Using Lami's theorem, we have

$$\frac{R_D}{\sin 150^\circ} = \frac{R_C}{\sin 90^\circ} = \frac{5000}{\sin 120^\circ}$$

or

$$\frac{R_D}{\sin 150^\circ} = \frac{5000}{\sin 120^\circ}$$

\therefore

$$R_D = 2886.751 \text{ N}$$

Ans.

94 ELEMENTS OF CIVIL ENGINEERING AND ENGINEERING MECHANICS

Now,
$$\frac{R_C}{\sin 90^\circ} = \frac{5000}{\sin 120^\circ}$$

$\therefore R_C = 5773.503 \text{ N}$

Ans.

Now consider the FBD of sphere 1 (Figure 5.43),

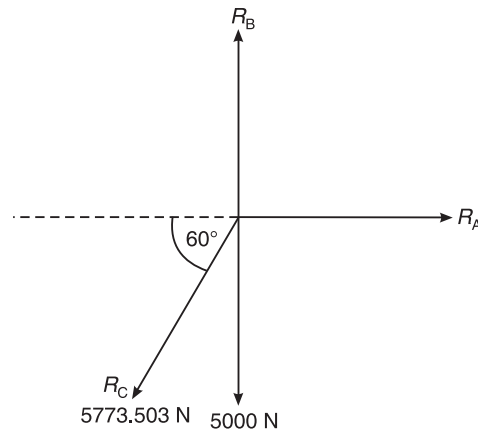

Figure 5.43 Example 5.18: Free body diagram of sphere 1.

Using equilibrium conditions, we have

$$\Sigma F_x = 0$$

or $R_A - 5773.503 \cos 60^\circ = 0$

$\therefore R_A = 2886.751 \text{ N}$

Ans.

Now, $\Sigma F_y = 0$

or $R_B - 5000 - 5773.503 \sin 60^\circ = 0$

$\therefore R_B = 10000 \text{ N}$

Ans.

Example 5.19 Write the free body diagram of identical spheres A and B shown in Figure 5.44.

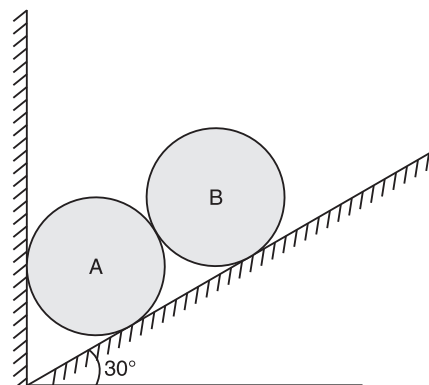

Figure 5.44 Example 5.19.

Solution

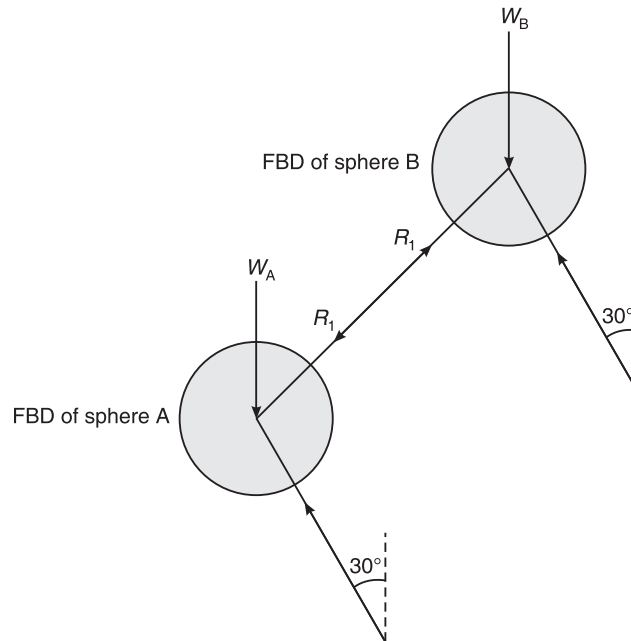

Figure 5.45 Example 5.19: Free body diagrams of spheres A and B.

Example 5.20 Determine the reactions at contact points for spheres A, B, and C as shown in Figure 5.46. It is given that:

$$W_A = W_B = 4 \text{ kN}, W_C = 6 \text{ kN}, d_A = d_B = 500 \text{ mm}, d_C = 800 \text{ mm}$$

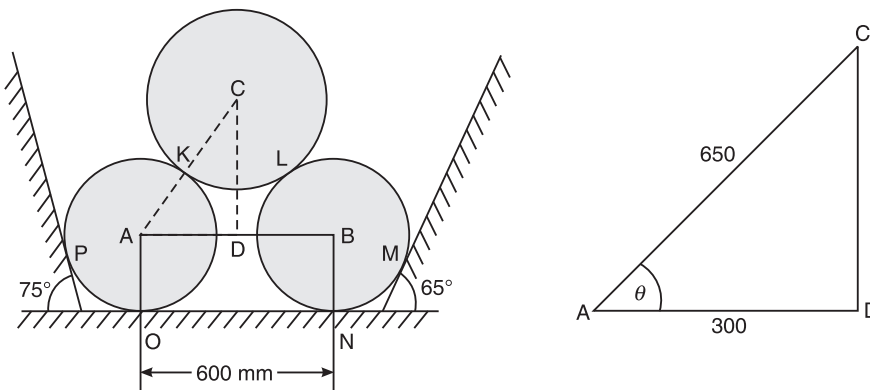

Figure 5.46 Example 5.20.

Solution

\therefore

$$\cos \theta = \frac{AD}{AC} = \frac{300}{650}$$
$$\theta = 62.51^\circ$$

96 ELEMENTS OF CIVIL ENGINEERING AND ENGINEERING MECHANICS

Consider the FBD of sphere C (Figure 5.47),

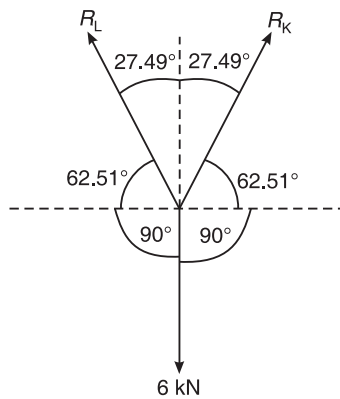

Figure 5.47 Example 5.20: Free body diagram of sphere C.

Using the Lami's theorem, we have

$$\frac{6}{\sin 54.98^\circ} = \frac{R_K}{\sin 152.51^\circ} = \frac{R_L}{\sin 152.51^\circ}$$

$$R_K = R_L = \frac{6}{\sin 54.98^\circ} \times \sin 152.51^\circ = 3.382 \text{ kN}$$

Ans.

Consider the FBD of sphere B (Figure 5.48),

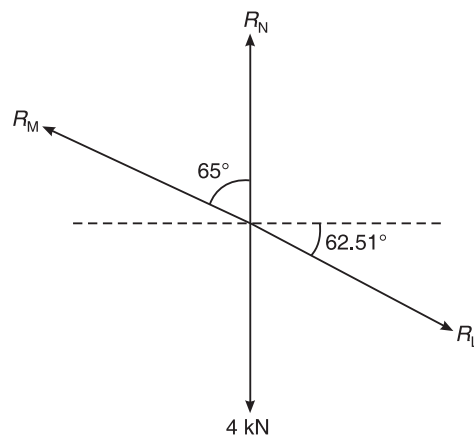

Figure 5.48 Example 5.20: Free body diagram of sphere B.

$$\Sigma F_x = 0$$

or

$$R_L \cos 62.51^\circ - R_M \sin 65^\circ = 0$$

\Rightarrow

$$R_M = \frac{R_L \cos 62.51^\circ}{\sin 65^\circ} = 1.722 \text{ kN}$$

Ans.

Also,

$$\Sigma F_y = 0$$

$$\begin{aligned} \text{or} \quad R_N - 4 - R_L \sin 62.51^\circ + R_M \cos 65^\circ &= 0 \\ \therefore R_N &= 4 + R_L \sin 62.51^\circ - R_M \cos 65^\circ = 6.272 \text{ kN} \end{aligned}$$

Ans.

Consider the FBD of sphere A (Figure 5.49),

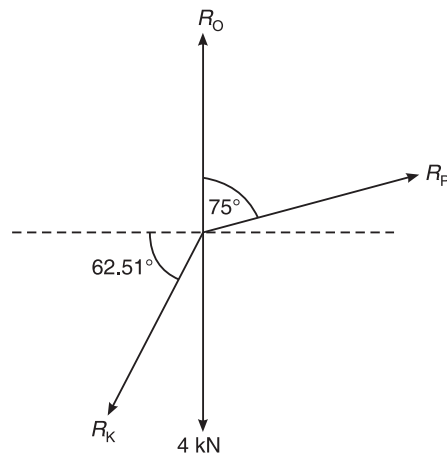

Figure 5.49 Example 5.20: Free body diagram of sphere A.

$$\begin{aligned} \Sigma F_x &= 0 \\ \text{or} \quad R_P \sin 75^\circ - R_K \cos 62.51^\circ &= 0 \\ \therefore R_P &= \frac{3.382 \times \cos 62.51^\circ}{\sin 75^\circ} = 1.616 \text{ N} \end{aligned}$$

Ans.

$$\begin{aligned} \text{Also,} \quad \Sigma F_y &= 0 \\ \text{or} \quad R_O - 4 + R_P \cos 75^\circ - R_K \sin 62.51^\circ &= 0 \\ \therefore R_O &= 4 + 3.382 \sin 62.51^\circ - 1.616 \cos 75^\circ = 6.582 \text{ kN} \end{aligned}$$

Ans.

Example 5.21 Determine the reactions at the surfaces of contact and the tension in the string AB shown in Figure 5.50. The radii of spheres, $R_1 = R_2 = R_3 = 200$ mm.

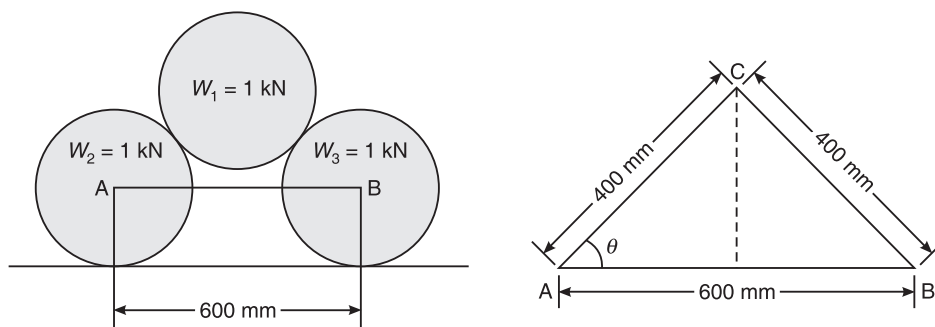

Figure 5.50 Example 5.21.

98 ELEMENTS OF CIVIL ENGINEERING AND ENGINEERING MECHANICS

Solution Two equal and opposite reactions will be developed between the contact surfaces of two bodies, as shown in Figure 5.51.

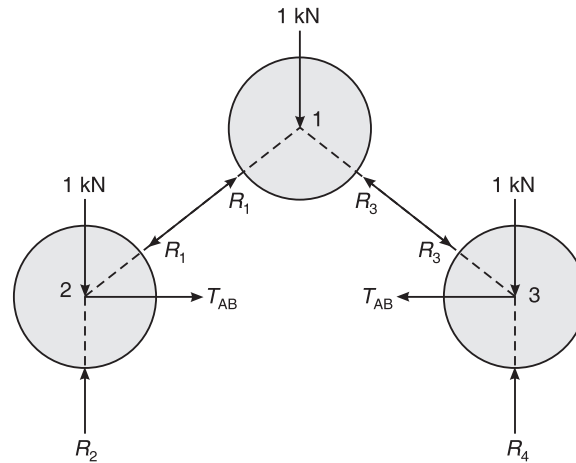

Figure 5.51 Example 5.21: Free body diagram.

Consider the FBD of sphere 1 (Figure 5.52),

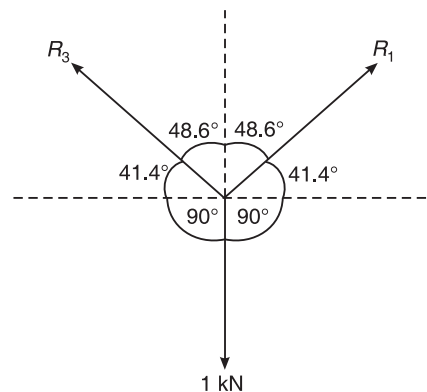

Figure 5.52 Example 5.21: Free body diagram of sphere 1.

Using Lami's theorem, we have

$$\frac{R_1}{\sin 131.40^\circ} = \frac{R_3}{\sin 131.40^\circ} = \frac{1}{\sin 97.20^\circ}$$

or

$$\frac{R_1}{\sin 131.40^\circ} = \frac{1}{\sin 97.20^\circ}$$

\therefore

$$R_1 = 0.756 \text{ kN}$$

Ans.

Also,

$$\frac{R_3}{\sin 131.40^\circ} = \frac{1}{\sin 97.20^\circ}$$

$\therefore R_3 = 0.756 \text{ kN}$ **Ans.**

Consider the FBD of sphere 2 (Figure 5.53),

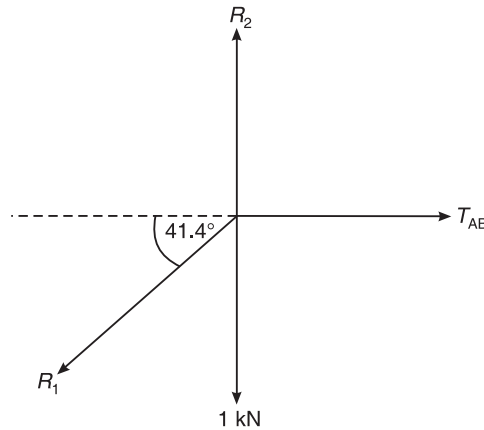

Figure 5.53 Example 5.21: Free body diagram of sphere 2.

Using the conditions of equilibrium, we have

$$\Sigma F_x = 0$$

or $T_{AB} - 0.756 \cos 41.40^\circ = 0$

$\therefore T_{AB} = 0.567 \text{ kN}$ **Ans.**

Also, $\Sigma F_y = 0$

or $R_2 - 0.756 \sin 41.40^\circ - 1 = 0$

$\therefore R_2 = 1.5 \text{ kN}$ **Ans.**

Consider the FBD of sphere 3 (Figure 5.54),

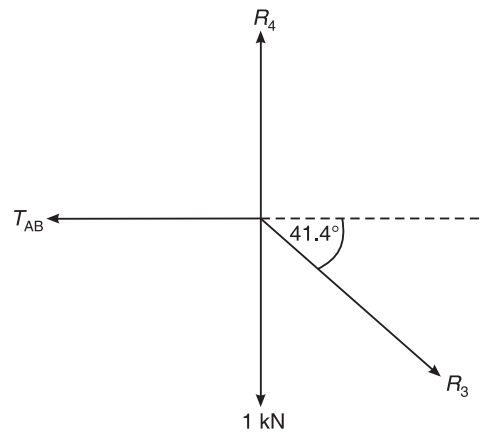

Figure 5.54 Example 5.21: Free body diagram of sphere 3.

100 ELEMENTS OF CIVIL ENGINEERING AND ENGINEERING MECHANICS

Using the conditions of equilibrium, we have

$$\Sigma F_y = 0$$

or $R_4 - 0.756 \sin 41.40^\circ - 1 = 0$

$\therefore R_4 = 1.5 \text{ kN}$

Ans.

Example 5.22 Two cylinders weighing 5000 N and 2500 N rest on a smooth inclined plane as shown in Figure 5.55. Neglecting the weight of the connecting bar, find the force P applied such that the system is in equilibrium.

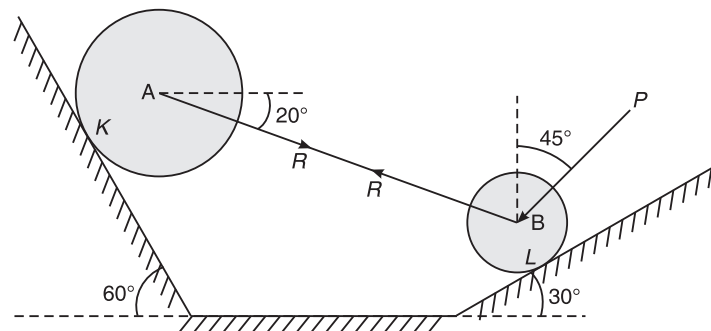

Figure 5.55 Example 5.22.

Solution Consider the FBD of sphere A (Figure 5.56).

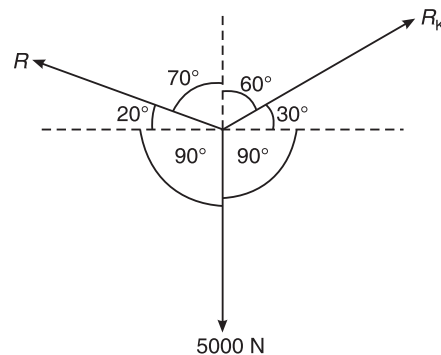

Figure 5.56 Example 2.22: Free body diagram of sphere A.

Using Lami's theorem, we have

$$R = \frac{5000}{\sin 130^\circ} \times \sin 120^\circ = 5652.579 \text{ N}$$

$$R_K = \frac{5000}{\sin 130^\circ} \times \sin 110^\circ = 6133.407 \text{ N}$$

Consider the FBD of sphere B (Figure 5.57),

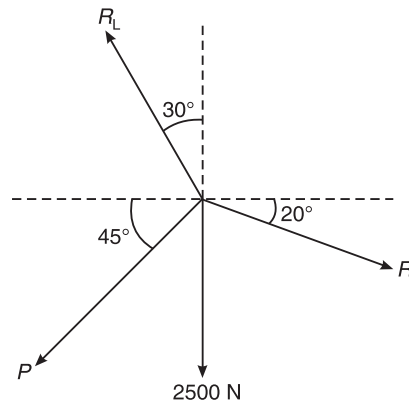

Figure 5.57 Example 5.22: Free body diagram of sphere B.

$$\Sigma F_x = 0$$

or $R \cos 20^\circ - R_L \sin 30^\circ - P \sin 45^\circ = 0$

or $R_L \sin 30^\circ + P \sin 45^\circ = 5311.686$ (i)

Also, $\Sigma F_y = 0$

or $R_L \cos 30^\circ - P \cos 45^\circ = 4433.295$ (ii)

Equations (i) and (ii) give

$$R_L \cos 30^\circ + R_L \sin 30^\circ = 9744.981$$

or $R_L \cos 30^\circ + 0.5R_L = 9744.981$

or $1.366R_L = 9744.981$

or $R_L = 7133.953 \text{ N}$

Substituting the value of R_L in Equation (ii), we get

$$7133.953 \times \cos 30^\circ - P \cos 45^\circ = 4433.295$$

or $P \cos 45^\circ = 1744.889$

$\therefore P = 2467.645 \text{ N}$

Ans.

EXERCISE PROBLEMS

1. A ball of weight 120 N rests in a right-angled groove as shown in Figure 5.58. The sides of the groove are inclined at an angle of 30° and 60° to the horizontal. If the entire surface is smooth, determine the reactions R_A and R_C at the points of contact.

$$[\text{Ans.: } R_A = 60 \text{ N, } R_C = 103.942 \text{ N}]$$

2. A circular roller of radius 5 cm and weight 100 N rests on a smooth horizontal surface and is held in position by an inclined bar AB of length 10 cm as shown in Figure 5.59. A horizontal force of 200 N is acting at B. Find the tension (force) in the bar AB and reaction at C.

$$[\text{Ans.: } T_{AB} = 230.94 \text{ N, } R_C = 215.47 \text{ N}]$$

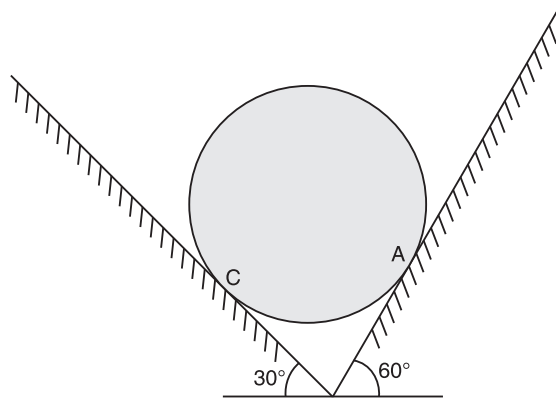

Figure 5.58

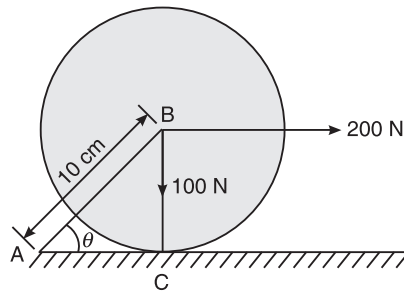

Figure 5.59

3. A pendulum ball weighs 50 N. It is pulled sideways by a horizontal force of 20 N. Calculate the angle of the rope of the pendulum to the vertical and tension in the string as shown in Figure 5.60. [Ans.: $\theta = 21.80^\circ$, $T = 53.85$ N]

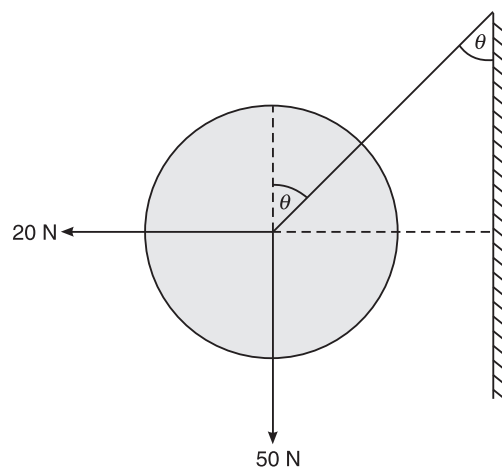

Figure 5.60

4. Two spheres each of weight 1000 N and of radius 25 cm rest in a horizontal channel of width 90 cm as shown in Figure 5.61. Find the reactions on the points of contact A, B, C and D. [Ans.: $R_A = 1333.333$ N, $R_B = 2000$ N, $R_C = 1333.333$ N, $R_D = 1666.667$ N]

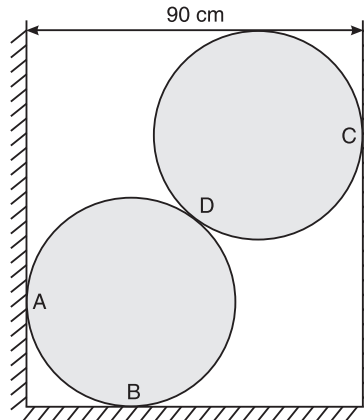

Figure 5.61

5. Two identical rollers each of weight 700 N are supported by an inclined plane and vertical wall as shown in Figure 5.62. Find the reaction exerted by the wall and the inclined plane at C, D, and F. [Ans.: $R_C = 808.288$ N, $R_D = 1010.36$ N, $R_E = 606.217$ N, $R_F = 350$ N]

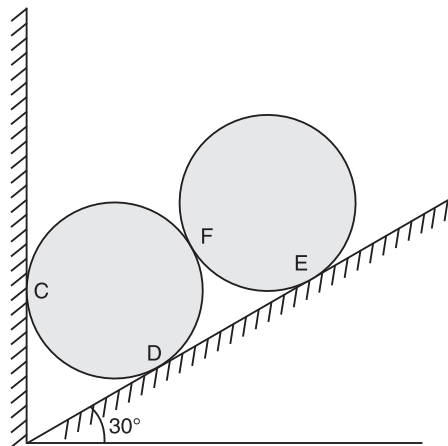

Figure 5.62

6. Two spheres are resting in a trench as shown in Figure 5.63. The weights and radii of the spheres are $W_1 = 75$ N, $W_2 = 10$ N, $r_1 = 425$ mm and $r_2 = 125$ mm, respectively. Determine the reactions acting on the spheres at A, B, C, and D, assuming the surface to be smooth. [Ans.: $R_A = 60.103$ N, $R_B = 48.43$ N, $R_C = 11.672$ N, $R_D = 8.436$ N]

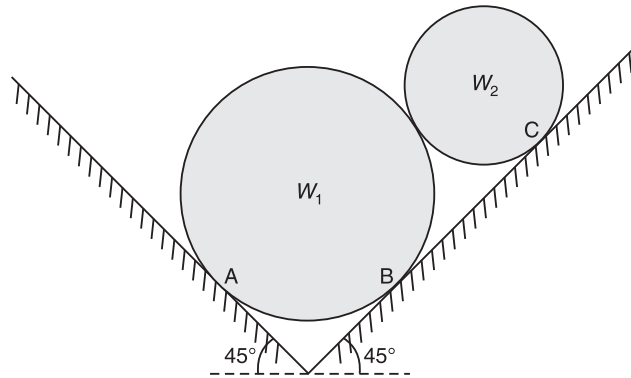

Figure 5.63

7. Two smooth spheres rest between two vertical columns as shown in Figure 5.64. The larger and smaller spheres weigh respectively 1200 N and 360 N. The diameters of the larger and smaller spheres are 36 cm and 16 cm respectively. Find the reactions at 1, 2, 3 and 4.

[Ans.: $R_1 = 1598$ N, $R_2 = 1566$ N, $R_3 = 1600$ N, $R_4 = 2000$ N]

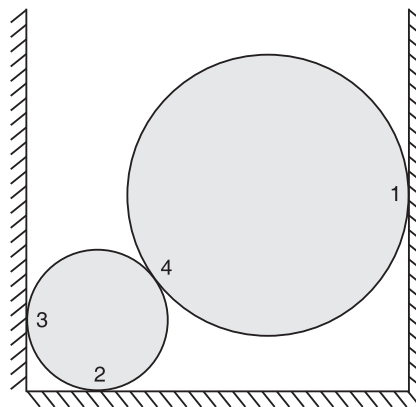

Figure 5.64

8. Two cylinders are placed as shown in Figure 5.65. Neglecting friction, find the reactions at all contact surfaces.

Given: Diameter of the first cylinder = 250 mm
 Diameter of the second cylinder = 150 mm
 Weight of the first cylinder = 400 N
 Weight of the second cylinder = 400 N

[Ans.: $R_A = 692.814$ N, $R_B = 923.748$ N, $R_C = 230.94$ N, $R_D = 461.88$ N]

9. Two smooth cylinders, each of weight $W = 1000$ N and radius 15 cm connected at their centres by a string AB of length = 40 cm, rest upon a horizontal plane and support above them a third cylinder of weight = 2000 N and radius 15 cm as shown in the Figure 5.66. Find the force S in the string AB and the pressure produced on the floor at the point of contacts D and E.

[Ans.: $R_D = 2000$ N, $R_E = 2000$ N, $R_F = 1342.28$ N, $R_G = 1342.28$ N, $S = 895.2$ N]

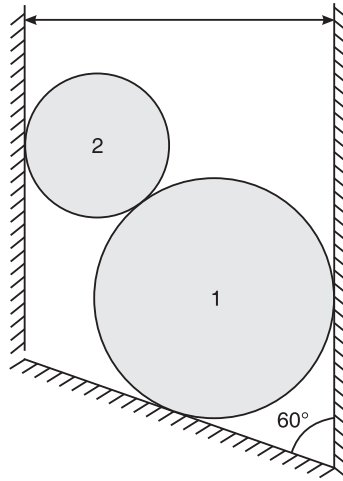

Figure 5.65

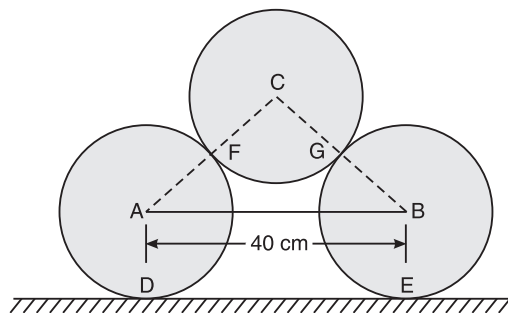

Figure 5.66

10. Four forces of magnitudes P , 100 N, 200 N, and 400 N are acting at a point as shown in Figure 5.67. Determine the magnitude and direction of force P such that the force system is in equilibrium. [Ans.: 434.14 N, $\theta = -22.77^\circ$]

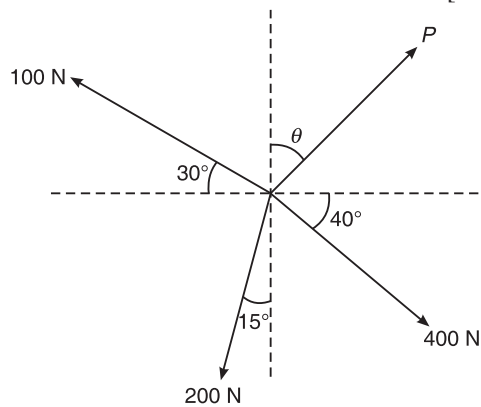

Figure 5.67

106 ELEMENTS OF CIVIL ENGINEERING AND ENGINEERING MECHANICS

11. A beam 20 m long supports a load of 12 kN, the cable AC is horizontal and 10 m long. Find the stress in the cable for the beam shown in Figure 5.68.

[Ans.: $T_{AC} = 6.928 \text{ kN}$, $T_{BC} = 13.856 \text{ kN}$]

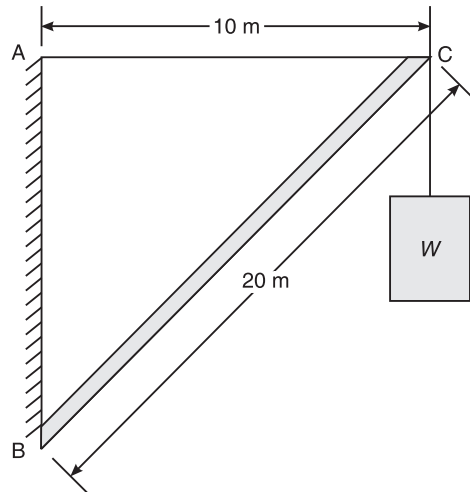

Figure 5.68

12. What axial forces does the vertical load 16 kN induce in the tie rod and in the jib of the crane shown in the Figure 5.69? Neglect the weight of the member.

[Ans.: $T_{BC} = 30.90 \text{ kN}$, $T_{AC} = 43.71 \text{ kN}$]

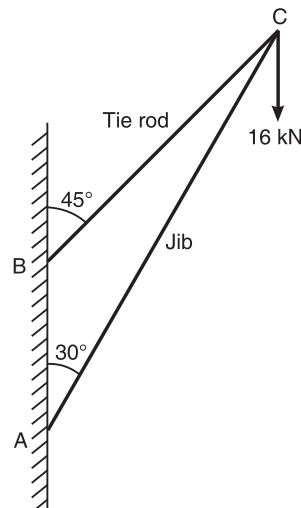

Figure 5.69

Hint: The tie rod will be under tension and the jib under compression.

13. A body weighing 16 kN is supported from a fixed point by a string 10 cm and is kept at rest by a horizontal force P at a distance of 6 cm from the vertical line drawn through the point of suspension. Find the tension in the string and the value of P (Figure 5.70).

[Ans.: $P = 12 \text{ kN}$]

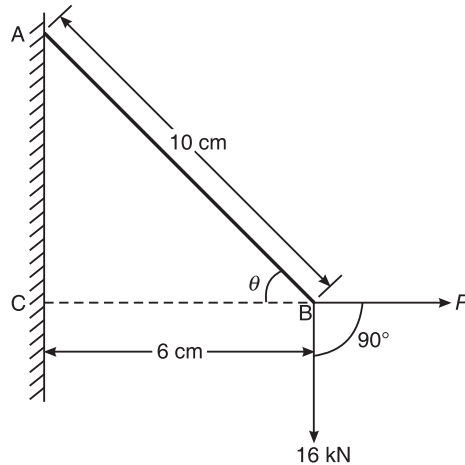

Figure 5.70

14. A body of weight 70 kN is supported by two strings whose lengths are 6 cm and 8 cm from two points in the same horizontal level. The horizontal distance between the two points is 10 cm. Determine the tensions in the string (Figure 5.71). [Ans.: $T_1 = 42$ kN, $T_2 = 56$ kN]

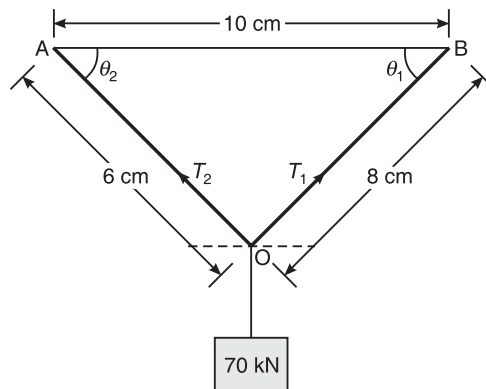

Figure 5.71

Hint:

$$AB^2 = AO^2 + OB^2$$

$$10^2 = 6^2 + 8^2$$

Therefore AOB is a right-angled triangle.

15. A chain ABCD attached to two fixed points A and D has two equal weights of 100 kN, attached to B and C as shown in Figure 5.72. Find the tension in the chains AB, BC and CD. [Ans.: $T_{AB} = 173.20$ kN, $T_{BC} = 100$ kN, $T_{CD} = 100$ kN]
16. A string ABCD is tied at A and D to hooks as shown in Figure 5.73. At C, weight of 433 N is a suspended. And at B, an unknown weight W is suspended such that BC is horizontal and AB and CD are inclined at 45° and 60° , respectively, to the horizontal. Determine the tensions in AB, BC and CD and find the magnitude W . [Ans.: $T_{AB} = 353$ N, $T_{BC} = 250$ N, $T_{CD} = 500$ N, $W = 250$ N]

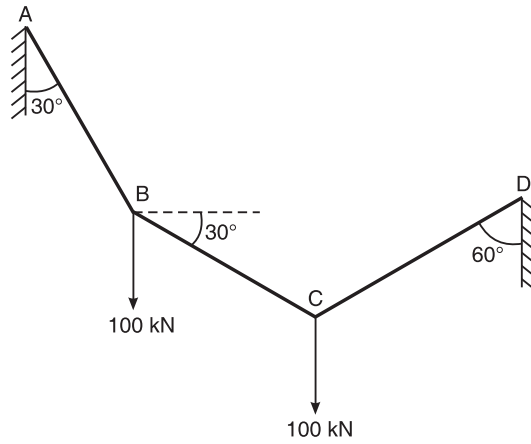

Figure 5.72

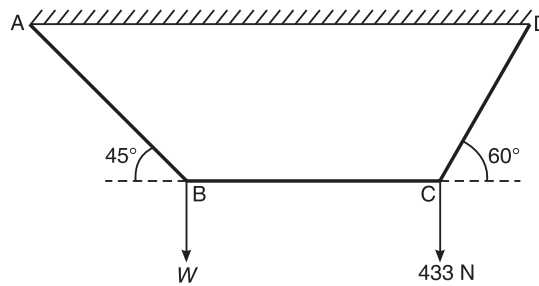

Figure 5.73

17. Figure 5.74 shows an arrangement to which the weights 440 N and 560 N are suspended. The pulley at E is frictionless. Find the tension in the string BC, reaction at E, and inclination of string DB at D for the equilibrium condition.

[Ans.: $R_E = 791.959 \text{ N}$, $T_{AB} = 1000 \text{ N}$, $T_{ED} = 560 \text{ N}$,
 $T_{BC} = 622.14 \text{ N}$, $\theta = 38.15^\circ$, $T_{BD} = 12.17 \text{ N}$]

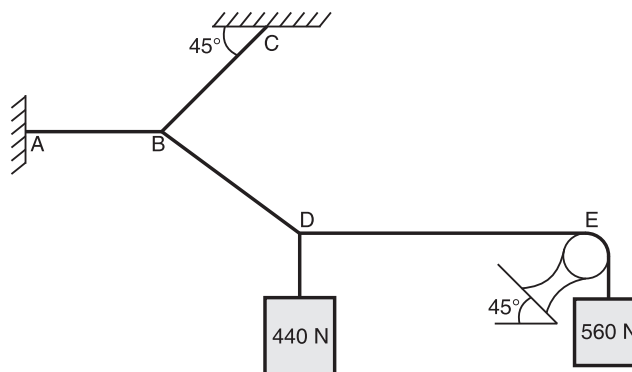

Figure 5.74

Hint: Reaction at E is perpendicular to the plane. Consider the FBD at E, D and B respectively.

EQUILIBRIUM OF COPLANAR NON-CONCURRENT FORCE SYSTEM

SUPPORT REACTIONS

The various structural members are connected to the surroundings by various types of supports. The structural members exert forces on supports known as *action*. Similarly, the supports exert forces on structural members known as *reaction*.

A beam is a horizontal member, which is generally placed on supports. The beam is subjected to vertical forces known as action. Supports exert forces, known as reaction, on the beam.

Types of Supports

The following types of supports are found in practice:

1. Simple supports
2. Roller supports
3. Hinged or pinned supports
4. Fixed supports

Simple supports

Simple supports (Figure 6.1) are those which exert reactions perpendicular to the plane of support. They restrict translation of the body in one direction only, but do not restrict rotation.

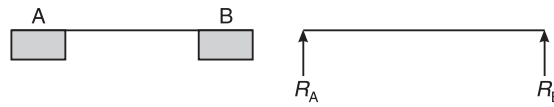

Figure 6.1 Simple supports.

Roller supports

Roller supports (Figure 6.2) are those which exert reactions perpendicular to the plane of the support. They restrict translation of the body along one direction only, and rotation is allowed.

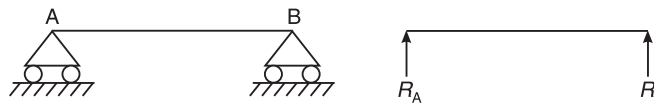

Figure 6.2 Roller supports.

Hinged or pinned supports

Hinged supports (Figure 6.3) are those which exert reactions in any direction, but from our convenient point of view we resolve these reactions into two components. Therefore, hinged supports restrict translation in both directions. But rotation is possible.

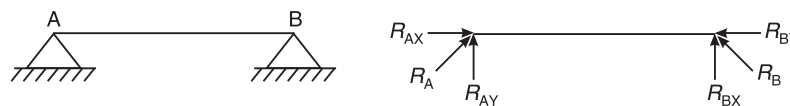

Figure 6.3 Hinged supports.

Fixed supports

Fixed supports (Figure 6.4) are those which restrict both translation and rotation of the body. Fixed supports develop an internal moment known as *restraint* moment to prevent the rotation of the body.

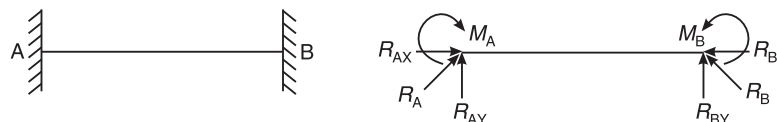

Figure 6.4 Fixed supports.

Types of Beams

Simply supported beam

It is a beam which consists of simple supports (Figure 6.5). Such a beam can resist forces normal to the axis of the beam.

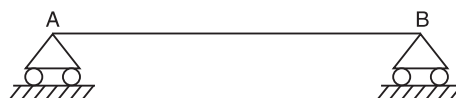

Figure 6.5 Simply supported beam.

Continuous beam

It is a beam which consists of three or more supports (Figure 6.6).

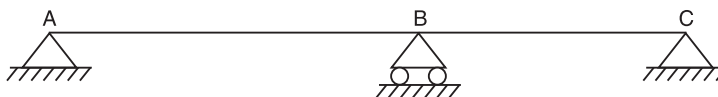

Figure 6.6 Continuous beam.

Cantilever beam

It is a beam whose one end is fixed and the other end is free (Figure 6.7).



Figure 6.7 Cantilever beam.

Propped cantilever beam

It is a beam whose one end is fixed and the other end is simply supported (Figure 6.8).

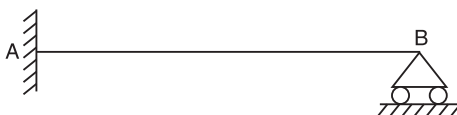

Figure 6.8 Propped cantilever beam.

Overhanging beam

It is a beam which extends beyond support(s). In Figure 6.9, it is seen that the beam extends beyond support B up to C. The overhang portion is BC.

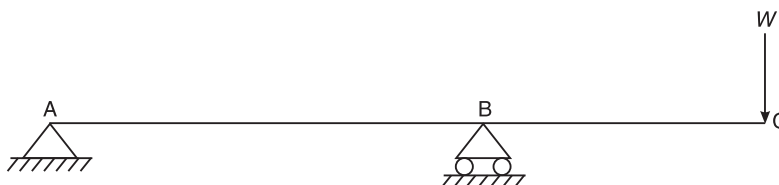

Figure 6.9 Overhanging beam.

Types of Loads

Concentrated load

A load which is concentrated at a point in a beam is known as concentrated load (Figure 6.10).

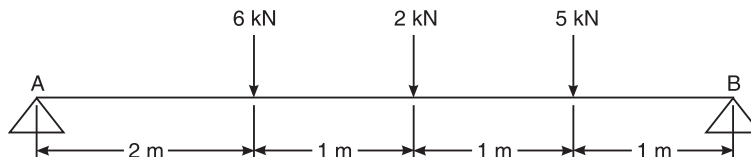

Figure 6.10 Concentrated loads.

Uniformly distributed load

A load which is distributed uniformly along the entire length of the beam is known as uniformly distributed load (such as the load 20 kN per metre (UDL), length shown in Figure 6.11).

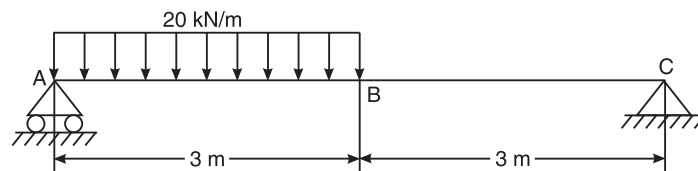

Figure 6.11 Uniformly distributed load.

To convert the 20 kN/m UDL into a point load which is acting at the centre of a particular span (i.e. 3 m), we proceed as follows:

$$\text{Magnitude of point load} = 20 \text{ kN/m} \times 3 \text{ m} = 60 \text{ kN}$$

Uniformly varying load

A load which varies with the length of the beam is known as uniformly varying load (Figure 6.12). The magnitude of the point load corresponding to a uniformly varying load such as that shown in Figure 6.12, is calculated as follows:

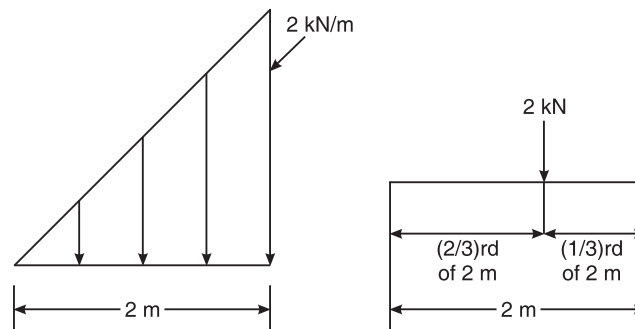

Figure 6.12 Uniformly varying load.

$$\text{Magnitude of point load} = \text{Area of the triangle} = \frac{1}{2} \times \text{base} \times \text{height} = \frac{1}{2} \times 2 \times 2 = 2 \text{ kN}$$

The point load acts at the centre of gravity (CG) of the triangle.

PROBLEMS ON EQUILIBRIUM OF COPLANAR NON-CONCURRENT FORCE SYSTEM

Tips to Solve the Problems

1. In a coplanar non-concurrent force system, three conditions of equilibrium can be applied, namely as follows:

$$\Sigma F_x = 0, \quad \Sigma F_y = 0 \quad \text{and} \quad \Sigma M = 0$$

2. Draw the free body diagram of the given beam by showing all the forces and reactions acting on the beam.
3. Apply the three conditions of equilibrium to calculate the unknown reactions at the supports.

Example 6.1 A simply supported beam of length (span) 5 m is loaded as shown in Figure 6.13. Find the reactions at A and B.

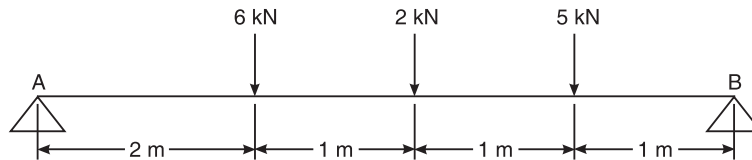

Figure 6.13 Example 6.1.

Solution It is a coplanar non-concurrent force system, therefore, it is possible to apply three conditions of equilibrium to calculate the reactions at the supports A and B.

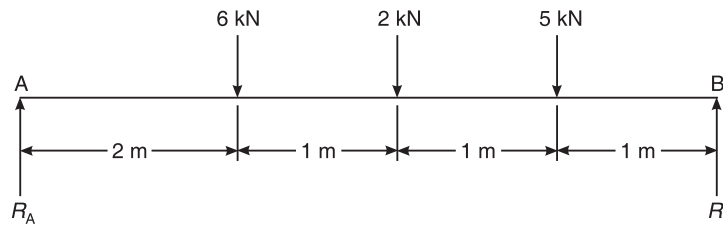

Figure 6.14 Example 6.1.

$$\begin{aligned} \Sigma F_y &= 0 \\ \text{or } R_A + R_B - 6 - 2 - 5 &= 0 \\ \text{or } R_A + R_B &= 13 \\ \Sigma M_A &= 0 \\ \text{or } -R_B \times 5 + 6 \times 2 + 2 \times 3 + 5 \times 4 &= 0 \\ \text{or } 5R_B = 38 &\Rightarrow R_B = 7.6 \text{ kN} && \text{Ans.} \\ \therefore R_A = 13 - 7.6 &= 5.4 \text{ kN} && \text{Ans.} \end{aligned}$$

Example 6.2 A simply supported beam of span 6 m is subjected to loading as shown in Figure 6.15. Determine the reactions at A and B.

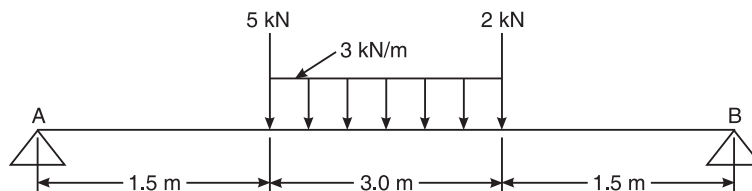

Figure 6.15 Example 6.2.

114 ELEMENTS OF CIVIL ENGINEERING AND ENGINEERING MECHANICS

Solution Converting the UDL of 3 kN/m over a span of 3 m into a point load, and applying the laws of equilibrium (Figure 6.16), we get

$$F_y = 0$$

$$\text{or } R_A + R_B - 5 - 9 - 2 = 0$$

$$\text{or } R_A + R_B = 16$$

$$\Sigma M_B = 0$$

$$\text{or } -2 \times 1.5 - 9 \times 3 - 5 \times 4.5 + R_A \times 6 = 0$$

$$\therefore R_A = \frac{52.5}{6} = 8.75 \text{ kN} \quad \text{Ans.}$$

$$\text{or } R_B = 7.25 \text{ kN} \quad \text{Ans.}$$

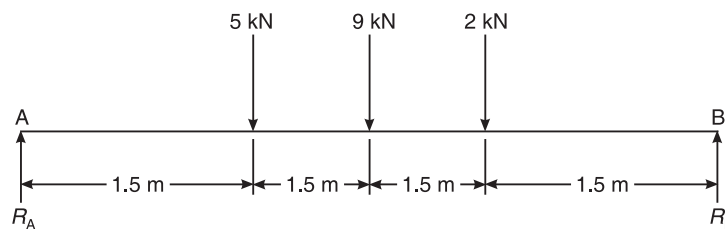

Figure 6.16 Example 6.2.

Example 6.3 Determine the reactions at A and E for the beam shown in Figure 6.17.

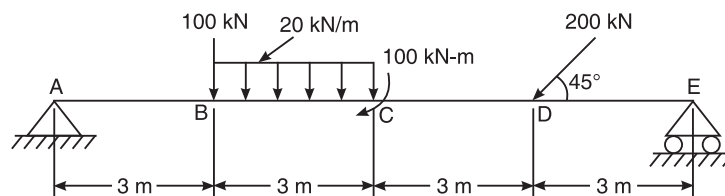

Figure 6.17 Example 6.3.

Solution Converting the UDL of 20 kN/m over a span of 3 m into a point load, and applying the laws of equilibrium (Figure 6.18), we get

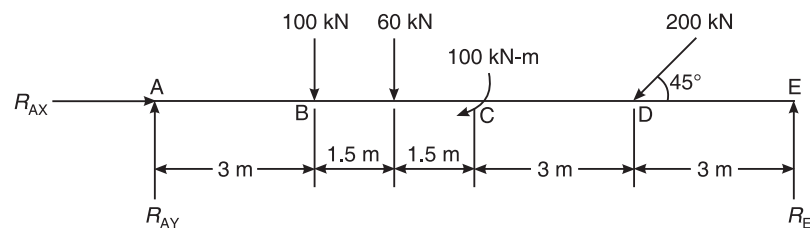

Figure 6.18 Example 6.3.

$$\Sigma F_x = 0$$

$$\text{or } R_{AX} - 200 \cos 45^\circ = 0$$

$$\therefore R_{AX} = 141.421 \text{ kN} \quad \text{Ans.}$$

$$\Sigma F_y = 0$$

$$\text{or } R_E + R_{AY} - 100 - 60 - 200 \sin 45^\circ$$

$$\text{or } R_E + R_{AY} = 301.421 \quad \text{(i)}$$

$$\Sigma M_A = 0$$

$$\text{or } -R_E \times 12 + 200 \sin 45^\circ \times 9 + 60 \times 4.5 + 100 \times 3 + 100 = 0$$

$$\therefore R_E = 161.899 \text{ kN} \quad \text{Ans.}$$

Substituting R_E in (i), we get

$$161.899 + R_{AY} = 301.421$$

$$\therefore R_{AY} = 139.522 \text{ kN} \quad \text{Ans.}$$

Example 6.4 Determine the distance x such that R_A and R_B are equal, for the beam shown in Figure 6.19. VTU (January 2007)

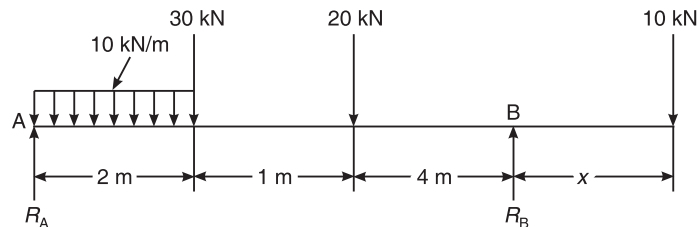

Figure 6.19 Example 6.4.

Solution Applying the conditions of equilibrium to calculate the value of x , we have

$$\Sigma F_y = 0$$

$$\text{or } R_A + R_B - 30 - 20 - 10 - 20 = 0$$

$$\text{or } 2R_A - 80 = 0$$

$$\therefore R_A = R_B = 40 \text{ kN} \quad (\text{since } R_A = R_B)$$

$$\Sigma M_A = 0$$

$$\text{or } 20 \times 1 + 30 \times 2 + 20 \times 3 - 40 \times 7 + 10(7 + x) = 0$$

$$\therefore x = 7 \text{ m} \quad \text{Ans.}$$

Example 6.5 For the beam with loading shown in Figure 6.20, determine the reactions at the supports. VTU (February 2004)

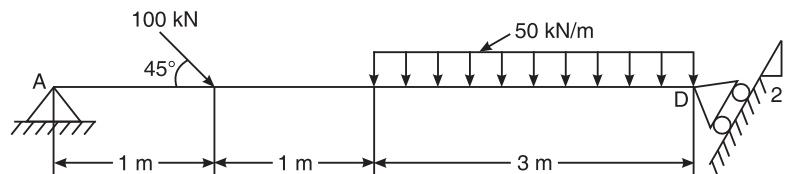

Figure 6.20 Example 6.5.

116 ELEMENTS OF CIVIL ENGINEERING AND ENGINEERING MECHANICS

Solution

$$\tan \theta = \frac{1}{2}$$

$$\Rightarrow \theta = \tan^{-1} \left(\frac{1}{2} \right) = 26.56^\circ$$

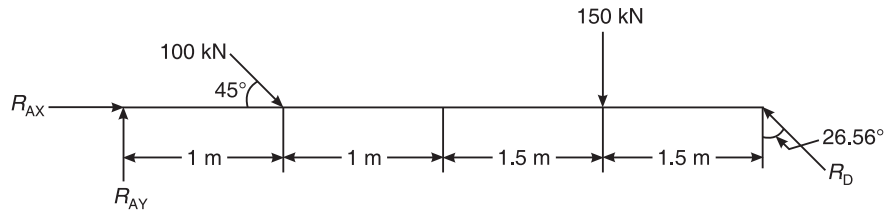
**Figure 6.21** Example 6.5.

$$\Sigma F_x = 0$$

$$\text{or } R_{AX} + 100 \cos 45^\circ - R_D \sin 26.56^\circ = 0$$

$$\text{or } R_{AX} - 0.477 R_D = 70.71 \quad \text{(i)}$$

$$\Sigma F_y = 0$$

$$R_{AY} + R_D \cos 26.56^\circ - 100 \sin 45^\circ - 150 = 0$$

$$R_{AY} + 0.894 R_D = 220.71 \quad \text{(ii)}$$

$$\Sigma M_A = 0$$

$$-5R_D \cos 26.56^\circ + 150 \times 3.5 + 100 \sin 45^\circ \times 1 = 0$$

$$\therefore R_D = 133.199 \text{ kN} \quad \text{Ans.}$$

Substituting the value of R_D in (i), we get

$$R_{AX} = -11.15 \text{ kN}$$

Substituting the value of R_D in (ii), we get

$$R_{AY} = 101.63 \text{ kN}$$

$$R_A = \sqrt{R_{AX}^2 + R_{AY}^2} = \sqrt{(-7.174)^2 + (101.63)^2} = 101.88 \text{ kN} \quad \text{Ans.}$$

Example 6.6 Find the support reactions at A and B for the beam loaded as shown in Figure 6.22. VTU (July 2006)

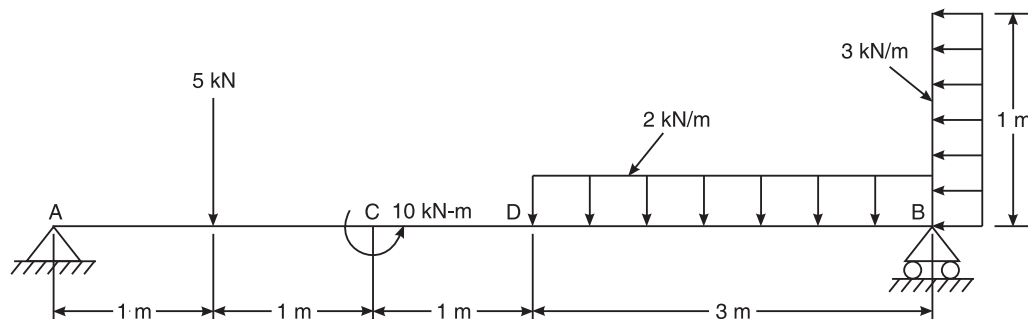
**Figure 6.22** Example 6.6.

Solution Using the conditions of equilibrium, we have

$$\begin{aligned} \Sigma F_x &= 0 \\ \text{or } R_{AX} - 3 &= 0 \\ \therefore R_{AX} &= 3 \text{ kN} \\ \Sigma F_y &= 0 \\ R_{AY} + R_B - 5 - 6 &= 0 \\ \therefore R_{AY} + R_B &= 11 \end{aligned} \quad (i)$$

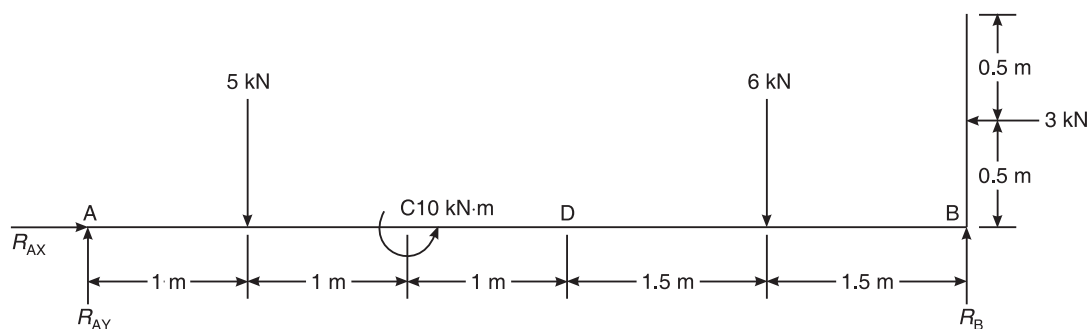

Figure 6.23 Example 6.6.

$$\begin{aligned} \text{Also, } \Sigma M_A &= 0 \\ \text{or } -R_B \times 6 + 5 \times 1 + 6 \times 4.5 - 3 \times 0.5 - 10 & \\ \therefore R_B &= 3.417 \text{ kN} \end{aligned} \quad \text{Ans.}$$

Substituting the value of R_B in (i), we get

$$\begin{aligned} R_{AY} + 3.417 &= 11 \\ \therefore R_{AY} &= 7.583 \text{ kN} \\ R_A &= \sqrt{R_{AX}^2 + R_{AY}^2} = \sqrt{(3)^2 + (7.583)^2} \\ \therefore R_A &= 8.155 \text{ kN} \end{aligned} \quad \text{Ans.}$$

Example 6.7 Calculate the support reactions for the cantilever beam shown in Figure 6.24.

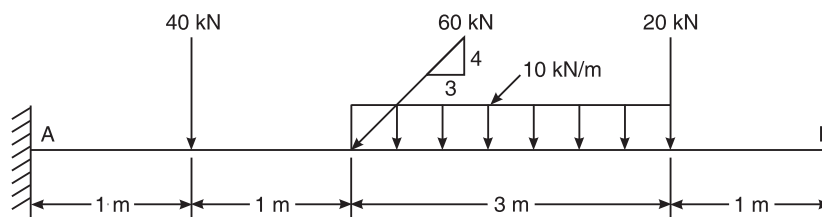

Figure 6.24 Example 6.7.

Solution Using Figure 6.25,

$$\begin{aligned} \Sigma F_x &= 0 \\ \text{or } R_{AX} - 60 \cos 53.13^\circ &= 0 \end{aligned}$$

118 ELEMENTS OF CIVIL ENGINEERING AND ENGINEERING MECHANICS

$$\therefore R_{AX} = 60 \cos 53.13^\circ = 36 \text{ kN} \quad \text{Ans.}$$

Also, $\Sigma F_y = 0$
 or $R_{AY} - 40 - 60 \sin 53.13^\circ - 30 - 20 = 0$

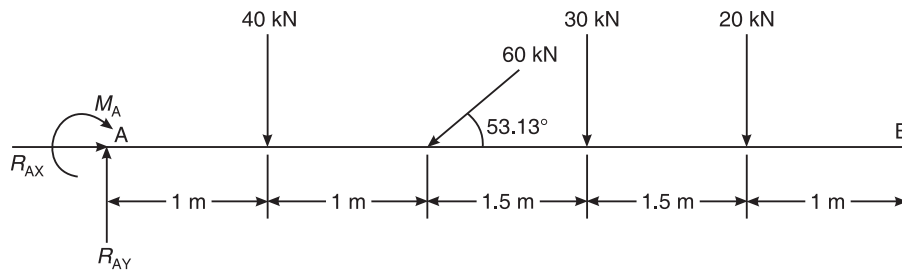

Figure 6.25 Example 6.7.

$$\therefore R_{AY} = 138 \text{ kN} \quad \text{Ans.}$$

$$\Sigma M_A = 0$$

or $40 \times 1 + 60 \sin 53.13^\circ \times 2 + 30 \times 3.5 + 20 \times 5 + M_A = 0$

$$\therefore M_A = -341 \text{ kN-m}$$

Our assumption is wrong.

\therefore The moment at A is anticlockwise in nature. Ans.

Example 6.8 Calculate the support reactions for the cantilever beam shown in Figure 6.26.

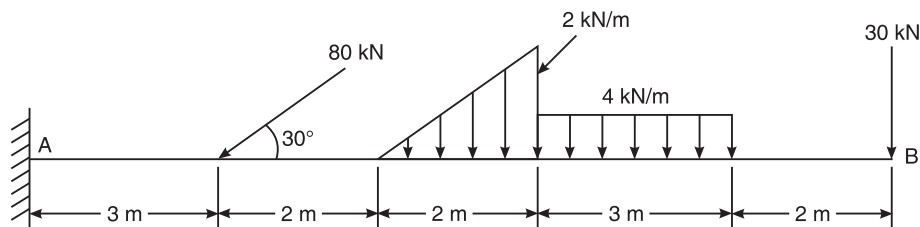

Figure 6.26 Example 6.8.

Solution First, we convert the rectangular load into point load,

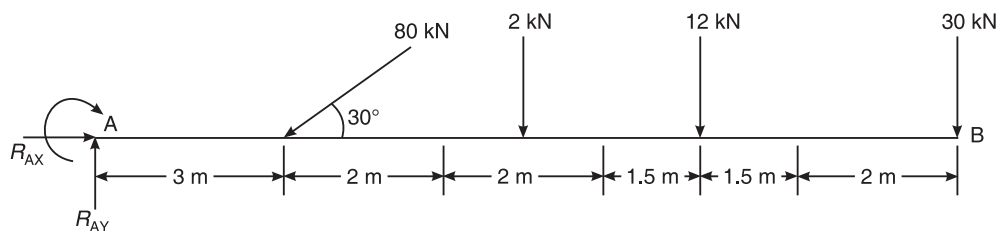

Figure 6.27 Example 6.8.

$$\text{Magnitude of load} = \text{Area of triangle} = (1/2) \times 2 \times 2 = 2 \text{ kN}$$

Load is acting at the CG of the triangle as shown in Figure 6.28.

$$\begin{aligned} \text{Now,} \quad & \Sigma F_x = 0 \\ \text{or} \quad & R_{AX} = 80 \cos 30^\circ = 0 \\ \therefore & R_{AX} = 69.282 \text{ kN} \end{aligned}$$

Ans.

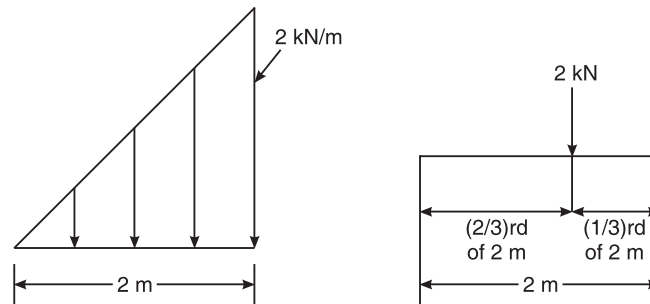

Figure 6.28 Example 6.8.

$$\begin{aligned} \text{or} \quad & \Sigma F_y = 0 \\ & R_{AY} - 80 \sin 30^\circ - 2 - 12 - 30 = 0 \\ \therefore & R_{AY} = 84 \text{ kN} \\ \text{Now,} \quad & \Sigma M_A = 0 \end{aligned}$$

Ans.

$$\begin{aligned} \text{or} \quad & +80 \sin 30^\circ \times 3 + 2 \left(\frac{2}{3} \times 2 + 5 \right) + 12 \times 8.5 + 30 \times 12 + M_A = 0 \\ \therefore & M_A = -594.667 \text{ kN-m} \end{aligned}$$

Ans.

M_A is in anticlockwise direction.

Example 6.9 Determine the reactions at the supports A and B for a beam loaded as shown in Figure 6.29.

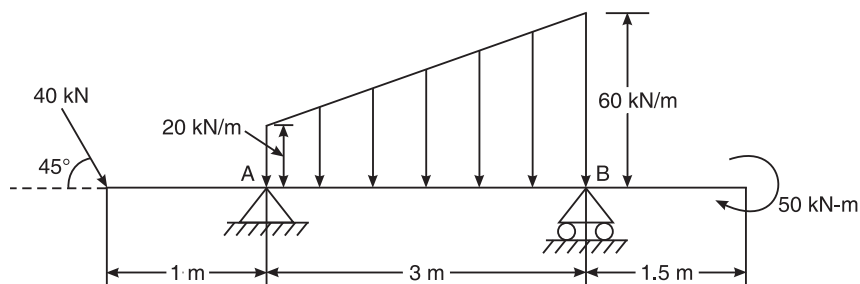

Figure 6.29 Example 6.9.

Solution Using the conditions of equilibrium shown in Figure 6.30, we have

$$\begin{aligned} & \Sigma F_x = 0 \\ \text{or} \quad & 40 \cos 45^\circ - R_{AX} = 0 \\ \therefore & R_{AX} = 28.284 \text{ kN} \\ & \Sigma F_y = 0 \end{aligned}$$

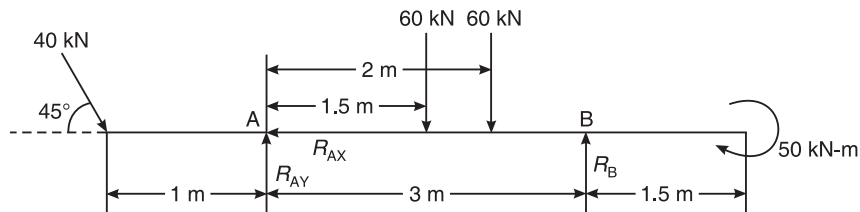

Figure 6.30 Example 6.9.

or $R_{AY} + R_B - 40 \sin 45^\circ - 60 - 60 = 0$

or $R_{AY} + R_B = 148.284$ (i)

Now, $\Sigma M_A = 0$

or $-R_B \times 3 + 60 \times 1.5 + 60 \times 2 + 50 - 40 \sin 45^\circ \times 1 = 0$

$\therefore R_B = 77.238 \text{ kN}$ **Ans.**

Substituting the value of R_B in (i), we get

$$R_{AY} = 71.046 \text{ kN}$$

$\therefore R_A = \sqrt{R_{AX}^2 + R_{AY}^2}$

$R_A = \sqrt{(28.284)^2 + (71.046)^2} = 78.469 \text{ kN}$ **Ans.**

$\theta = \tan^{-1} \left(\frac{71.046}{28.284} \right) = 68.29^\circ$ **Ans.**

Example 6.10 Find the support reactions of the beam loaded as shown in Figure 6.31.

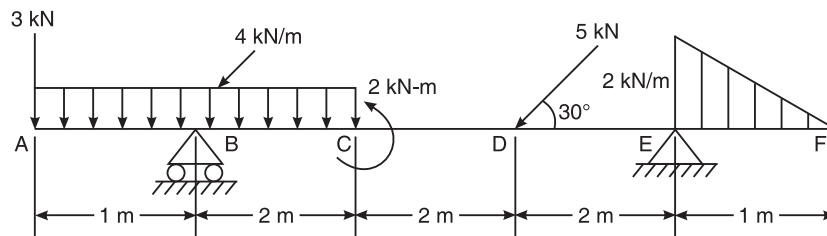

Figure 6.31 Example 6.10.

Solution Using the conditions of equilibrium shown in Figure 6.32, we have

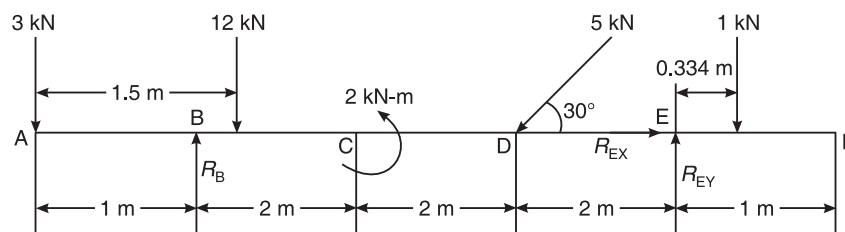

Figure 6.32 Example 6.10.

$$\begin{aligned} & \Sigma F_x = 0 \\ \text{or} & R_{EX} - 5 \cos 30^\circ = 0 \\ \therefore & R_{EX} = 4.33 \text{ kN} \\ \text{Also,} & \Sigma F_y = 0 \\ \text{or} & R_B + R_{EY} - 3 - 12 - 5 \sin 30^\circ - 1 = 0 \\ \text{or} & R_B + R_{EY} = 18.5 \quad (i) \\ \text{Also,} & \Sigma M_B = 0 \\ \text{or} & -R_{EY} \times 6 + 12 \times 0.5 - 3 \times 1 - 2 + 5 \sin 30^\circ \times 4 + 1 \times 6.334 = 0 \\ \therefore & R_{EY} = 2.889 \text{ kN} \end{aligned}$$

Substituting the value of R_{EY} in (i), we get

$$R_B = 15.611 \text{ kN} \quad \text{Ans.}$$

$$R_E = \sqrt{(4.33)^2 + (2.889)^2} = 5.205 \text{ kN} \quad \text{Ans.}$$

$$\theta = \tan^{-1} \left(\frac{R_{EY}}{R_{EX}} \right)$$

$$\therefore \theta = \tan^{-1} \left(\frac{2.889}{4.33} \right) = 33.71^\circ \quad \text{Ans.}$$

Example 6.11 Find the support reactions for the beam shown in Figure 6.33.

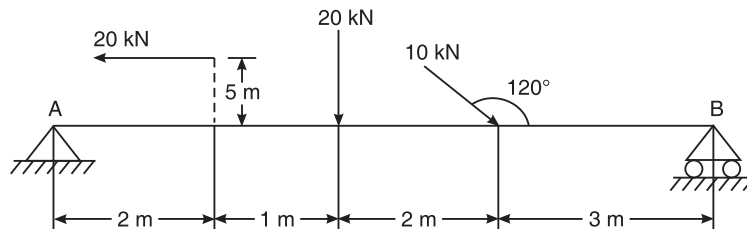

Figure 6.33 Example 6.11.

Solution Using the equilibrium conditions shown in Figure 6.34, we have

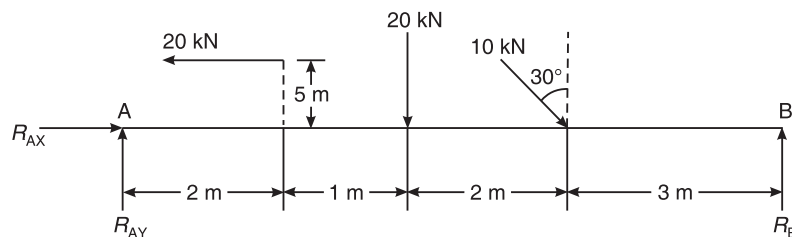

Figure 6.34 Example 6.12.

$$\begin{aligned} & \Sigma F_x = 0 \\ \text{or} & R_{AX} - 20 + 10 \sin 30^\circ = 0 \end{aligned}$$

122 ELEMENTS OF CIVIL ENGINEERING AND ENGINEERING MECHANICS

$$\therefore R_{AX} = 15 \text{ kN}$$

$$\text{Also, } \Sigma F_y = 0$$

$$\text{or } R_{AY} + R_B - 20 - 10 \cos 30^\circ = 0$$

$$\therefore R_{AY} + R_B = 28.66$$

$$\text{Also, } \Sigma M_A = 0$$

$$\therefore -20 \times 0.5 + 10 \cos 30^\circ \times 5 + 20 \times 3 - R_B \times 8 = 0$$

$$\therefore R_B = 11.663 \text{ kN}$$

Ans.

$$\therefore R_{AY} = 28.66 - 11.663 = 16.997 \text{ kN}$$

$$\therefore R_{AX} = 15 \text{ kN}$$

$$\text{or } R_A = \sqrt{(R_{AX})^2 + (R_{AY})^2}$$

$$= \sqrt{(15)^2 + (16.997)^2}$$

$$= 22.669 \text{ kN}$$

Ans.

Example 6.12 Determine the support reactions for the beam shown in Figure 6.35.

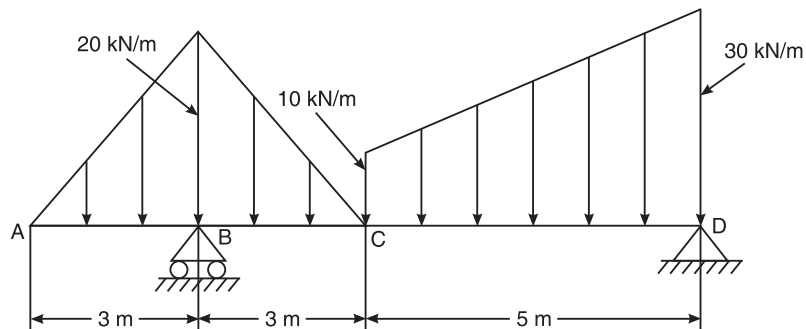

Figure 6.35 Example 6.12.

Solution First, we convert the triangular load into a point load as follows:

$$\text{Area of the triangle} = \frac{1}{2} \times 6 \times 20 = 60 \text{ kN (see Figure 6.36).}$$

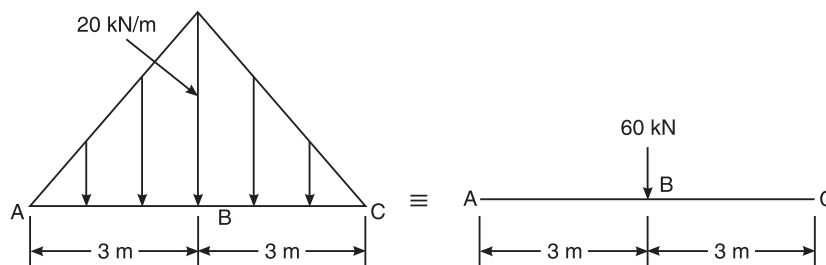

Figure 6.36 Example 6.12.

Secondly, we convert the uniformly varying load to point load as follows (Figure 6.37).

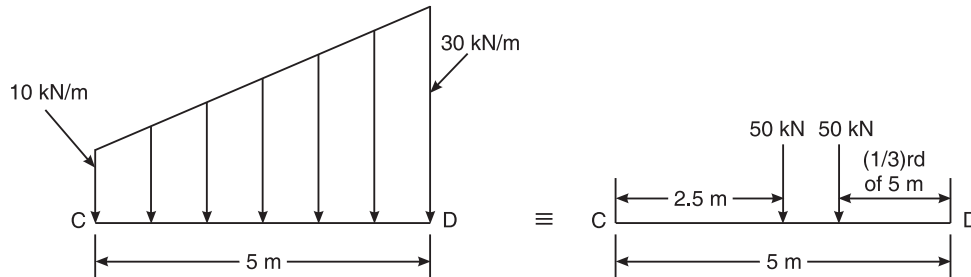

Figure 6.37 Example 6.12.

Thus, we have the loading of the beam as in Figure 6.38.

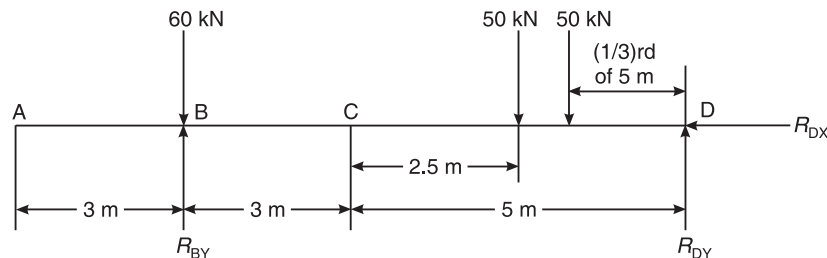

Figure 6.38 Example 6.12.

Using the conditions of equilibrium, we have

$$\begin{aligned} \Rightarrow \quad \Sigma F_x &= 0 \\ & -R_{DX} = 0 \\ \text{Also,} \quad \Sigma F_y &= 0 \\ \text{or} \quad R_{BY} + R_{DY} - 60 - 50 - 50 &= 0 \\ \text{or} \quad R_{BY} + R_{DY} &= 160 \quad (i) \\ \text{Also,} \quad \Sigma M_B &= 0 \\ \text{or} \quad -R_{DY} \times 8 + 50 \times \left(\frac{2}{3} \times 5 + 3 \right) + 50(2.5 + 3) &= 0 \\ \text{or} \quad R_{DY} &= 73.958 \text{ kN} \\ \therefore R_{BY} &= 160 - 73.958 = 86.042 \text{ kN} \quad \text{Ans.} \\ \therefore R_D &= \sqrt{R_{DX}^2 + R_{DY}^2} = \sqrt{(0)^2 + (73.958)^2} \\ \therefore R_D &= 73.958 \text{ kN} \quad \text{Ans.} \end{aligned}$$

Example 6.13 Determine the support reactions of the overhanging beam shown in Figure 6.39. VTU (January 2007)

Solution Apply the conditions of equilibrium to calculate the reactions (Figure 6.40),

$$\begin{aligned} \Sigma F_x &= 0 \\ \text{or} \quad -R_{AX} + 6 \cos 30^\circ &= 0 \end{aligned}$$

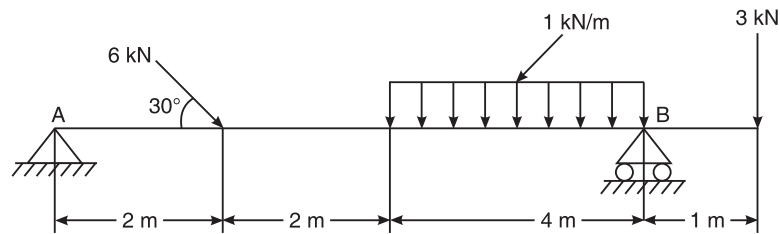

Figure 6.39 Example 6.13.

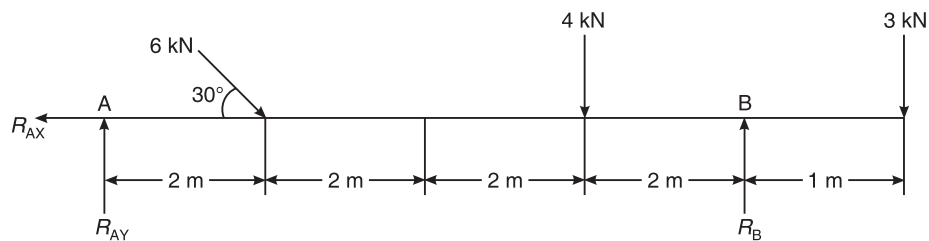

Figure 6.40 Example 6.13.

$$\therefore R_{AX} = 5.196 \text{ kN}$$

$$\text{Also, } \Sigma F_y = 0$$

$$\text{or } R_{AY} + R_B - 6 \sin 30^\circ - 4 - 3 = 0$$

$$\text{or } R_{AY} + R_B - 10 = 0 \quad (i)$$

$$\text{Also, } \Sigma M_A = 0$$

$$\text{or } -R_B \times 8 + 6 \sin 30^\circ \times 2 + 4 \times 6 + 3 \times 9 = 0$$

$$\therefore R_B = 7.125 \text{ kN} \quad \text{Ans.}$$

Substituting the value of R_B in (i), we get

$$R_{AY} + 7.125 - 10 = 0$$

$$\therefore R_{AY} = 2.875 \text{ kN}$$

$$\text{or } R_A = \sqrt{(5.196)^2 + (2.875)^2}$$

$$\therefore R_A = 5.938 \text{ kN} \quad \text{Ans.}$$

Example 6.14 Determine the reactions developed in the double overhanging beam shown in Figure 6.41.

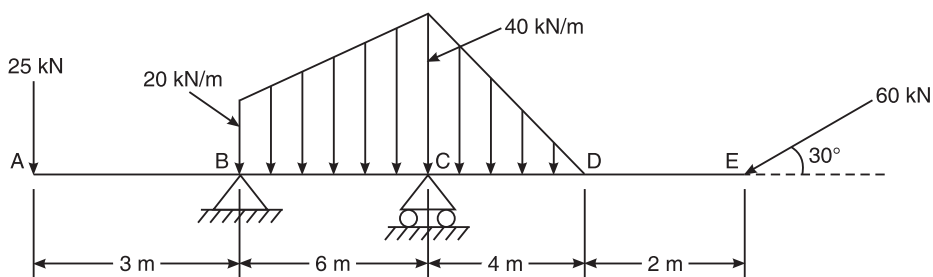

Figure 6.41 Example 6.14.

Solution Applying the conditions of equilibrium to Figure 6.42,

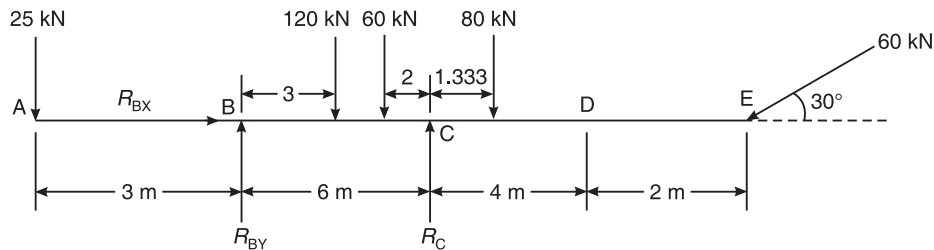

Figure 6.42 Example 6.14.

$$\Sigma F_x = 0$$

or $R_{BX} - 60 \cos 30^\circ = 0$

$\therefore R_{BX} = 51.962 \text{ kN}$

Also, $\Sigma F_y = 0$

$$R_{BY} + R_C - 25 - 120 - 60 - 80 - 60 \sin 30^\circ = 0$$

or $R_{BY} + R_C = 315$

Also, $\Sigma M_B = 0$

or $-R_C \times 6 + 60 \sin 30^\circ \times 12 + 80 \times (1.333 + 6) + 60 \times 4 + 120 \times 3 - 25 \times 3 = 0$

or $R_C = 245.273 \text{ kN}$

Ans.

$\therefore R_{BY} = 315 - 245.273 = 69.727 \text{ kN}$

or $R_B = \sqrt{(51.952)^2 + (69.727)^2}$

$\therefore R_B = 86.727 \text{ kN}$

Ans.

Example 6.15 Determine the support reactions for the compound beam shown in Figure 6.43.

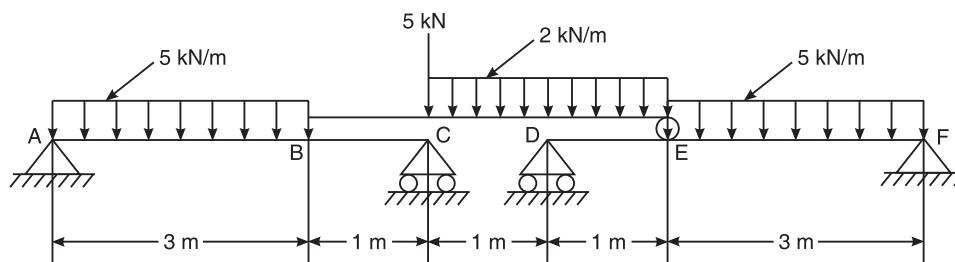

Figure 6.43 Example 6.15

Solution The radius of the roller is negligible.

Consider the beam BE (Figure 6.44(a)),

$$\Sigma F_y = 0$$

or $R_B + R_E = 9 \text{ kN}$

(i)

Also, $\Sigma M_B = 0$

$$5 \times 1 + 4 \times 2 - R_E \times 3 = 0$$

$$\text{or} \quad 3R_E = 13$$

$$\therefore R_E = \frac{13}{3} = 4.33 \text{ kN} \quad \text{Ans.}$$

$$\therefore R_B = 9 \text{ kN} - 4.333 \text{ kN} = 4.667 \text{ kN} \quad \text{Ans.}$$

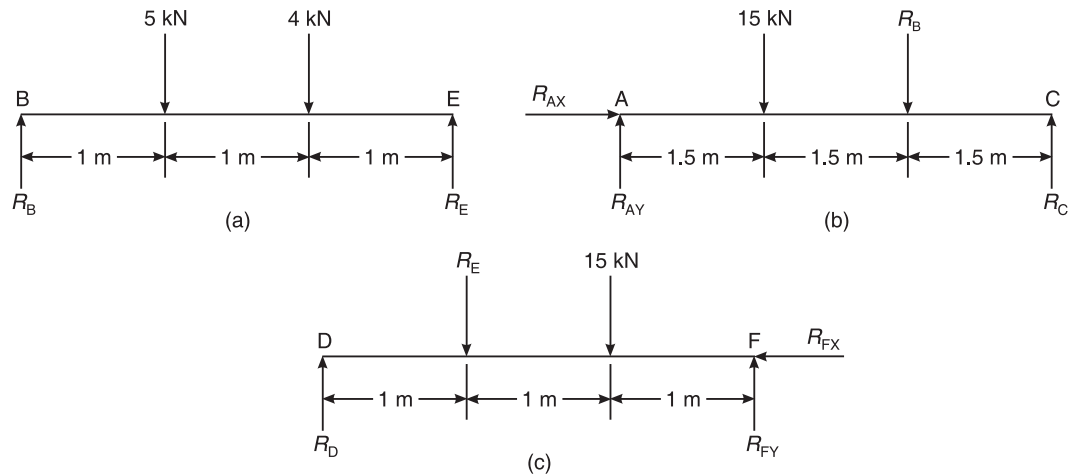

Figure 6.44 Example 6.15.

Consider the beam AC (Figure 6.44(b))

$$\Sigma F_x = 0$$

$$\therefore R_{AX} = 0$$

$$\Sigma F_y = 0$$

$$\text{or} \quad R_{AY} + R_C = 15 + 4.667 = 19.667 \text{ kN}$$

$$\text{Also,} \quad \Sigma M_A = 0$$

$$\text{or} \quad 15 \times 1.5 + 4.667 \times 3 - R_C \times 4 = 0$$

$$\text{or} \quad 4R_C = 36.501$$

$$\therefore R_C = 9.125 \text{ kN}$$

$$R_{AY} = 19.667 - 9.125 = 10.542 \text{ kN}$$

$$\therefore R_A = R_{AY} = 10.542 \text{ kN} \quad (\text{since } R_{AX} = 0) \quad \text{Ans.}$$

For beam DF (Figure 6.44(c)), we have

$$\Sigma F_x = 0$$

$$\text{or} \quad R_{FX} = 0$$

$$\text{Also,} \quad \Sigma F_y = 0$$

$$\text{or} \quad R_D + R_{FY} = 15 + 4.333 = 19.333 \text{ kN}$$

$$\text{Also,} \quad \Sigma M_F = 0$$

$$\text{or} \quad -15 \times 1.5 - 4.333 \times 3 + R_D \times 4 = 0$$

$$\therefore R_D = 8.875 \text{ kN} \quad \text{Ans.}$$

$$\therefore R_F = R_{FY} = 19.333 - 8.875 = 10.458 \text{ kN} \quad (\because R_{FX} = 0) \quad \text{Ans.}$$

Example 6.16 Calculate the tension in the string BC and the reaction at the hinged support for beam ABD in equilibrium, shown in Figure 6.45.

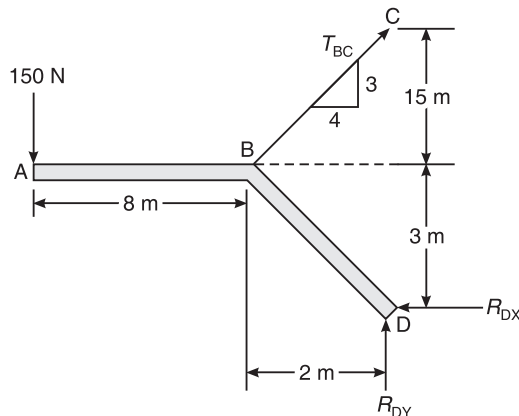

Figure 6.45 Example 6.16.

Solution Applying the conditions of equilibrium to Figure 6.45, we have

$$\Sigma F_x = 0$$

$$\text{or} \quad T_{BC} \cos 36.86^\circ - R_{DX} = 0 \quad (i)$$

$$\text{Also,} \quad \Sigma F_y = 0$$

$$-150 + T_{BC} \sin 36.86^\circ + R_{DY} = 0 \quad (ii)$$

$$\text{Also,} \quad \Sigma M_D = 0$$

$$T_{BC} \sin 36.86^\circ \times 2 + T_{BC} \cos 36.83^\circ \times 3 - R_{DX} \times 0 = 150 \times 10$$

$$\text{or} \quad 1.2 \times T_{BC} + 2.4 \times T_{BC} = 1500$$

$$\text{or} \quad T_{BC} = \frac{1500}{3.6} = 416.667 \text{ kN} \quad \text{Ans.}$$

Substituting the value of T_{BC} in (i),

$$416.667 \cos 36.86^\circ = R_{DX}$$

$$\therefore R_{DX} = 333.378 \text{ N}$$

$$\therefore R_{DY} = 150 - T_{BC} \sin 36.86^\circ$$

$$= -99.943 \text{ N}$$

$$\therefore R_D = \sqrt{(333.378)^2 + (-99.943)^2} = 348.037 \text{ N} \quad \text{Ans.}$$

Example 6.17 Calculate the reaction at the hinge and the tension for the structure shown in Figure 6.46.

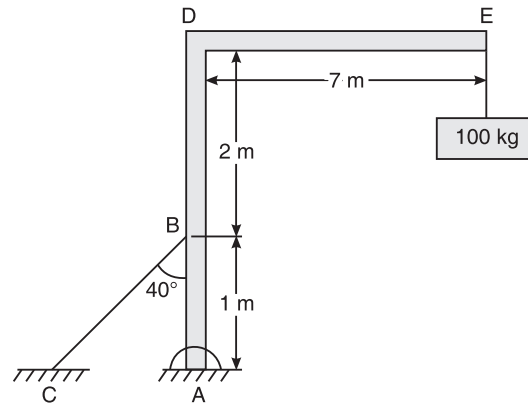

Figure 6.46 Example 6.17.

Solution Applying the conditions of equilibrium to Figure 6.47,

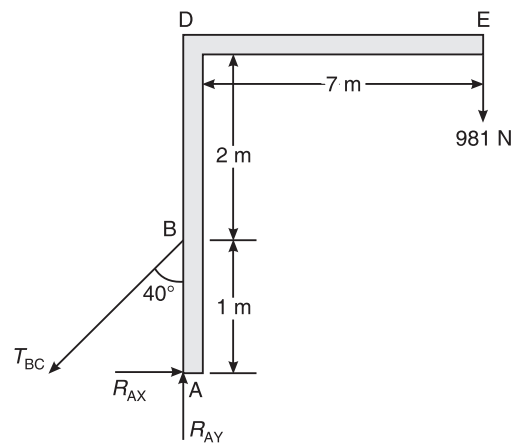

Figure 6.47 Example 6.17.

$$\Sigma F_x = 0$$

or $R_{AX} - T_{BC} \sin 40^\circ = 0$

$$\Sigma F_y = 0$$

or $-981 + R_{AY} - T_{BC} \cos 40^\circ = 0$

Also, $\Sigma M_A = 0$

or $981 \times 0.7 - T_{BC} \sin 40^\circ \times 1 = 0$

$$\therefore T_{BC} = \frac{981 \times 0.7}{\sin 40^\circ}$$

$$= 1068.316 \text{ N}$$

Ans.

$$R_{AX} = T_{BC} \sin 40 = 686.7 \text{ N}$$

$$R_{AY} = 981 + 1068.316 \cos 40^\circ$$

$$= 1799.378 \text{ N}$$

$$\therefore R_A = \sqrt{1799.378^2 + 686.7^2}$$

$$= 1925.959 \text{ N}$$

Ans.**EXERCISE PROBLEMS**

1. Calculate the support reactions for the beam loaded and supported as shown in Figure 6.48.
[Ans.: $R_A = 13 \text{ kN}$, $R_B = 16 \text{ kN}$]

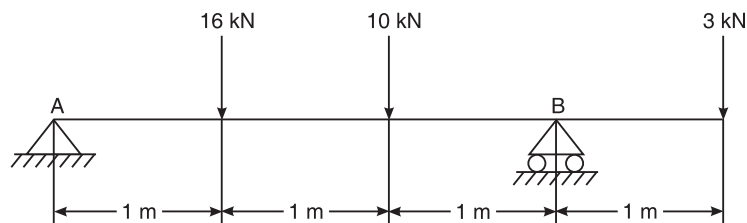
**Figure 6.48**

2. Determine the support reactions for the beam supported and loaded as shown in Figure 6.49.
[Ans.: $R_B = 32 \text{ kN}$, $R_A = 58.85 \text{ kN}$]

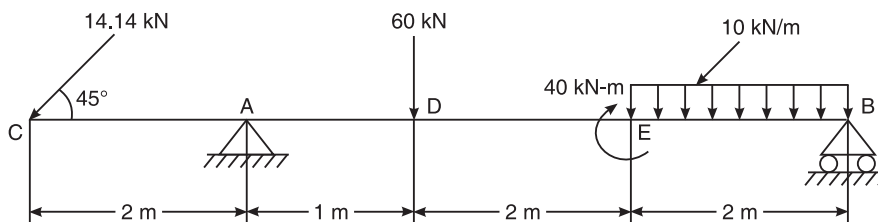
**Figure 6.49**

3. Determine the support reactions for a beam loaded as shown in Figure 6.50.
[Ans.: $R_A = 55.83 \text{ kN}$, $R_E = 79.17 \text{ kN}$]

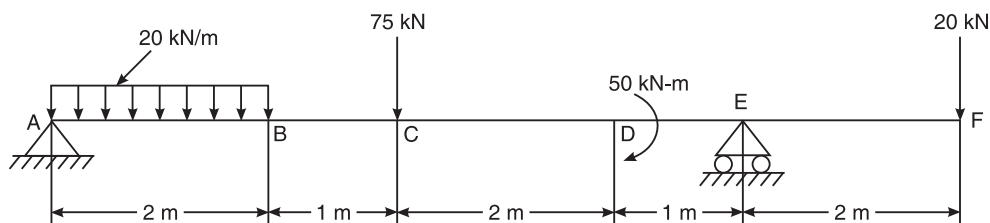
**Figure 6.50**

130 ELEMENTS OF CIVIL ENGINEERING AND ENGINEERING MECHANICS

4. A horizontal beam 6 m long is supported on a knife edge at its end B and the end A, rests on a roller support placed on an inclined plane, having an inclination of 30° as shown in Figure 6.51. Find the reactions at the supports A and B.

[Ans.: $R_A = 1667.44 \text{ N}$, $R_B = 1696.17 \text{ N}$]

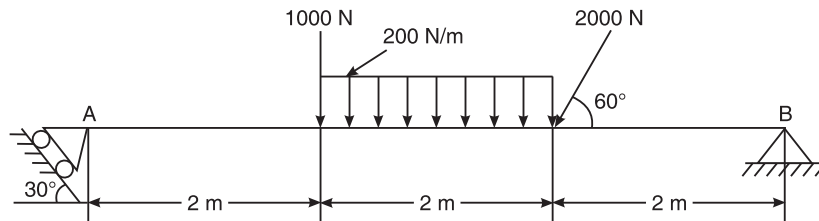

Figure 6.51

5. Find the magnitude of anticlockwise couple M to be applied at D so that reaction at F will be 35 kN upwards. Also find the reaction at support B of beam as shown in Figure 6.52.

[Ans.: $M = 18.75 \text{ N}$, $R_B = 50 \text{ kN}$]

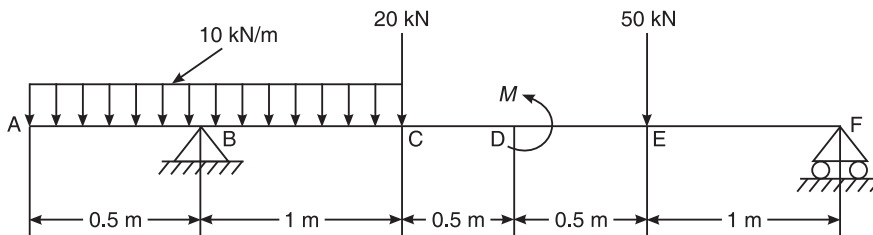

Figure 6.52

6. Find the support reactions for a beam loaded and supported as shown in Figure 6.53.

[Ans.: $R_{AX} = 5 \text{ kN}$, $R_{AY} = 1.17 \text{ kN}$, $R_B = 16.83 \text{ kN}$]

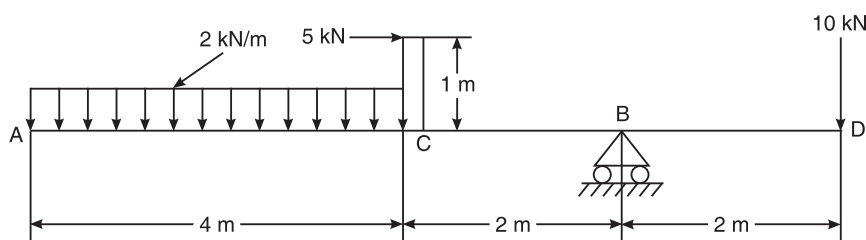

Figure 6.53

7. Compute the reactions at the supports of beam ABCD which is loaded and supported as shown in Figure 6.54. [Ans.: $R_{CX} = 50.558 \text{ kN}$, $R_A = 26.462 \text{ kN}$, $R_{CY} = 84.096 \text{ kN}$]

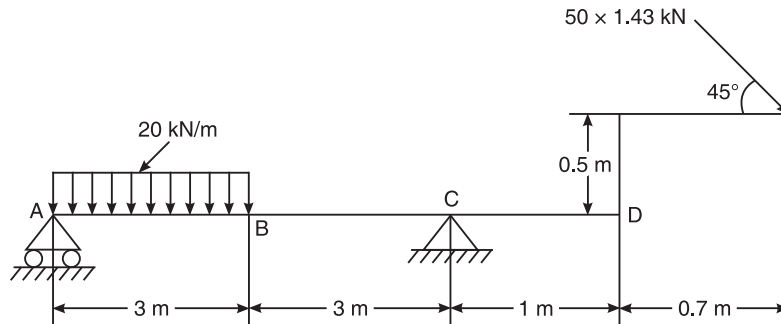

Figure 6.54

8. A beam ABF is loaded and supported as shown in Figure 6.55. Find the direction and magnitude of the couple to be applied at D so that the reaction at F will be 50 kN upwards. Also compute the reaction at the F support. [Ans.: Couple at D = 18.75 kN, $R_F = 35 \text{ kN}$]

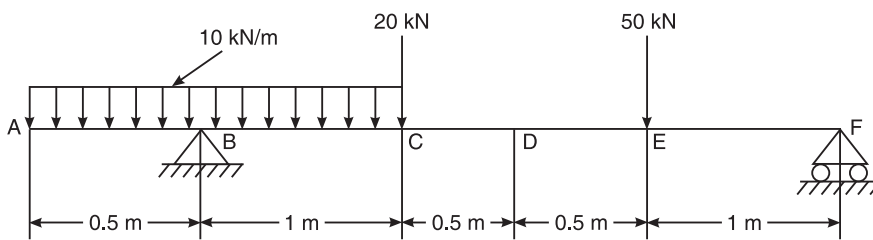

Figure 6.55

ENGINEERING STRUCTURE

The Engineering structures are mainly classified into three types. They are:

- (i) Trusses (ii) Frames (iii) Machines

Plane trusses are those structures in which all members are lying in a single plane. Plane trusses are made of several bars or members connected together at the joints by riveting or welding to form a rigid formwork, and also support stationary loads or moving loads. Individual members of a truss is a two force member subjected to either tension or compression. The forces are acting only on the joints.

Classification of Trusses

The trusses are classified into three types which are depicted in Figure 7.1.

Rigid truss or perfect truss

A rigid truss is one in which the number of members are sufficient to resist the external loads, and in which deformation is very small. The relationship between the number of members and number of joints is given by

$$m = 2j - 3$$
$$5 = 2 \times 4 - 3 = 5$$

Hence, it is rigid truss.

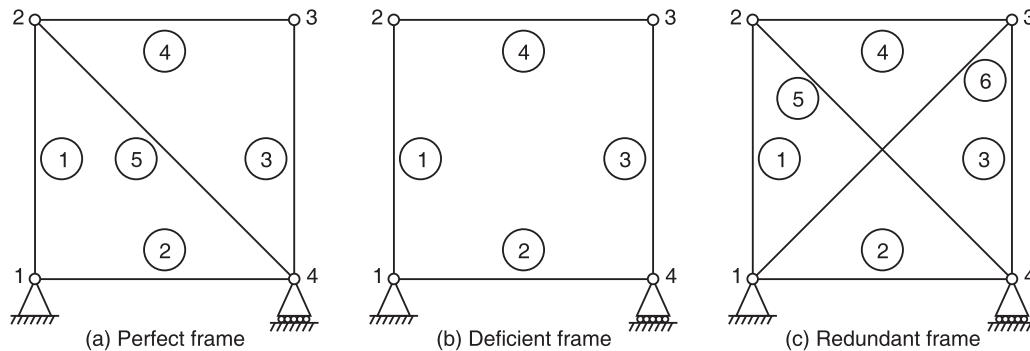

Figure 7.1 Types of truss.

Non-rigid truss or deficient truss

A non-rigid truss is one in which the number of members are less than that required for a perfect truss. The relationship between the number of members and number of joints is given by

$$m < 2j - 3$$

$$4 < 2 \times 4 - 3$$

$$4 < 5$$

Hence, it is non-rigid truss.

Over rigid truss or redundant truss

An over rigid truss is one in which the number of members are more than that required for a perfect truss. The relationship between the number of members and number of joints is given by

$$m > 2j - 3$$

$$6 > 2 \times 4 - 3$$

$$6 > 5$$

Hence, it is an over rigid truss.

The following are the assumptions made in the analysis of statically determinate trusses:

1. The members of trusses are straight.
2. The cross section of members is uniform.
3. Forces are acting only on joints.
4. All members are pin-jointed members.
5. All members are rigid.
6. All members of trusses are two force members subjected to either equal and opposite tension or compression.

Analysis of Statically Determinate Trusses

Plane trusses can be analysed by method of joints and method of sections

Method of joints

Analysis of truss mainly consists of calculations of support reactions and determination of internal forces induced in the internal members of a truss. The method of joints or joint method is a method

134 ELEMENTS OF CIVIL ENGINEERING AND ENGINEERING MECHANICS

in which the equilibrium of individual joints are considered, and this method is useful in finding the forces in all members of a truss.

The various steps involved in the method of joints are as follows:

1. Check whether the given truss is statically determinate or indeterminate.
2. Calculate the support reactions by considering the equilibrium of entire truss.
3. Now, consider a joint with minimum number of unknowns (maximum of 2 unknowns, because only two conditions of equilibrium are available namely $\Sigma F_x = 0$ and $\Sigma F_y = 0$).
4. Initially assume that all members under consideration are in tension (arrow head away from the joint is positive).
5. Apply the conditions of equilibrium and by solving the equilibrium, determine the unknown forces in the members.
6. If the result works out to be positive then our assumption is right, if it is negative then our assumption is wrong and it indicates that particular member is under compression, so that reverse the direction of force while considering it in the next joint.
7. Same procedure has to be followed for other joints to determine the internal forces in the remaining members of a truss.
8. Note down the results in a tabular format in the table given below:

| S. no. | Member | Magnitude | Nature of force |
|--------|--------|-----------|-----------------|
| | | | |

1. Now, let us take the figures one by one and analyse the trusses. Analyse the truss in Figure 7.2(a) by the method of joints.

$$\begin{aligned}
 n &= n_e + n_i \\
 &= (R - r) + [m - (2j - 3)] \\
 &= (3 - 3) + (9 - \{2(6) - 3\}) \\
 n &= 0 + 0 = 0
 \end{aligned}$$

Hence, the given truss is statically determinate.

Calculation of support reactions:

$$\begin{aligned}
 \Rightarrow \quad \Sigma F_x &= 0 \\
 R_{F_x} &= 0 \\
 \Sigma F_y &= 0 \\
 \Rightarrow \quad R_A + R_{F_y} - 1000 - 1000 &= 0 \\
 R_A + R_{F_y} &= 2000 \\
 \Sigma M_A &= 0
 \end{aligned} \tag{7.1}$$

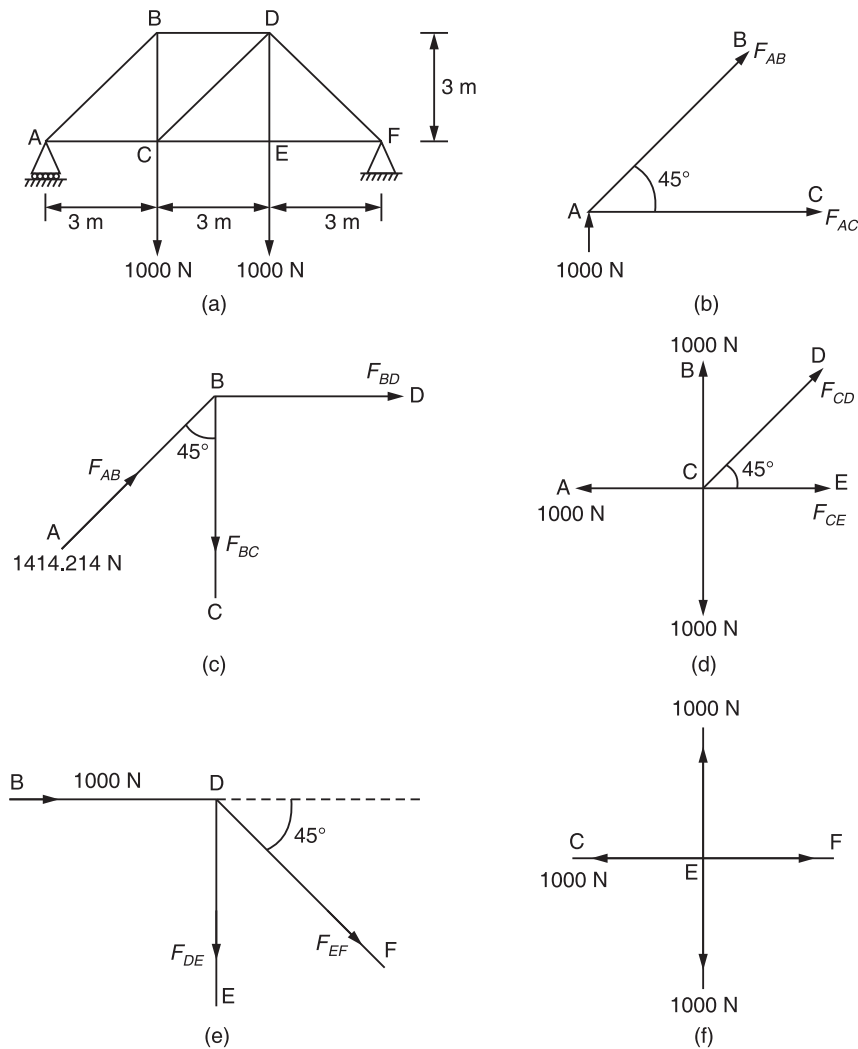

Figure 7.2

$$\begin{aligned} \Rightarrow 1000 \times 3 + 1000 \times 6 - R_{F_y} \times 9 &= 0 \\ R_{F_y} \times 9 &= 9000 \\ \Rightarrow R_{F_y} &= 1000 \text{ N} \\ \therefore R_A &= 2000 - 1000 = 1000 \text{ N} \end{aligned}$$

Consider joint A [Figure 7.2(b)] which has got minimum number of unknowns, i.e. 2

$$\angle BAC = \tan^{-1}\left(\frac{3}{3}\right) = 45^\circ$$

Assume that the members AB & AC are under tension.

136 ELEMENTS OF CIVIL ENGINEERING AND ENGINEERING MECHANICS

Apply the conditions of equilibrium

$$\begin{aligned} \Rightarrow \quad \Sigma F_y &= 0 \\ 1000 + F_{AB} \sin 45^\circ &= 0 \\ F_{AB} &= -1414.214 \text{ N (C)} \end{aligned}$$

The negative sign indicates that, the member AB is under compression.

$$\begin{aligned} \Rightarrow \quad \Sigma F_x &= 0 \\ F_{AC} + F_{AB} \cos 45^\circ &= 0 \\ F_{AC} &= 1414.214 \cos 45^\circ \\ &= 1000 \text{ N (T)} \end{aligned}$$

\therefore Our assumption is right.

Consider joint B [Figure 7.2(c)]

$$\begin{aligned} \Rightarrow \quad \Sigma F_x &= 0 \\ 1414.214 \sin 45^\circ + F_{BD} &= 0 \\ F_{BD} &= -1000 \text{ N(C)} \end{aligned}$$

\therefore Member BD is under compression

$$\begin{aligned} \Rightarrow \quad \Sigma F_y &= 0 \\ 1414.214 \cos 45^\circ - F_{BC} &= 0 \\ F_{BC} &= -1000 \text{ N(T)} \end{aligned}$$

\therefore Our assumption is right.

Consider joint C [Figure 7.2(d)]

$$\begin{aligned} \Rightarrow \quad \Sigma F_y &= 0 \\ 1000 - 1000 + F_{CD} \sin 45^\circ &= 0 \\ \Rightarrow \quad F_{CD} &= 0 \\ \Rightarrow \quad \Sigma F_x &= 0 \\ F_{CE} - 1000 + F_{CD} \cos 45^\circ &= 0 \\ F_{CE} &= 1000 \text{ N(T)} \end{aligned}$$

\therefore Our assumption is right.

Consider joint D [Figure 7.2(e)]

$$\begin{aligned} \Rightarrow \quad \Sigma F_x &= 0, 1000 + F_{DF} \cos 45^\circ = 0 \\ F_{DF} &= -1414.214 \text{ N(C)} \\ \Rightarrow \quad \Sigma F_y &= 0 \\ -F_{DE} - F_{DF} \sin 45^\circ &= 0 \\ F_{DE} &= 1414.214 \sin 45^\circ = 1000 \text{ N(T)} \end{aligned}$$

Consider joint E [Figure 7.2(f)]

$$\begin{aligned} \Rightarrow \quad \Sigma F_x &= 0 \\ F_{EF} - 1000 &= 0 \\ F_{EF} &= 1000 \text{ N(T)} \end{aligned}$$

The analysis is tabulated as follows:

| S. no. | Member | Magnitude of force (N) | Nature of force |
|--------|--------|------------------------|-----------------|
| 1 | AB | 1414.214 | Compression |
| 2 | BC | 1000 | Tension |
| 3 | AC | 1000 | Tension |
| 4 | BD | 1000 | Compression |
| 5 | CE | 1000 | Tension |
| 6 | CD | 0 | — |
| 7 | DE | 1000 | Tension |
| 8 | DF | 1414.214 | Compression |
| 9 | EF | 1000 | Tension |

2. Analyse the truss shown in Figure 7.3 by the method of joints. Tabulate the result and indicate the nature of force in the truss.

$$\begin{aligned}
 n &= n_e + n_i \\
 &= (R - r) + [m - (2j - 3)] \\
 &= (3 - 3) + [9 - 2(6) - 3] \\
 &= 0 + (9 - 9) \\
 n &= 0
 \end{aligned}$$

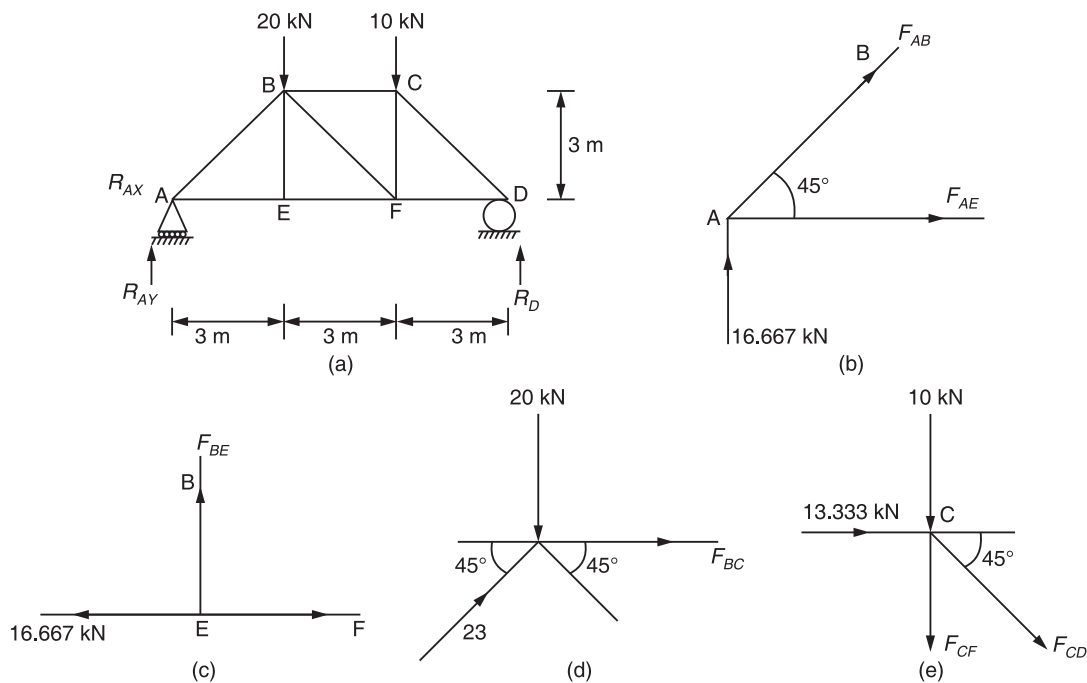

Figure 7.3

138 ELEMENTS OF CIVIL ENGINEERING AND ENGINEERING MECHANICS

Hence, the given truss is statically determinate.

$$\begin{aligned}
 \Rightarrow \quad & \Sigma F_x = 0 \\
 & R_{Ax} = 0 \\
 & \Sigma F_y = 0 \\
 \Rightarrow \quad & R_{Ay} + R_D - 20 - 10 = 0 \\
 & R_{Ay} + R_D = 30 \text{ kN} \\
 & \Sigma M_A = 0 \\
 \Rightarrow \quad & -R_D \times 9 + 10 \times 6 + 20 \times 3 = 0 \\
 & R_D \times 9 = 120 \\
 \text{or} \quad & R_D = 13.333 \text{ kN} \\
 \therefore \quad & R_{Ay} = 30 - 13.333 = 16.667 \text{ kN}
 \end{aligned} \tag{7.2}$$

Consider a joint A with minimum number of unknowns [i.e. 2]

$$\angle BAE = \tan^{-1}\left(\frac{3}{3}\right) = 45^\circ$$

Applying conditions of equilibrium, we get

$$\begin{aligned}
 \Sigma F_y = 0 \\
 \text{i.e.} \quad 16.667 + F_{AB} \sin 45^\circ = 0 \\
 F_{AB} = -23.570 \text{ kN (C)}
 \end{aligned}$$

i.e. member AB is under compression

$$\begin{aligned}
 \Sigma F_x = 0; \\
 F_{AE} + F_{AB} \cos 45^\circ = 0 \\
 F_{AE} = 16.667 \text{ kN (T)}
 \end{aligned}$$

\therefore Our assumption is right.

Consider joint E

Applying conditions of equilibrium

$$\begin{aligned}
 \Sigma F_x = 0 \\
 F_{EF} = 16.667 \text{ kN (T)} \\
 \Sigma F_y = 0 \\
 \Rightarrow \quad F_{BE} = 0
 \end{aligned}$$

Consider joint B

$$\begin{aligned}
 \Sigma F_x = 0 \\
 23.57 \cos 45^\circ + F_{BC} + F_{BF} \cos 45^\circ = 0 \\
 \Sigma F_y = 0 \\
 23.57 \sin 45^\circ - F_{BF} \sin 45^\circ - 20 = 0 \\
 F_{BF} = -4.714 \text{ kN (C)} \\
 \therefore \quad F_{BC} = -13.333 \text{ kN (C)}
 \end{aligned}$$

Consider joint C

$$\begin{aligned}\Sigma F_x &= 0 \\ F_{CD} \cos 45^\circ + 13.333 &= 0 \\ F_{CD} &= -18.856 \text{ kN (C)} \\ \Sigma F_y &= 0 \\ -10 - F_{CF} - F_{CD} \sin 45^\circ &= 0 \\ F_{CF} &= 3.333 \text{ kN (T)}\end{aligned}$$

Consider joint F

$$\begin{aligned}\Sigma F_x &= 0 \\ F_{FD} - 16.667 + 4.714 \cos 45^\circ &= 0 \\ F_{FD} &= 13.333 \text{ kN (T)}\end{aligned}$$

| S. no. | Member | Magnitude of force (N) | Nature of force |
|--------|--------|------------------------|-----------------|
| 1. | AB | 23.570 | Compression |
| 2. | AE | 16.667 | Tension |
| 3. | BC | 13.333 | Compression |
| 4. | BE | 0 | — |
| 5. | BF | 4.714 | Compression |
| 6. | CD | 18.856 | Compression |
| 7. | CF | 3.333 | Tension |
| 8. | DF | 13.333 | Tension |
| 9. | EF | 16.667 | Tension |

3. Analyse the truss shown in Figure 7.4 by the method of joints.

$$\begin{aligned}n &= n_e + n_i \\ &= (R - r) + [m - (2j - 3)] \\ &= (3 - 3) + [13 - (2 \times 8 - 3)] \\ &= 0 + (13 - 13) \\ &= 0\end{aligned}$$

Hence, the given truss is statically determinate.

Calculation of support reactions

$$\begin{aligned}\Sigma F_x &= 0 \\ R_{AX} &= 0 \\ \Sigma F_y &= 0; R_{Ay} + R_E - 20 - 30 - 30 = 0 \\ R_{Ay} + R_E &= 80 \\ \Sigma M_A &= 0 \\ 20 \times 3 + 30 \times 6 + 30 \times 9 - R_E \times 12 &= 0 \\ R_E &= 42.5 \text{ kN} \\ R_{Ay} &= 80 - 42.5 = 37.5 \text{ kN}\end{aligned} \tag{7.3}$$

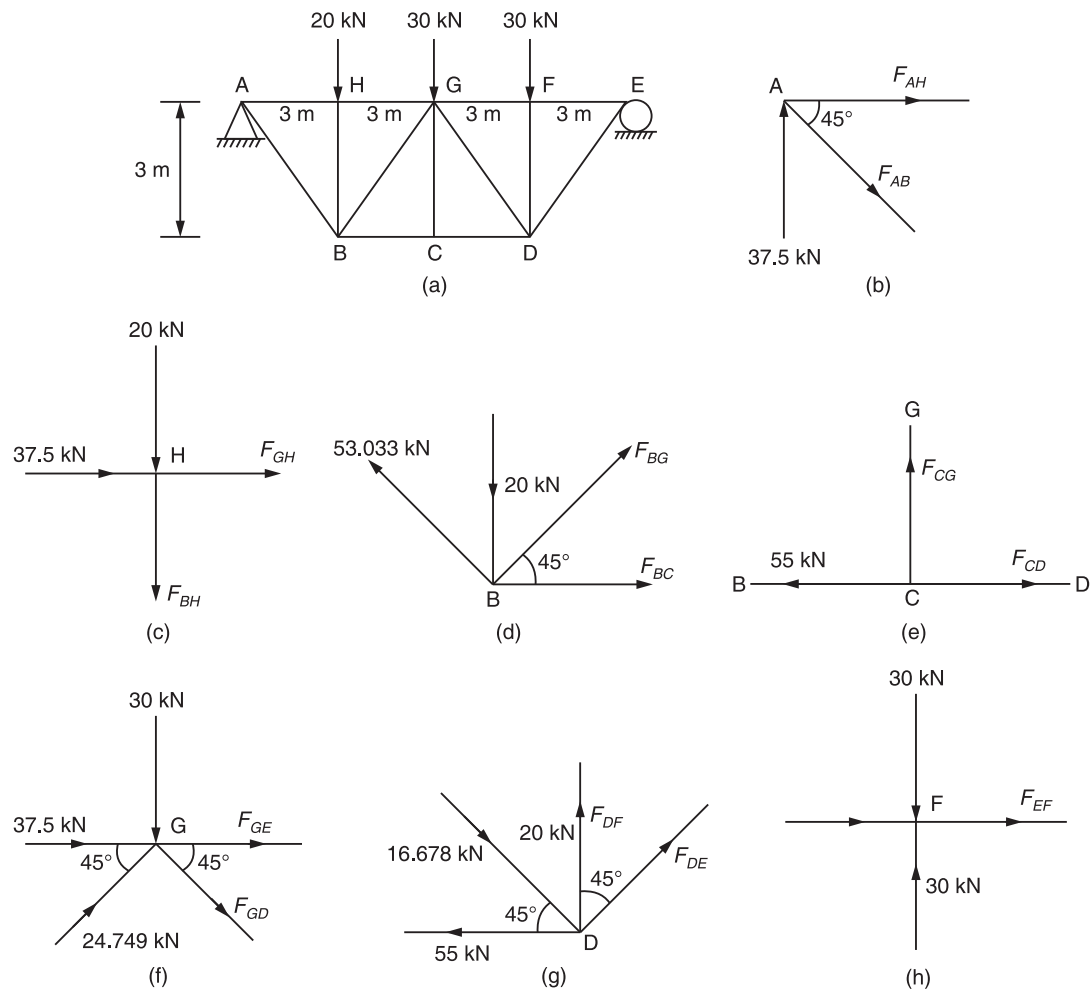

Figure 7.4

Consider joint A, with minimum number of unknowns [i.e. 2],

$$\angle HAB = \tan^{-1}\left(\frac{3}{3}\right) = 45^\circ$$

Applying conditions of equilibrium, we get

$$\begin{aligned}\Sigma F_y &= 0; \\ 37.5 - F_{AB} \sin 45^\circ &= 0 \\ F_{AB} &= 53.033 \text{ kN(T)} \\ \Sigma F_x &= 0 \\ F_{AH} + F_{AB} \cos 45^\circ &= 0 \\ F_{AH} &= -37.5 \text{ kN (C)}\end{aligned}$$

Consider joint H

$$\begin{aligned}\Sigma F_x &= 0 \\ F_{GH} + 37.5 &= 0 \\ F_{GH} &= -37.5 \text{ kN (C)} \\ \Sigma F_y &= 0 \\ -F_{BH} - 20 &= 0 \\ F_{BH} &= -20 \text{ kN (C)}\end{aligned}$$

Consider joint B

$$\begin{aligned}\Sigma F_y &= 0 \\ F_{BG} \sin 45^\circ - 20^\circ + 53.033 \sin 45^\circ &= 0 \\ F_{BG} &= -24.749 \text{ kN (C)} \\ \Sigma F_x &= 0 \\ F_{BC} + F_{BG} \cos 45^\circ - 53.033 \cos 45^\circ &= 0 \\ F_{BC} &= 55 \text{ kN (T)}\end{aligned}$$

Consider joint C

$$\begin{aligned}\Sigma F_x &= 0 \\ F_{CD} &= 55 \text{ kN (T)} \\ \Sigma F_y &= 0 \\ F_{CG} &= 0\end{aligned}$$

Consider joint G

$$\begin{aligned}\Sigma F_y &= 0 \\ 24.749 \sin 45^\circ - F_{GD} \sin 45^\circ - 30 &= 0 \\ F_{GD} &= -17.678 \text{ kN (C)} \\ \Sigma F_x &= 0 \\ F_{GF} + F_{GD} \cos 45^\circ + 24.749 \cos 45^\circ + 37.5 &= 0 \\ F_{GF} &= -42.5 \text{ kN (C)}\end{aligned}$$

Consider joint D

$$\begin{aligned}\Sigma F_x &= 0 \\ F_{DE} \sin 45^\circ - 55 + 17.678 \cos 45^\circ &= 0 \\ F_{DE} &= 60.104 \text{ kN (T)} \\ \Sigma F_y &= 0 \\ F_{DF} - 17.678 \sin 45^\circ + 60.104 \cos 45^\circ &= 0 \\ F_{DF} &= -30 \text{ kN (C)}\end{aligned}$$

Consider joint F

$$\begin{aligned}\Sigma F_x &= 0 \\ F_{EF} - 42.5 &= 0 \\ F_{EF} &= -42.5 \text{ kN (C)}\end{aligned}$$

142 ELEMENTS OF CIVIL ENGINEERING AND ENGINEERING MECHANICS

| S. no. | Member | Magnitude (N) | Nature of force |
|--------|--------|---------------|-----------------|
| 1. | AB | 53.033 | Tension |
| 2. | AH | 37.5 | Compression |
| 3. | BH | 20 | Compression |
| 4. | BC | 55 | Tension |
| 5. | BG | 24.749 | Compression |
| 6. | CD | 55 | Tension |
| 7. | CG | 0 | — |
| 8. | DE | 60.104 | Tension |
| 9. | DF | 30 | Compression |
| 10. | DG | 17.678 | Compression |
| 11. | EF | 42.5 | Compression |
| 12. | FG | 42.5 | Compression |
| 13. | GH | 37.5 | Compression |

4. Analyse the truss shown in Figure 7.5 by the method of joints and indicate the member forces on a neat sketch of the truss.

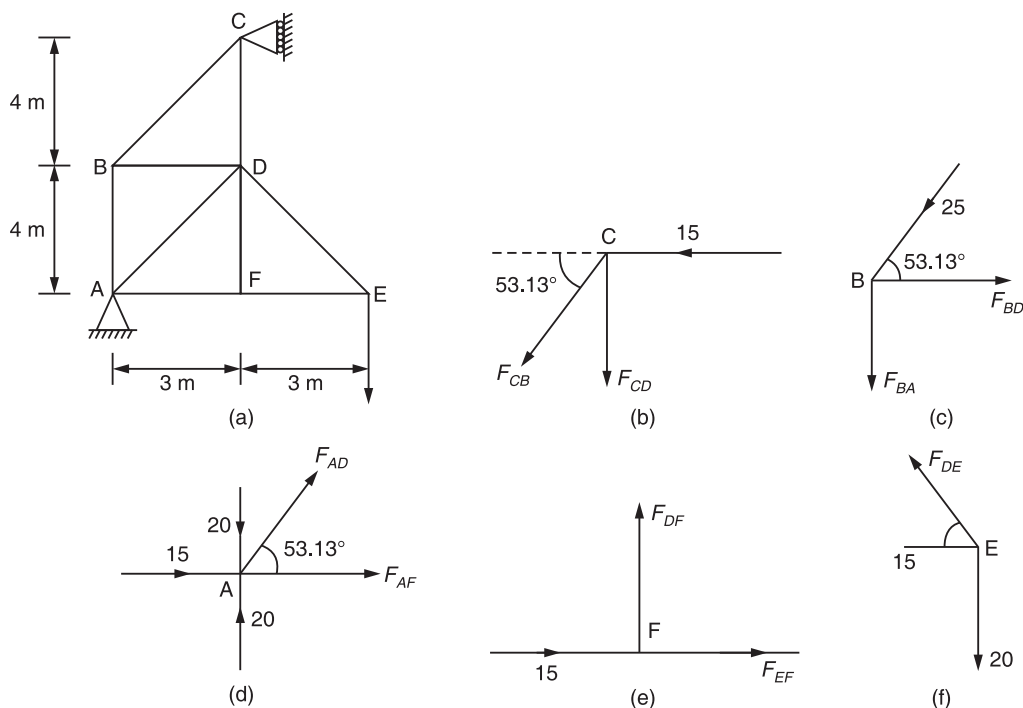

Figure 7.5

$$\begin{aligned}
 n &= n_e + n_i \\
 &= (R - r) + [m - (2j - 3)] \\
 &= (3 - 3) + [9 - (2(6) - 3)] \\
 &= 0 + (9 - 9) \\
 &= 0
 \end{aligned}$$

Given truss is determinate

$$\begin{aligned}
 \Sigma F_x &= 0 \\
 R_C - R_{AX} &= 0 \\
 R_C &= R_{AX} \\
 \Sigma F_y &= 0 \\
 R_{AY} &= 20 \text{ kN} \\
 \Sigma M_A &= 0 \\
 20 \times 6 - R_C \times 8 &= 0 \\
 R_C &= 15 \text{ kN} \\
 \therefore R_{AX} &= 15 \text{ kN}
 \end{aligned} \tag{7.4}$$

Consider joint C

$$\begin{aligned}
 \Sigma F_x &= 0 \\
 -F_{CB} \cos 53.13^\circ - 15 &= 0 \\
 \Rightarrow F_{CB} &= -25 \text{ kN (C)} \\
 \Sigma F_y &= 0 \\
 -F_{CD} - F_{CB} \sin 53.13^\circ &= 0 \\
 \Rightarrow F_{CD} &= -20 \text{ kN (T)}
 \end{aligned}$$

Consider joint B

$$\begin{aligned}
 \Sigma F_x &= 0 \\
 F_{BD} - 25 \cos 53.13^\circ &= 0 \\
 \Rightarrow F_{BD} &= 15 \text{ kN (T)} \\
 \Sigma F_y &= 0 \\
 -25 \sin 53.13^\circ - F_{BA} &= 0 \\
 \Rightarrow F_{BA} &= -20 \text{ kN (C)}
 \end{aligned}$$

Consider joint A

$$\begin{aligned}
 \Sigma F_y &= 0 \\
 F_{AD} \sin 53.13^\circ - 20 + 20 &= 0 \\
 F_{AD} &= 0 \\
 \Sigma F_x &= 0 \\
 F_{AF} + F_{AD} \cos 53.13^\circ + 15 &= 0 \\
 F_{AF} &= -15 \text{ kN (C)}
 \end{aligned}$$

144 ELEMENTS OF CIVIL ENGINEERING AND ENGINEERING MECHANICS

Consider joint F

$$\begin{aligned} \Rightarrow \quad \Sigma F_y &= 0 \\ F_{DF} &= 0 \\ \Sigma F_x &= 0 \\ F_{EF} &= -15 \text{ kN (C)} \end{aligned}$$

Consider joint E

$$\begin{aligned} \Sigma F_x &= 0 \\ -F_{DE} \cos 53.13^\circ + 15 &= 0 \\ F_{DE} &= 25 \text{ kN (T)} \end{aligned}$$

| S. no. | Member | Magnitude of force (N) | Nature of force |
|--------|--------|------------------------|-----------------|
| 1 | AB | 20 | Compression |
| 2 | AD | 0 | — |
| 3 | AF | 15 | Compression |
| 4 | BC | 25 | Compression |
| 5 | BD | 15 | Tension |
| 6 | CD | 20 | Tension |
| 7 | DE | 25 | Tension |
| 8 | DF | 0 | — |
| 9 | EF | 15 | Compression |

5. Determine the forces in the members of truss as shown in Figure 7.6(a) by the method of joints.

$$\begin{aligned} n &= n_e + n_i \\ &= (R - r) + (m - 2j - 3) \\ &= (3 - 3) + 11 - [2(7) - 3] \\ &= 0 + (11 - 11) \\ &= 0 \end{aligned}$$

Calculation of support reactions

$$\begin{aligned} \Sigma F_x &= 0 \\ R_{Ex} - 10 \cos 60^\circ - 20 \cos 60^\circ - 10 \cos 60^\circ &= 0 \\ R_{Ex} &= +20 \text{ kN} \\ \Sigma F_y &= 0 \\ R_{Ey} + R_A - 10 \sin 60^\circ - 20 \sin 60^\circ - 10 \sin 60^\circ &= 0 \\ R_{Ey} + R_A &= 34.641 \quad (7.5) \\ \Sigma M_E &= 0 \\ R_A \times 9 - 20 \times 2.6 - 10 \times 5.2 &= 0 \\ R_A &= 11.556 \text{ kN} \\ \therefore R_{Ey} &= 23.085 \text{ kN} \end{aligned}$$

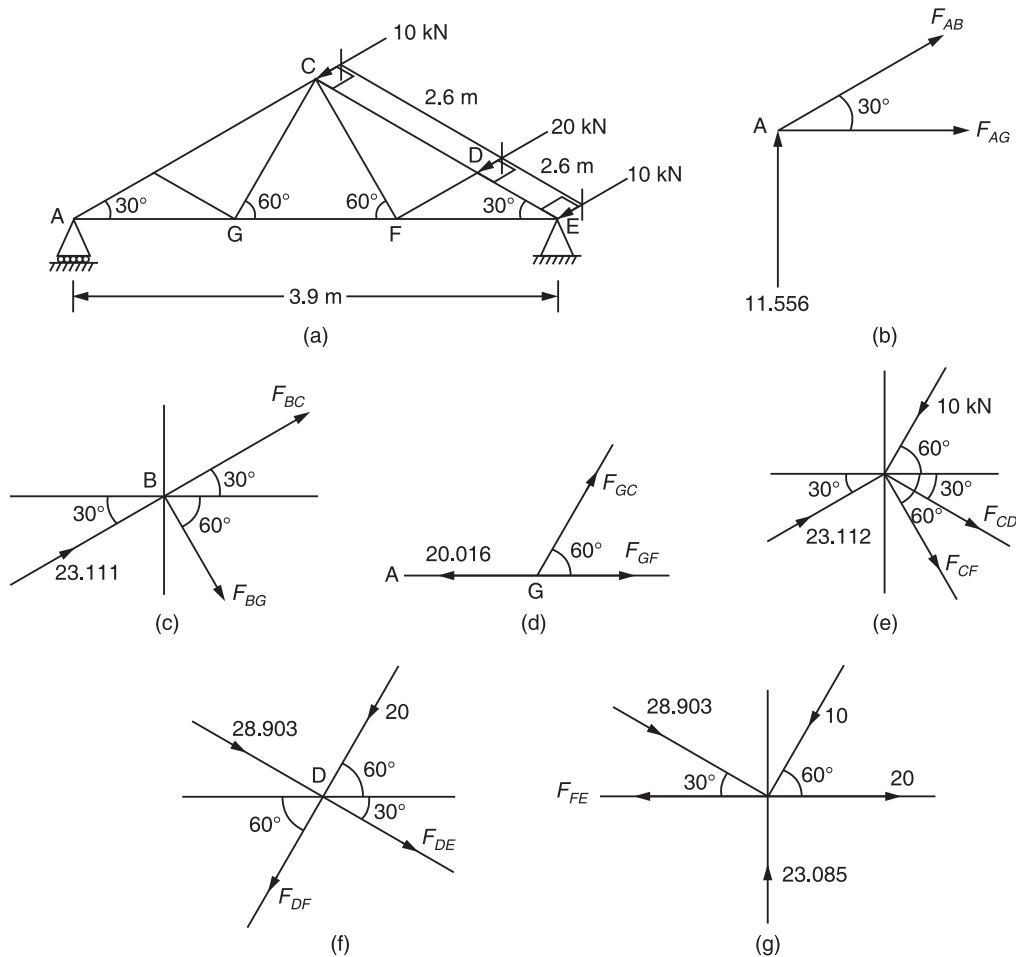

Figure 7.6

Consider joint A

$$\begin{aligned} \Sigma F_y &= 0 \\ F_{AB} \sin 30^\circ + 11.556 &= 0 \\ \Rightarrow F_{AB} &= -23.112 \text{ kN (C)} \\ \Sigma F_x &= 0 \\ F_{AG} + F_{AB} \cos 30^\circ &= 0 \\ \Rightarrow F_{AG} &= 20.016 \text{ kN (T)} \end{aligned}$$

Consider joint B

$$\begin{aligned} \Sigma F_x &= 0 \\ 23.112 \cos 30^\circ + F_{BC} \cos 30^\circ + F_{BG} \cos 60^\circ &= 0 \\ F_{BC} \cos 30^\circ + F_{BG} \cos 60^\circ &= -23.112 \cos 30^\circ \end{aligned}$$

146 ELEMENTS OF CIVIL ENGINEERING AND ENGINEERING MECHANICS

$$\begin{aligned}\Sigma F_y &= 0 \\ 23.112 \sin 30^\circ + F_{BC} \sin 30^\circ - F_{BG} \sin 60^\circ &= 0 \\ F_{BC} \sin 30^\circ - F_{BG} \sin 60^\circ &= -23.112 \sin 30^\circ \\ \therefore F_{BC} &= -23.112 \text{ kN (C)} \\ F_{BG} &= 0\end{aligned}$$

Consider joint G

$$\begin{aligned}\Sigma F_y &= 0 \\ F_{GC} \sin 60^\circ &= 0 \\ F_{GC} &= 0 \\ \Sigma F_x &= 0 \\ F_{GF} - 20.016 &= 0 \\ F_{GF} &= 20.016 \text{ kN (T)}\end{aligned}$$

Consider joint C

$$\begin{aligned}\Sigma F_x &= 0 \\ 23.112 \cos 30^\circ - 10 \cos 60^\circ + F_{CD} \cos 30^\circ + F_{CF} \cos 60^\circ &= 0 \\ F_{CD} \cos 30^\circ + F_{CF} \cos 60^\circ &= 10 \cos 60^\circ - 23.112 \cos 30^\circ \\ \Sigma F_y &= 0 \\ 23.112 \sin 30^\circ - 10 \sin 60^\circ - F_{CD} \sin 30^\circ - F_{CF} \sin 60^\circ &= 0 \\ \text{or } F_{CD} \sin 30^\circ + F_{CF} \sin 60^\circ &= 23.112 \sin 30^\circ - 10 \sin 60^\circ \\ F_{CD} &= -28.903 \text{ kN (C)} \\ F_{CF} &= 20.031 \text{ kN (T)}\end{aligned}$$

Consider joint D

$$\begin{aligned}\Sigma F_x &= 0 \\ F_{DE} \cos 30^\circ - F_{DF} \cos 60^\circ + 28.903 \cos 30^\circ - 20 \cos 60^\circ &= 0 \\ F_{DE} \cos 30^\circ - F_{DF} \cos 60^\circ &= -15.031 \\ \Sigma F_y &= 0 \\ -F_{DE} \sin 30^\circ - F_{DF} \sin 60^\circ - 28.903 \sin 30^\circ - 20 \sin 60^\circ &= 0 \\ F_{DE} \sin 30^\circ + F_{DF} \sin 60^\circ &= -31.772 \\ \therefore F_{DE} &= -28.903 \text{ kN (C)} \\ F_{DF} &= -20 \text{ kN (C)}\end{aligned}$$

Consider joint E

$$\begin{aligned}\Sigma F_x &= 0 \\ -F_{FE} + 28.903 \cos 30^\circ - 10 \cos 60^\circ + 20 &= 0 \\ F_{FE} &= 40.031 \text{ kN (T)}\end{aligned}$$

| S. no. | Member | Magnitude (kN) | Nature of force |
|--------|--------|----------------|-----------------|
| 1 | AB | 23.112 | Compression |
| 2 | AG | 20.016 | Tension |
| 3 | BC | 23.112 | Compression |
| 4 | BG | 0 | — |
| 5 | CD | 28.903 | Compression |
| 6 | CF | 20.031 | Tension |
| 7 | CG | 0 | — |
| 8 | DE | 28.903 | Compression |
| 9 | DF | 20 | Compression |
| 10 | EF | 40.031 | Tension |
| 11 | FG | 20.016 | Tension |

6. Determine the forces in the members of truss as shown in Figure 7.7(a) by the method of joints.

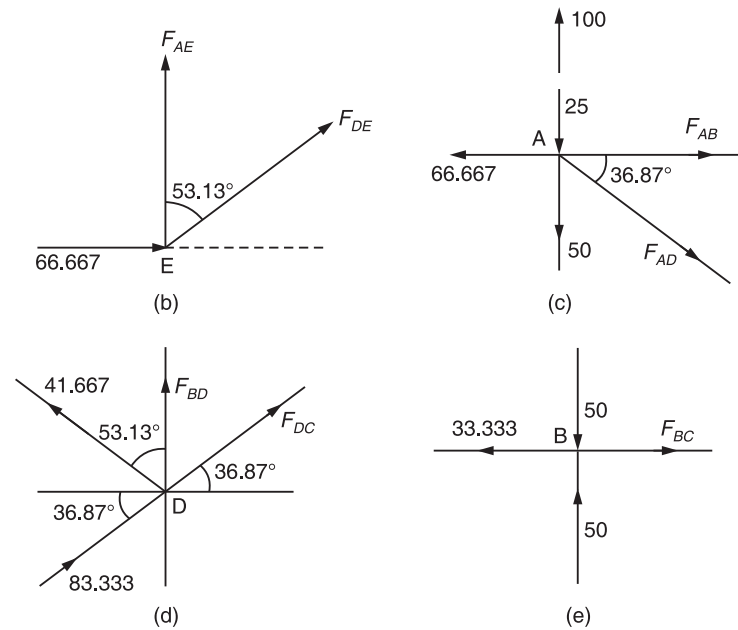

Figure 7.7

$$\begin{aligned}
 n &= n_e + n_i \\
 &= (R - r) + [m - (2j - 3)] \\
 &= 0 + [7 - (2(5) - 3)] \\
 &= 0
 \end{aligned}$$

Truss is statically determinate

$$\begin{aligned}
 \Sigma F_y &= 0 \\
 R_{AY} &= 25 + 50 + 25 = 100 \text{ kN}
 \end{aligned}$$

148 ELEMENTS OF CIVIL ENGINEERING AND ENGINEERING MECHANICS

$$\begin{aligned} & \Rightarrow \Sigma F_x = 0 \\ & R_E = R_{Ax} \\ & \Rightarrow \Sigma M_A = 0 \\ & -R_E \times 6 + 50 \times 4 + 25 \times 8 = 0 \\ & R_E = 66.667 \text{ kN} \\ & R_{Ax} = 66.667 \text{ kN} \end{aligned}$$

Consider joint E

$$\begin{aligned} & \Sigma F_x = 0 \\ & F_{DE} \sin[\tan^{-1}(8/6)] + 66.667 = 0 \\ & F_{DE} = -83.333 \text{ kN (C)} \\ & \Sigma F_y = 0 \\ & F_{AE} + F_{DE} \cos 53.13^\circ = 0 \\ & F_{AE} = 50 \text{ kN (T)} \\ & \frac{AC}{AE} = \frac{AB}{BD} \\ & \frac{8}{6} = \frac{4}{BD} \\ & \Rightarrow BD = 3 \text{ m} \end{aligned}$$

Consider joint A

$$\begin{aligned} & \Sigma F_y = 0 \\ & 100 - 25 - 50 - F_{AD} \sin 36.87^\circ = 0 \\ & F_{AD} = 41.667 \text{ kN (T)} \\ & \Sigma F_x = 0 \\ & F_{AB} = 66.667 + F_{AD} \cos 36.87^\circ = 0 \\ & F_{AB} = 33.333 \text{ kN (T)} \end{aligned}$$

Consider joint D

$$\begin{aligned} & \Sigma F_x = 0 \\ & F_{DC} \cos[\tan^{-1}(6/8)] - 41.667 \sin 53.13^\circ + 83.333 \cos 36.87^\circ = 0 \\ & F_{DC} = -41.667 \text{ kN (C)} \\ & \Sigma F_y = 0 \\ & F_{BD} + F_{CD} \sin 36.87^\circ + 41.667 \cos 53.13^\circ + 83.333 \sin 36.87^\circ = 0 \\ & F_{BD} = -50 \text{ kN (C)} \end{aligned}$$

Consider joint B

$$\begin{aligned}\Sigma F_x &= 0 \\ F_{BC} - 33.333 &= 0 \\ F_{BC} &= 33.333 \text{ kN (T)}\end{aligned}$$

| S. no. | Member | Magnitude of force (kN) | Nature of force |
|--------|--------|-------------------------|-----------------|
| 1. | AB | 33.333 | Tension |
| 2. | AD | 41.667 | Tension |
| 3. | AE | 50 | Tension |
| 4. | BC | 33.333 | Tension |
| 5. | BD | 50 | Compression |
| 6. | CD | 41.667 | Compression |
| 7. | DE | 83.333 | Compression |

7. Analyse the truss shown in Figure 7.8(a) by the method of joints and tabulate the result.

$$\begin{aligned}n &= n_e + n_i \\ &= (R - r) + [m - (2j - 3)] \\ &= 0 + [13 - (2 \times 8) - 3] \\ &= 0\end{aligned}$$

$$\Sigma F_x = 0$$

$$R_{Ax} = 0$$

$$\Sigma F_y = 0$$

$$R_{Ay} + R_E = 120$$

$$\Sigma M_A = 0$$

$$30 \times 4.8 + 60 \times 2 \times 4.8 + 30 \times 3 \times 4.8 - R_E \times 4 \times 4.8 = 0$$

$$R_E = 60 \text{ kN}$$

$$\therefore R_{Ay} = 60 \text{ kN}$$

$$\theta_1 = 36.87$$

$$\theta_2 = 14.04$$

$$\theta_3 = 53.13$$

Consider joint A

$$60 - F_{AF} \sin 36.87^\circ = 0$$

$$F_{AF} = 100 \text{ kN (T)}$$

$$\Sigma F_x = 0$$

$$F_{AB} + F_{AF} \cos 36.87^\circ = 0$$

$$F_{AB} = -80 \text{ kN (C)}$$

150 ELEMENTS OF CIVIL ENGINEERING AND ENGINEERING MECHANICS

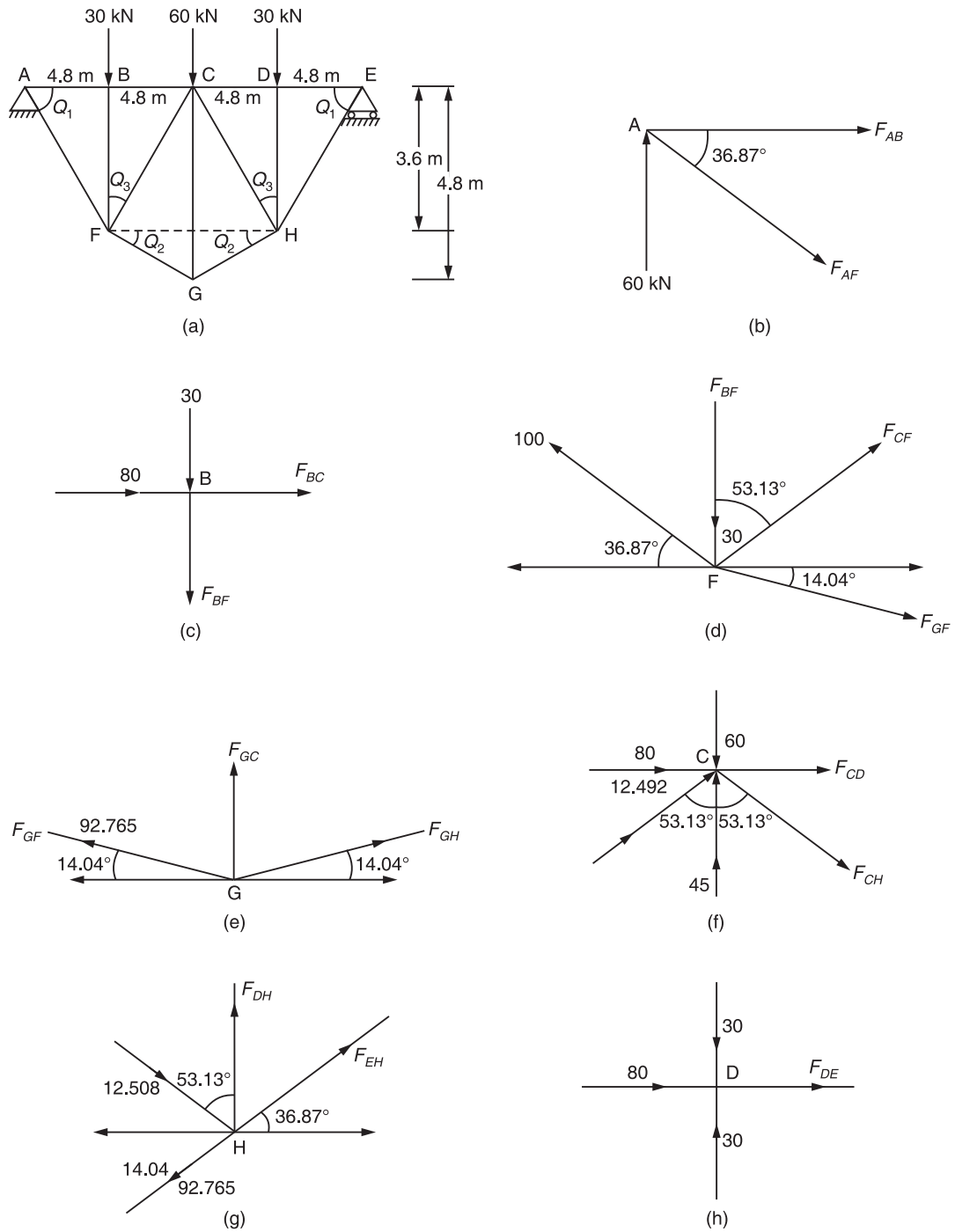

Figure 7.8

Consider joint B

$$\begin{aligned}\Sigma F_x &= 0 \\ F_{BC} + 80 &= 0 \\ F_{BC} &= -80 \text{ kN} \\ \Sigma F_y &= 0 \\ -F_{BF} - 30 &= 0 \\ F_{BF} &= -30 \text{ kN (C)}\end{aligned}$$

Consider Joint F

$$\begin{aligned}\Sigma F_x &= 0 \\ F_{CF} \sin 53.13^\circ + F_{GF} \cos 14.04^\circ - 100 \cos 36.87^\circ &= 0 \\ \Sigma F_y &= 0 \\ F_{CF} \cos 53.13^\circ - F_{GF} \sin 14.04^\circ + 100 \sin 36.87^\circ - 30 &= 0 \\ \therefore & \\ F_{CF} &= -12.492 \text{ kN (C)} \\ F_{GF} &= 92.765 \text{ kN (T)}\end{aligned}$$

Consider joint G

$$\begin{aligned}\Sigma F_x &= 0 \\ F_{GH} \cos 14.04^\circ - F_{GF} \cos 14.04^\circ &= 0 \\ F_{GH} &= F_{GF} = 92.765 \text{ kN (T)} \\ \Sigma F_y &= 0 \\ F_{GF} \sin 14.04^\circ + F_{GH} \sin 14.04^\circ + F_{GC} &= 0 \\ F_{GC} &= -45 \text{ kN (C)}\end{aligned}$$

Consider Joint C

$$\begin{aligned}\Sigma F_y &= 0 \\ 45 - 60 + 12.492 \cos 53.13^\circ - F_{CH} \cos 3.13^\circ &= 0 \\ F_{CH} &= -12.508 \text{ kN (C)} \\ \Sigma F_x &= 0 \\ 80 + F_{CD} + F_{CH} \sin 53.13^\circ + 12.492 \sin 53.13^\circ &= 0 \\ F_{CD} &= -80 \text{ kN (C)}\end{aligned}$$

Consider Joint H

$$\begin{aligned}F_{EH} \cos 36.87^\circ - 92.765 \cos 14.04^\circ + 12.508 \sin 53.13^\circ &= 0 \\ F_{EH} &= 100 \text{ kN (T)} \\ \Sigma F_y &= 0 \\ F_{DH} + F_{EH} \sin 36.87^\circ - 92.765 \sin 14.04^\circ - 12.508 \cos 53.13^\circ &= 0 \\ F_{DH} &= -30 \text{ kN (C)}\end{aligned}$$

Consider Joint D

$$F_{DH} = -80 \text{ kN (C)}$$

152 ELEMENTS OF CIVIL ENGINEERING AND ENGINEERING MECHANICS

| S. no. | Member | Magnitude (kN) | Nature of force |
|--------|--------|----------------|-----------------|
| 1 | AB | 80 | Compression |
| 2 | AF | 100 | Tension |
| 3 | BC | 80 | Compression |
| 4 | BF | 30 | Compression |
| 5 | CD | 80 | Compression |
| 6 | CF | 12.492 | Compression |
| 7 | CG | 45 | Compression |
| 8 | CH | 12.508 | Compression |
| 9 | DE | 80 | Compression |
| 10 | DH | 30 | Compression |
| 11 | EH | 100 | Tension |
| 12 | HG | 92.765 | Tension |
| 13 | GF | 92.765 | Tension |

8. Analyse the truss shown in Figure 7.9(a) by the method of joints, and tabulate the result.

$$\begin{aligned}
 n &= n_e + n_i \\
 &= (R - r) + [m - (2j - 3)] \\
 &= 3 - 3 + [9 - 2(6) - 3] \\
 &= 0 + (9 - 9) \\
 &= 0
 \end{aligned}$$

$$\Sigma F_x = 0$$

$$R_{CX} = 20 \cos 53.13^\circ$$

$$R_{CX} = 12 \text{ kN}$$

$$\Sigma F_y = 0$$

$$R_A + R_{CY} = 120 - 20 \sin 53.13^\circ$$

$$\Sigma M_A = 0$$

$$60 \times 4 + 60 \times 8 - R_{CY} \times 8 - 20 \sin 53.13^\circ \times 12 = 0$$

$$R_{CY} = 66 \text{ kN}$$

\therefore

$$R_A = 38 \text{ kN}$$

Consider joint A

$$\Sigma F_y = 0$$

$$F_{AE} \sin 36.87^\circ + 38 = 0$$

$$F_{AE} = -63.333 \text{ kN (C)}$$

$$\Sigma F_x = 0$$

$$F_{AB} + F_{AE} \cos 36.87^\circ = 0$$

$$F_{AB} = 50.667 \text{ kN (T)}$$

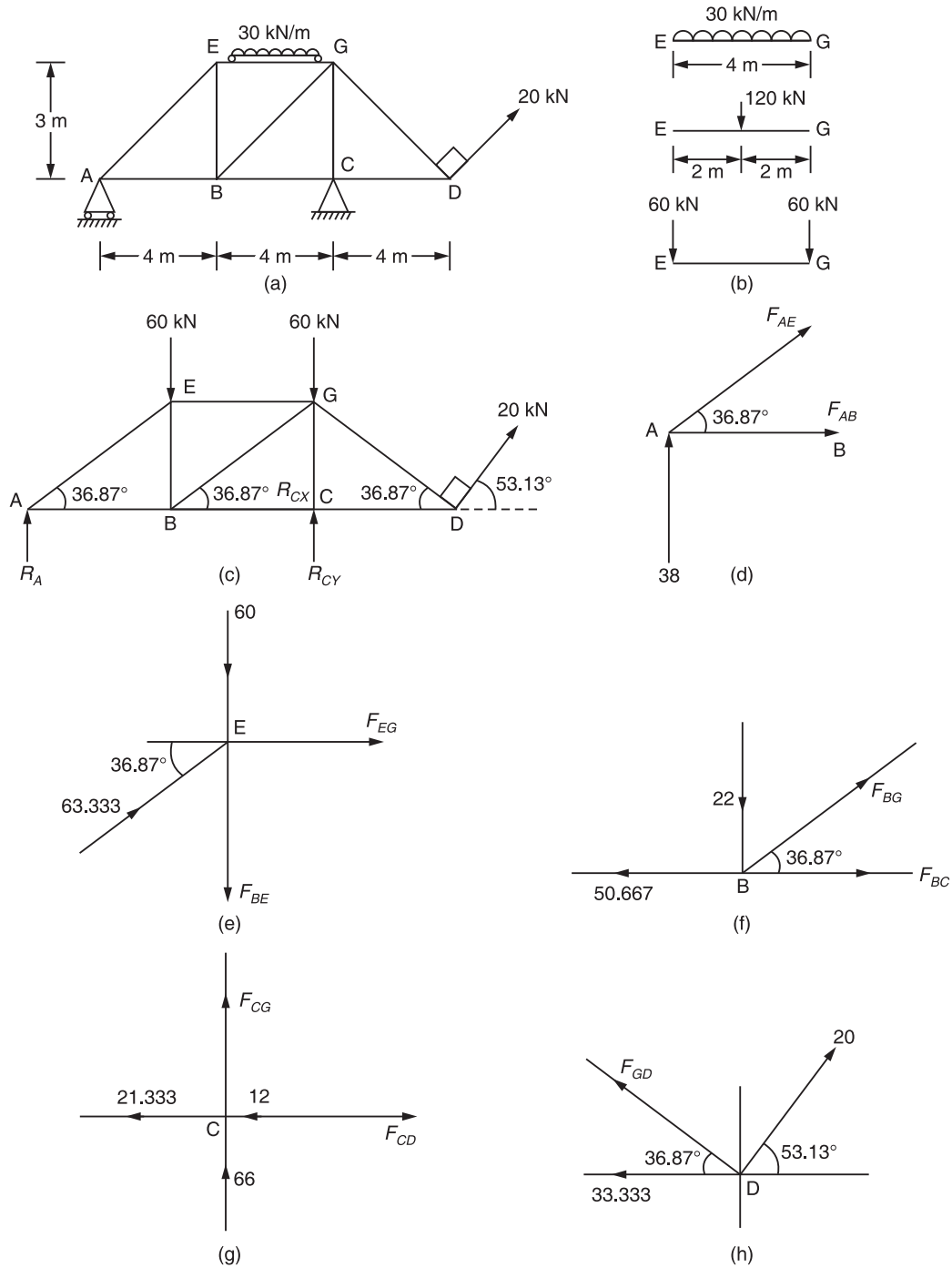

Figure 7.9

154 ELEMENTS OF CIVIL ENGINEERING AND ENGINEERING MECHANICS

Consider joint E

$$\Sigma F_x = 0$$

$$F_{EG} = -63.333 \cos 36.87^\circ \\ = -50.667 \text{ kN (C)}$$

$$\Sigma F_y = 0$$

$$-F_{BE} = -60 + 63.333 \sin 36.87^\circ \\ F_{BE} = -22 \text{ kN (C)}$$

Consider joint B

$$\Sigma F_y = 0$$

$$F_{BG} \sin 36.87^\circ - 22 = 0$$

$$F_{BG} = 36.667 \text{ kN (T)}$$

$$\Sigma F_x = 0$$

$$F_{BC} + F_{BG} \cos 36.87^\circ - 50.667 = 0$$

$$F_{BC} = 21.333 \text{ kN (T)}$$

Consider joint C

$$\Sigma F_x = 0$$

$$F_{CD} = 21.333 + 12 \\ = 33.333 \text{ kN (T)}$$

$$\Sigma F_y = 0$$

$$F_{CG} = -66 \text{ kN (C)}$$

Consider joint D

$$\Sigma F_x = 0$$

$$-F_{GD} \cos 36.87^\circ + 20 \cos 53.13^\circ$$

$$F_{BE} = -33.333 = 0$$

$$F_{GD} = -26.667 \text{ kN (C)}$$

| S. no. | Member | Magnitude of force (kN) | Nature of force |
|--------|--------|-------------------------|-----------------|
| 1 | AB | 50.667 | Tension |
| 2 | AE | 63.333 | Compression |
| 3 | BC | 21.333 | Tension |
| 4 | BE | 22 | Compression |
| 5 | BG | 36.667 | Tension |
| 6 | CD | 33.333 | Tension |
| 7 | CG | 66 | Compression |
| 8 | DG | 26.667 | Compression |
| 9 | EG | 50.667 | Compression |

9. Analyse the truss shown in Figure 7.10(a) by the method of joints, and tabulate the result.

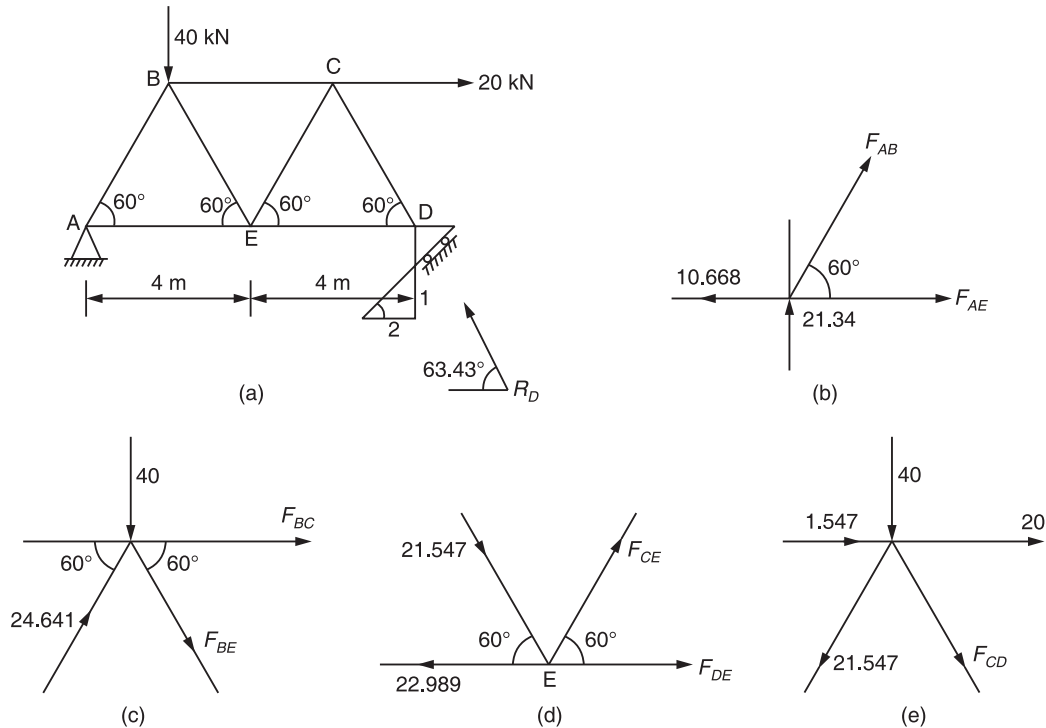

Figure 7.10

$$\begin{aligned}
 n &= n_e + n_i \\
 &= (R - r) + [m - (2j - 3)] \\
 &= (3 - 3) + [7 - (2(5) - 3)] \\
 &= 0 + (7 - 7) \\
 &= 0
 \end{aligned}$$

Truss is statically determinate

$$\theta = 26.57^\circ$$

$$\Sigma F_x = 0$$

$$R_{AX} - R_D \cos 63.43^\circ + 20 = 0$$

$$R_{AX} - R_D \cos 63.43^\circ = -20$$

$$\Sigma F_y = 0$$

$$R_{AY} + R_D \sin 63.43^\circ - 40 = 0$$

$$R_{AX} - R_D \sin 63.43^\circ = 40$$

$$\Sigma M_A = 0$$

$$40 \times 2 + 20 \times 2 \tan 60^\circ - R_D \cos 26.57^\circ \times 8 = 0$$

156 ELEMENTS OF CIVIL ENGINEERING AND ENGINEERING MECHANICS

$$R_D = \frac{16.909 \text{ kN}}{8} = 20.863 \text{ kN}$$

$$R_{AX} = -10.668 \text{ kN}$$

$$R_{AY} = 21.34 \text{ kN}$$

Consider joint A

$$\Sigma F_y = 0$$

$$F_{AB} \sin 60^\circ + 21.34 = 0$$

$$F_{AB} = -24.641 \text{ kN (C)}$$

$$\Sigma F_x = 0$$

$$F_{AE} + F_{AB} \cos 60^\circ - 10.668 = 0$$

$$F_{AE} = 22.989 \text{ kN (T)}$$

Consider joint B

$$\Sigma F_y = 0$$

$$-F_{BE} \sin 60^\circ + 24.641 \sin 60^\circ - 40 = 0$$

$$F_{BE} = -21.547 \text{ kN (C)}$$

$$\Sigma F_x = 0$$

$$24.641 \cos 60^\circ + F_{BE} \cos 60^\circ + F_{BC} = 0$$

$$F_{BC} = -1.547 \text{ kN (C)}$$

Consider joint E

$$\Sigma F_y = 0$$

$$F_{CE} \sin 60^\circ - 21.547 \sin 60^\circ = 0$$

$$F_{CE} = 21.547 \text{ kN (T)}$$

$$\Sigma F_x = 0$$

$$F_{DE} + F_{CE} \cos 60^\circ + 21.547 \cos 60^\circ - 22.989 = 0$$

$$F_{DE} = 1.442 \text{ kN (T)}$$

Consider joint C

$$\Sigma F_y = 0$$

$$-F_{CD} \sin 60^\circ - 21.547 \sin 60^\circ = 0$$

$$F_{CD} = -21.547 \text{ kN (C)}$$

| S. no. | Member | Magnitude of force (kN) | Nature of force |
|--------|--------|-------------------------|-----------------|
| 1 | AB | 24.641 | Compression |
| 2 | AE | 22.989 | Tension |
| 3 | BC | 1.547 | Compression |
| 4 | BE | 21.547 | Compression |
| 5 | CD | 21.547 | Compression |
| 6 | CE | 21.547 | Tension |
| 7 | DE | 1.442 | Tension |

Method of section

Method of section is the method in which a section line has to be passed through the members in which the internal forces need to be calculated [see Figure 7.11(a) and (b)]. This method is suitable when it is necessary to find the forces induced in a few or selected members of a truss.

Some of the points to be remembered in using the method of section are as follows:

1. The section line should be a complete.

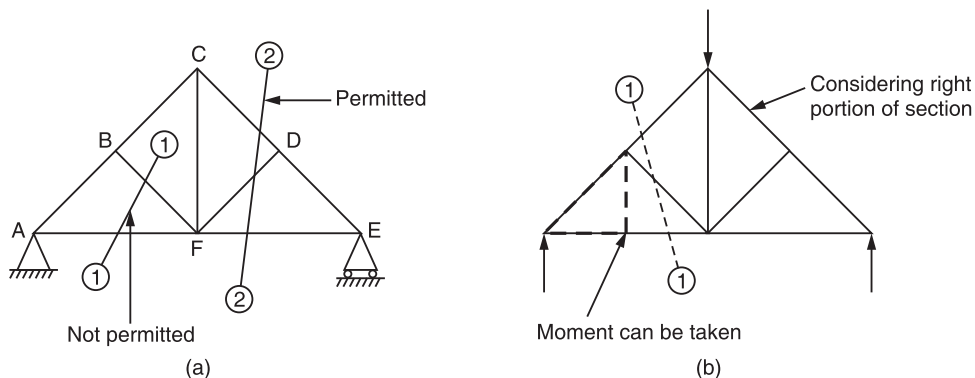

Figure 7.11

2. The section line should pass through the members, but not through the joints.
3. The section line can pass through maximum of three members because only three conditions of equilibrium are available.
4. The section line can pass through the four members in a situation where three members are meeting at a common point.
5. The moment equation of equilibrium can be applied about a point may be beyond the portion under consideration.
6. Consider either left portion or right portion whichever is easy for the analysis, as both portions are under equilibrium.

Now, let us go through the following discussions:

1. Determine the forces in the members BC, BG, EG & GD of the truss shown in Figure 7.12(a) by the method of sections.

$$\Sigma F_x = 0$$

$$R_{CX} = 20 \cos 53.13^\circ$$

$$R_{CX} = 12 \text{ kN}$$

$$\Sigma F_y = 0$$

$$R_A + R_{CY} + 20 \sin 53.13^\circ - 120 = 0$$

$$R_A + R_{CY} = 104$$

$$\Sigma M_C = 0$$

$$R_A \times 8 - 60 \times 4 - 20 \sin 53.13^\circ \times 4 = 0$$

$$R_A = 38 \text{ kN}$$

$$R_{CY} = 66 \text{ kN}$$

\therefore

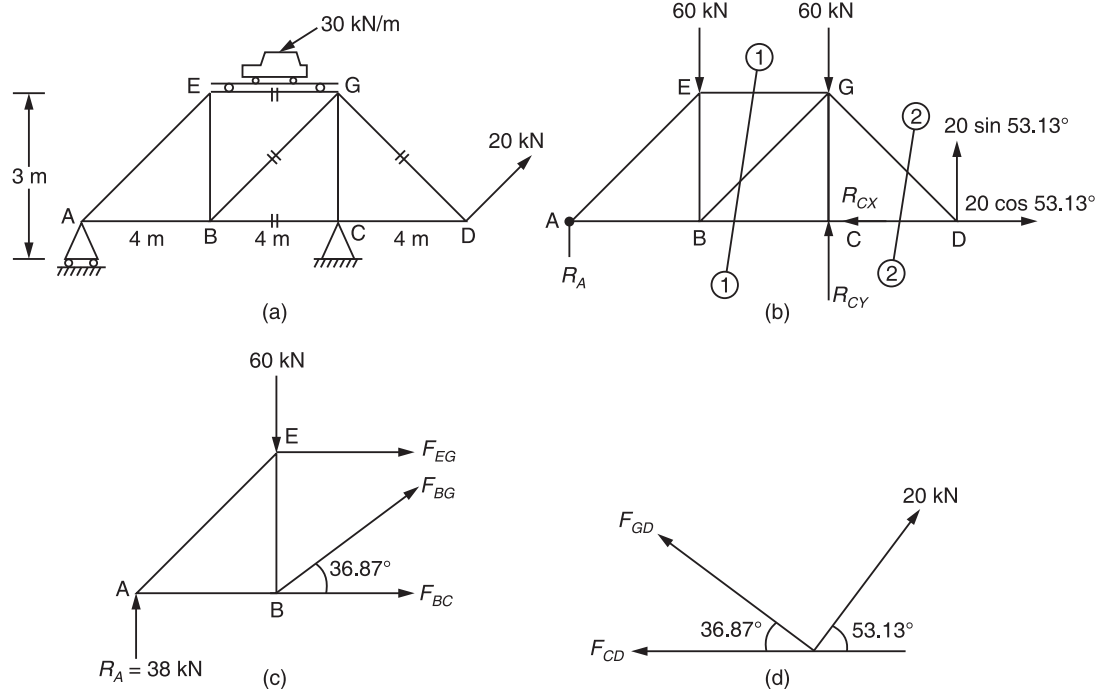

Figure 7.12

Choose a section line which passes through the members EG, BG & BC in which the internal forces need to be determined.

Consider the left portion of section line for the analysis.

The active members are EG, BG & BC.

The given force system forms a coplanar non-concurrent force system so that we can apply the three conditions of equilibrium.

$$\Sigma F_y = 0$$

$$F_{BG} \sin 36.87^\circ - 60 + 38 = 0$$

$$F_{BG} = 36.667 \text{ kN (T)}$$

$$\Sigma F_x = 0$$

$$F_{EG} + F_{BC} + F_{BG} \cos 36.57^\circ = 0$$

$$F_{EG} + F_{BC} = -29.333 \text{ kN (C)}$$

$$\Sigma M_B = 0$$

$$38 \times 4 + F_{EG} \times 3 = 0$$

$$F_{EG} = -50.667 \text{ kN (C)}$$

$$F_{BC} = 21.333 \text{ kN (T)}$$

\therefore

Calculation of force in GD

Choose a section line 2 & 2 and consider the right position of section line for the analysis.

$$\Sigma F_y = 0$$

$$F_{GD} \sin 36.87^\circ + 20 \sin 53.313^\circ = 0$$

\therefore

$$F_{GD} = -26.667 \text{ kN (C)}$$

2. Find the support reactions and forces in the members BC, CF, EF & CE of truss as shown in Figure 7.13(a).

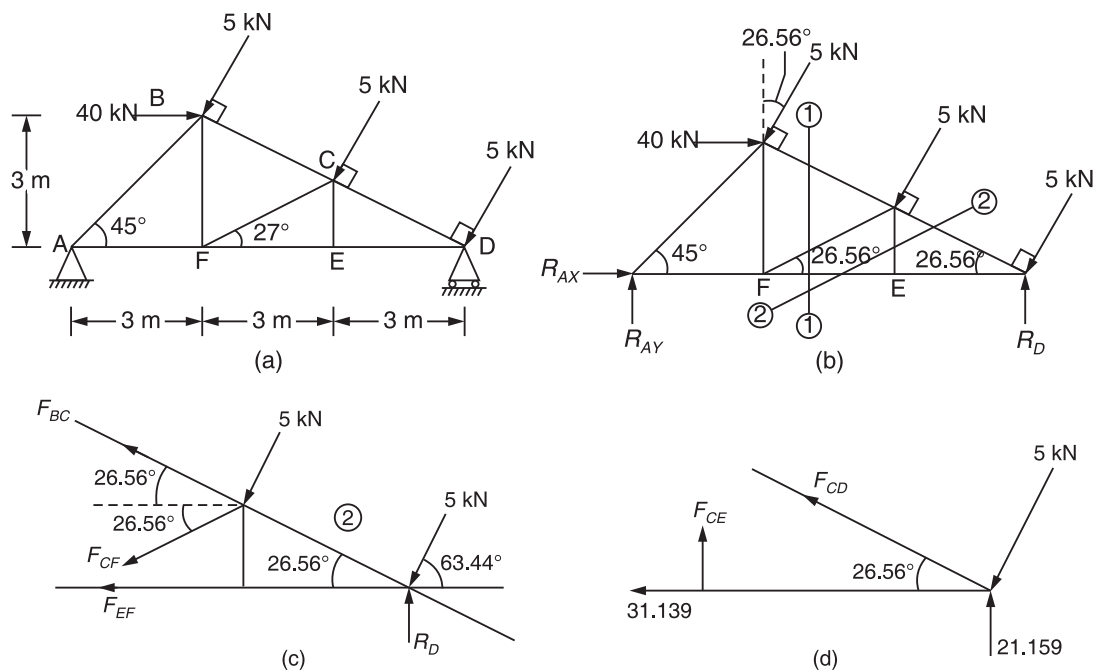

Figure 7.13

$$\Sigma F_x = 0$$

$$R_{AX} + 40 - 5 \sin 26.56^\circ - 5 \sin 26.56^\circ - 5 \sin 26.56^\circ = 0$$

$$R_{AX} = -33.293 \text{ kN}$$

$$\Sigma F_y = 0$$

$$R_{AY} + R_D - 3 \times 5 \cos 26.56^\circ = 0$$

$$R_{AY} + R_D = 13.417 \text{ kN}$$

$$\cos 26.56^\circ = \frac{ED}{CD}$$

$$CD = \frac{3}{\cos 26.56^\circ} = 3.354 \text{ m}$$

160 ELEMENTS OF CIVIL ENGINEERING AND ENGINEERING MECHANICS

$$BD = 6.708 \text{ m}$$

$$\Sigma M_D = 0$$

$$R_{AY} \times 9 - 5 \times 6.708 - 5 \times 3.35 + 40 \times 3 = 0$$

$$R_{AY} = -7.743 \text{ kN}$$

$$\therefore R_D = 21.159 \text{ kN}$$

$$F_{EF} + F_{CF} \cos 26.56^\circ + F_{BC} \cos 26.56^\circ + 5 \cos 63.44^\circ \times 2 = 0$$

$$\Sigma F_y = 0$$

$$F_{BC} \sin 26.56^\circ - F_{CF} \sin 26.56^\circ - 5 \sin 63.44^\circ \times 2 + 21.159 = 0$$

$$F_{EF} + F_{CF} \cos 26.56^\circ + F_{BC} \cos 26.56^\circ = -10 \cos 63.44^\circ$$

$$F_{CF} \sin 26.56^\circ - F_{BC} \sin 26.56^\circ = 12.214$$

$$\Sigma M_C = 0$$

$$F_{EF} \times 1.5 + 5 \times 3.354 - 21.159 \cos 26.56^\circ \times 3.354 = 0$$

$$F_{EF} = 31.15 \text{ kN (T)}$$

$$\therefore F_{CF} = -6.248 \text{ kN (C)}$$

$$F_{BC} = -33.564 \text{ kN (C)}$$

$$\Sigma F_x = 0$$

$$-F_{CD} \cos 26.56^\circ - 31.139 - 5 \cos 63.44^\circ = 0$$

$$F_{CD} = -37.312 \text{ kN (C)}$$

$$\Sigma F_y = 0$$

$$F_{CE} + F_{CD} \sin 26.56^\circ - 5 \sin 63.44^\circ + 21.159 = 0$$

$$F_{CE} = 0$$

3. Determine the magnitude and nature of forces in members BD, CD & ED of the truss shown in Figure 7.14(a).

$$\Sigma F_x = 0$$

$$R_{GX} = 30 \text{ kN}$$

$$\Sigma F_y = 0$$

$$R_{Gy} + R_A = 10$$

$$\Sigma M_G = 0$$

$$GD = 1.732 \text{ m}$$

$$30 \times (1.732 + 3) + 10 \times 2 - R_A \times 4 = 0$$

$$R_A = 40.49 \text{ kN}$$

$$\therefore R_{gy} = -30.49 \text{ kN}$$

$$\frac{ED}{AD} = \frac{BC}{AB}$$

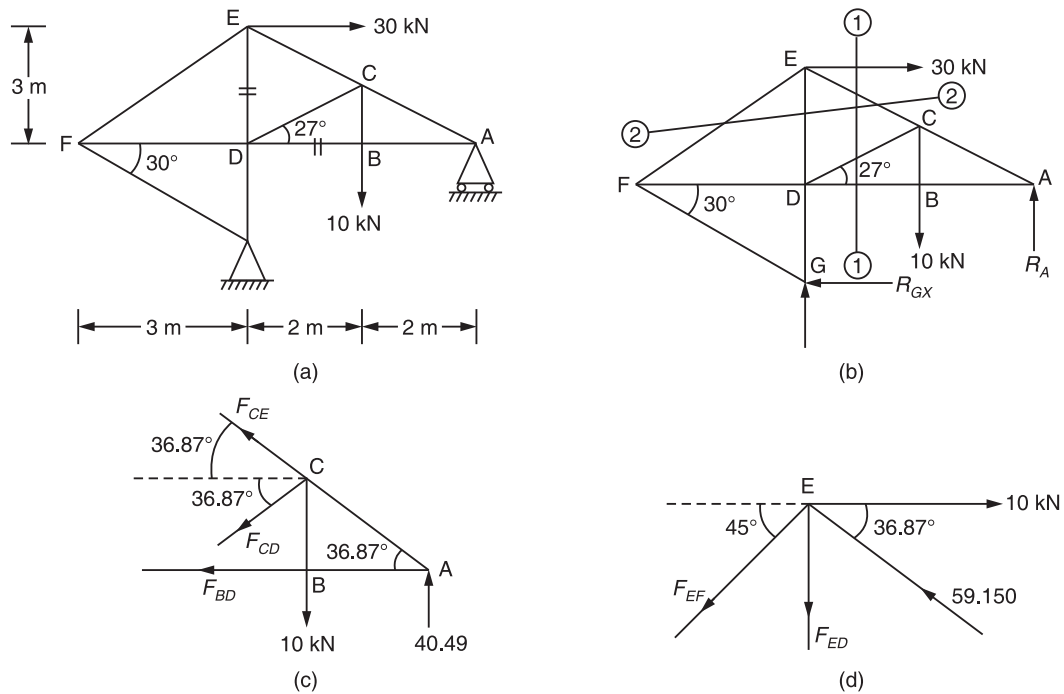

Figure 7.14

$$\frac{3}{4} = \frac{BC}{2}$$

$$BC = 1.5 \text{ m}$$

$$\sum M_C = 0$$

$$F_{BD} \times 1.5 - 40.42 \times 2 = 0$$

$$F_{BD} = 53.987 \text{ kN (T)}$$

$$\sum F_x = 0$$

$$-F_{CE} \cos 36.87^\circ - F_{CD} \cos 36.87^\circ - 53.987 = 0$$

$$F_{CE} \cos 36.87^\circ + F_{CD} \cos 36.87^\circ = -53.987$$

$$\sum F_y = 0$$

$$F_{CE} \sin 36.87^\circ - F_{CD} \sin 36.87^\circ = 10 - 40.49$$

$$F_{CE} = -59.150 \text{ kN (C)}$$

$$F_{CD} = -8.334 \text{ kN (C)}$$

$$\sum F_x = 0$$

$$-F_{EF} \cos 45^\circ - 59.15 \cos 36.87^\circ + 30 = 0$$

$$F_{EF} = -24.94 \text{ kN (C)}$$

$$\sum F_y = 0$$

$$-F_{ED} - F_{EF} \sin 45^\circ + 59.15 \sin 36.87^\circ = 0$$

$$F_{ED} = 52.810 \text{ kN (T)}$$

4. Determine the forces in the members of truss indicated below by the method of sections and tabulate the results. Members GC, BC, CD & EF.

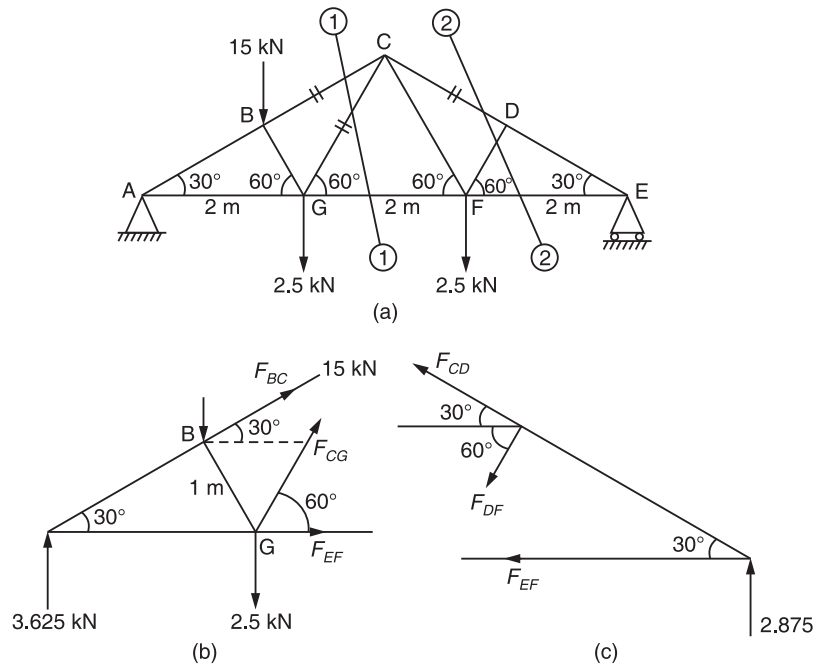

Figure 7.15

$$\Sigma F_x = 0$$

$$R_{AX} = 0$$

$$\Sigma F_y = 0$$

$$R_{Ay} + R_E = 1.5 + 2.5 + 2.5$$

$$R_{Ay} + R_E = 6.5$$

In ΔBAG ,

$$\cos 30^\circ = \frac{AB}{2}$$

$$AB = 1.732 \text{ m}$$

In $\Delta BAB'$,

$$\cos 30^\circ = \frac{AB'}{AB}$$

$$AB' = 1.5 \text{ m}$$

Similarly,

$$\sin 30^\circ = \frac{BB'}{AB}$$

$$BB' = 0.866 \text{ m}$$

$$\Sigma M_A = 0$$

$$1.5 \times 1.5 + 2.5 \times 2 + 2.5 \times 4 - R_E \times 6 = 0$$

$$R_E = 2.875 \text{ kN}$$

$$\therefore R_{Ay} = 3.625 \text{ kN}$$

$$\Sigma M_G = 0$$

$$3.625 \times 2 - 1.5 \times 0.5 + F_{BC} \times 1 = 0$$

$$F_{BC} = -6.5 \text{ kN (C)}$$

$$\Sigma F_y = 0$$

$$F_{BC} \sin 30 + F_{CG} \sin 60 + 3.625 - 1.5 - 2.5 = 0$$

$$F_{CG} = 4.186 \text{ kN}$$

Consider the right part of section line(2-2)

$$\Sigma M_D = 0$$

$$-2.875 \times 1.5 + F_{EF} \times 0.866 = 0$$

$$F_{EF} = 4.979 \text{ kN (T)}$$

$$\Sigma F_x = 0$$

$$-F_{CD} \cos 30^\circ - F_{DF} \cos 60^\circ - F_{EF} = 0$$

$$F_{CD} \cos 30^\circ + F_{DF} \cos 60^\circ = -4.979$$

$$\Sigma F_y = 0$$

$$F_{CD} \sin 30^\circ - F_{DF} \sin 60^\circ + 2.875 = 0$$

$$F_{CD} = -5.749 \text{ kN (C)}$$

$$F_{DF} = 0$$

5. Find the forces in the members AB, AD, EF & CD of truss as shown in Figure 7.16.

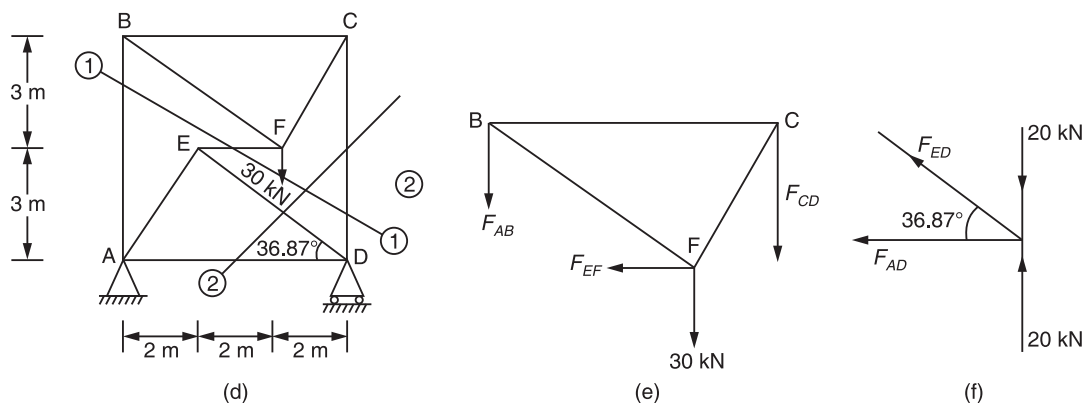

Figure 7.16

164 ELEMENTS OF CIVIL ENGINEERING AND ENGINEERING MECHANICS

$$\Sigma F_x = 0$$

$$R_{Ax} = 0$$

$$\Sigma F_y = 0$$

$$R_{Ay} + R_D = 30$$

$$30 \times 4 - R_D \times 6 = 0$$

$$R_D = 20 \text{ kN}$$

$$\therefore R_{Ay} = 10 \text{ kN}$$

Consider the upper part of section (1-1)

$$\Sigma F_x = 0$$

$$F_{EF} = 0$$

$$\Sigma F_y = 0$$

$$-F_{AB} - F_{CD} - 30 = 0$$

$$F_{AB} - F_{CD} - 30 = 0$$

$$\Sigma M_F = 0$$

$$-F_{AB} \times 4 + F_{CD} \times 2 = 0$$

$$\therefore F_{AB} = -10 \text{ kN (C)}$$

$$F_{CD} = -20 \text{ kN (C)}$$

Consider right portion of section (2-2)

$$\Sigma F_y = 0$$

$$F_{ED} \sin 36.87^\circ - 20 + 20 = 0$$

$$F_{ED} = 0$$

$$\Sigma F_x = 0$$

$$-F_{AD} - F_{ED} \cos 36.87^\circ = 0$$

$$F_{AD} = 0$$

EXERCISE PROBLEMS

- Determine the forces in the members by using method of joints only. Also mention the nature of forces in members as shown in Figure 7.17.

$$[\text{Ans.: } F_{AB} = 0, F_{AC} = 500 \text{ N (T)}, F_{AD} = 1442 \text{ N (C)}, F_{BD} = 200 \text{ N (T)}, \\ F_{CD} = 300 \text{ N (T)}, F_{CE} = 707.11 \text{ N (C)}, F_{ED} = 1000 \text{ N (C)}, \\ F_{DF} = 500 \text{ N (C)} \text{ and } F_{DF} = 707.11 \text{ N (T)}]$$

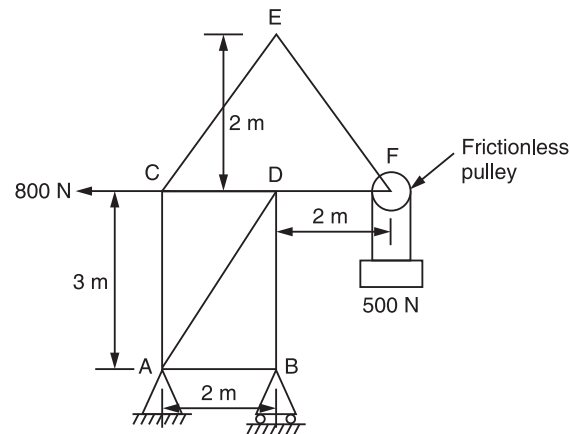

Figure 7.17

2. Determine the axial forces in the members of truss shown in Figure 7.18 using method of joints.

[Ans.: $F_{DF} = 335.35$ kN (T), $F_{BF} = 404.94$ kN (C), $F_{BD} = 395.35$ kN (T),
 $F_{AB} = 272.63$ (C), $F_{CE} = 248.85$ kN (T), $F_{CG} = 194.89$ kN (C), $F_{EG} = 0$]

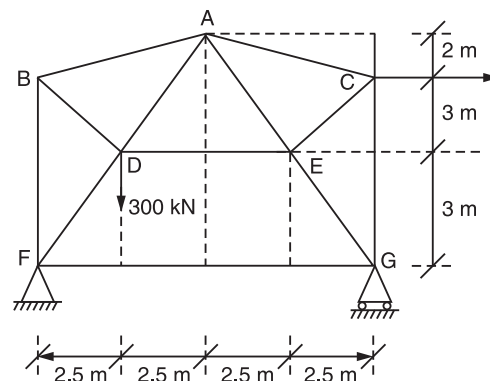

Figure 7.18

3. Determine the forces in all members of truss shown in Figure 7.19 using method of joints. Also verify forces in members DF, EF and EG.

[Ans.: $F_{AB} = 0$, $F_{AC} = 0$, $F_{BD} = 0$, $F_{BC} = 0$, $F_{DC} = 20$ kN (C), $F_{DF} = 20$ kN (C),
 $F_{DE} = 14.14$ kN (T), $F_{EC} = 0$, $F_{EF} = 10$ kN (T), $F_{EG} = 10$ kN (T),
 $F_{HF} = 10$ kN (C), $F_{HG} = 10$ kN (C), $F_{GF} = 14.14$ kN (C)]

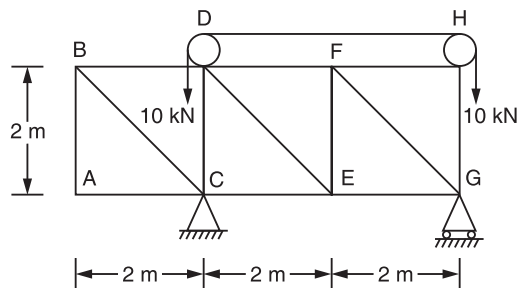

Figure 7.19

4. Find the magnitude and nature of members BC and ED by using suitable method of analysis of truss shown in Figure 7.20. [Ans.: $F_{BC} = 25 \text{ kN (C)}$ and $F_{ED} = 25 \text{ kN (T)}$]

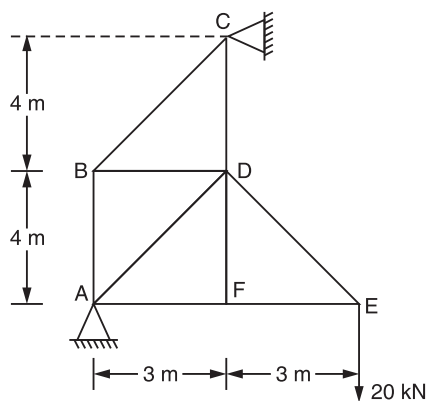

Figure 7.20

5. Determine the forces in all members of truss shown in Figure 7.21 using method of joints. [Ans.: $R_{Ax} = 26.185 \text{ kN}$, $R_{Ay} = 29.65 \text{ kN}$, $R_{Ex} = 26.185 \text{ kN}$, $R_{Ey} = 45.35 \text{ kN}$, $F_{AB} = F_{BC} = F_{AC} = F_{DF} = 0$, $F_{CD} = 75 \text{ kN (C)}$, $F_{DG} = 57.60 \text{ kN (C)}$, $F_{ED} = 84.14 \text{ kN (C)}$, $F_{AG} = 29.65 \text{ kN (T)}$, $F_{EF} = 49.40 \text{ kN (T)}$, $F_{AD} = 26.185 \text{ kN (C)}$ and $F_{GF} = 49.40 \text{ kN (T)}$]

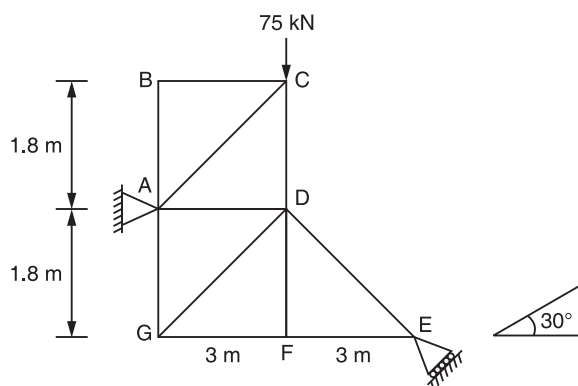

Figure 7.21

6. Determine the forces in all members of truss shown in Figure 7.22. Indicate the nature of forces also.

[Ans.: $F_{AC} = F_{CE} = F_{EG} = 198.18 \text{ kN (T)}$,
 $F_{BD} = F_{DF} = F_{GF} = 193.18 \text{ kN (C)}$ and $F_{AD} = F_{CF} = F_{CD} = F_{EF} = 0$]

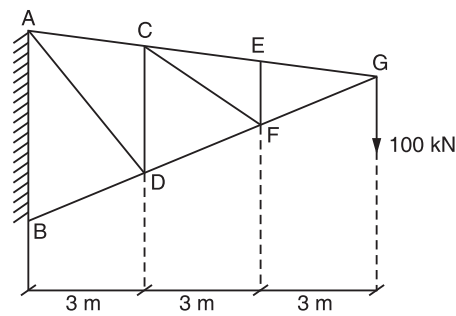

Figure 7.22

7. Determine the forces in all members of truss shown in Figure 7.23. State clearly nature of forces in each members.

[Ans.: $R_D = 15 \text{ kN}$, $R_{AY} = 20 \text{ kN}$, $R_{Ax} = 0$, $F_{AF} = 24.04 \text{ kN (T)}$, $F_{AB} = 13.34 \text{ kN (C)}$,
 $F_{BF} = 0$, $F_{BC} = 13.34 \text{ kN (C)}$, $F_{CF} = 6 \text{ kN (C)}$, $F_{EF} = 10 \text{ kN (T)}$, $F_{ED} = 10 \text{ kN (T)}$,
 $F_{CE} = 10 \text{ kN (T)}$ and $F_{CD} = 18.03 \text{ kN (C)}$]

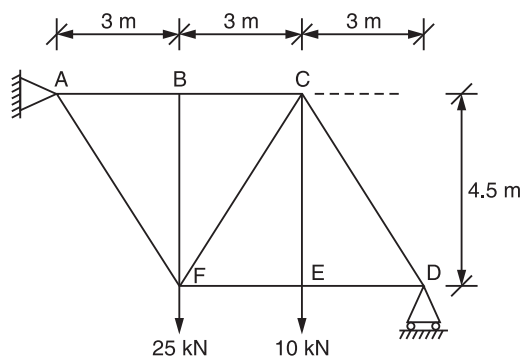

Figure 7.23

8. Determine the forces in magnitude and direction of a given truss shown in Figure 7.24 using the method of section.

[Ans.: $R_A = 8.66 \text{ kN}$, $R_{DX} = 10 \text{ kN}$, $R_{DY} = 13.23 \text{ kN}$, $F_{AB} = 10 \text{ kN (C)}$,
 $F_{AE} = 5 \text{ kN (T)}$, $F_{BE} = 10 \text{ kN (T)}$, $F_{BC} = 8.66 \text{ kN (C)}$,
 $F_{CD} = 8.66 \text{ kN (C)}$, $F_{EC} = 10 \text{ kN (C)}$, $F_{ED} = 15 \text{ kN (T)}$]

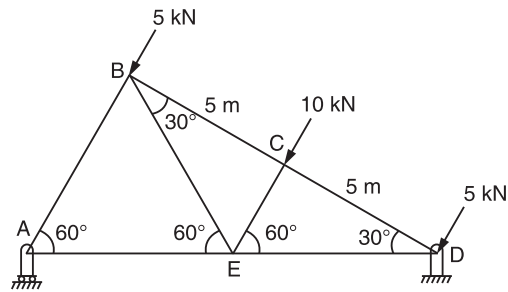

Figure 7.24

9. Determine the forces in the member BF, AB and EF of a given truss shown in Figure 7.25 using the method of section.

[Ans.: $F_{BF} = 25 \text{ kN (C)}$, $F_{AB} = 25 \text{ kN (C)}$, $F_{EF} = 20 \text{ kN (T)}$]

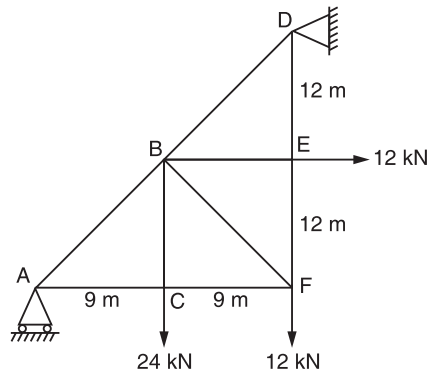

Figure 7.25

10. A truss of span 12 m is loaded as shown in Figure 7.26. Find the forces in members BD, CD and CE.

[Ans.: $F_{BD} = 6.67 \text{ kN (C)}$, $F_{CE} = 6.67 \text{ kN (T)}$, $F_{CD} = 1.67 \text{ kN (C)}$]

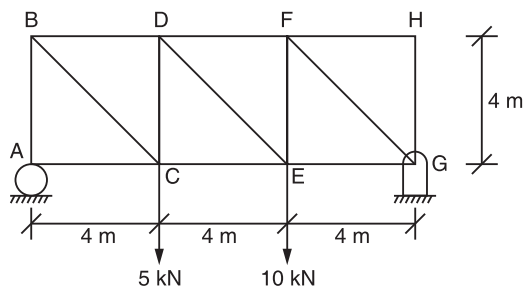

Figure 7.26

11. A truss is loaded and supported as shown in Figure 7.27. Find the axial forces in members 1, 2 and 3. [Ans.: $F_1 = 0.5 P$ (C), $F_2 = 0.5 P$ (T), $F_3 = 0.789 P$ (T)]

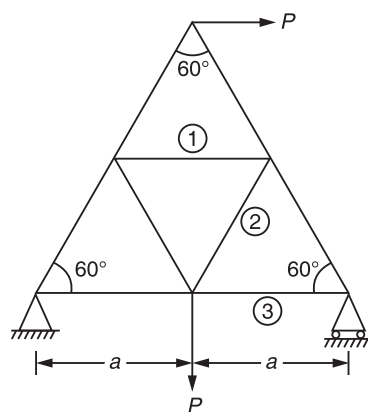

Figure 7.27

INTRODUCTION

Even when a smooth surface is observed under a microscope, it will be seen that the surface has undulations with troughs and crests as illustrated in Figure 8.1.

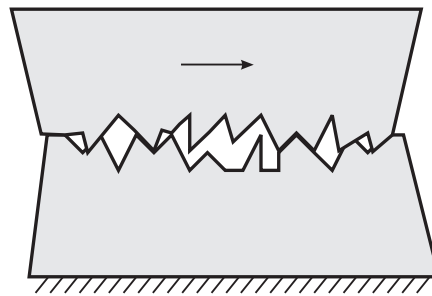

Figure 8.1 Two bodies moving over each other.

When two bodies with such undulations tend to move over each other as shown in Figure 8.1, the troughs and crests of one surface will have to overcome those of the other one, and hence in the initial stages a larger force is required to move the bodies relative to one over the other. This resistance offered to motion at the surfaces of the bodies is known as *frictional force*. When the bodies begin to move on each other with a certain velocity, the troughs and crests of the two

surfaces no longer mingle with each other and the bodies will be moving only over the crests of each other and hence the frictional force that is resisting the movement will be relatively less.

Hence, friction is the property by virtue of which a resistance is developed between the contact surfaces of two bodies when one body moves or tends to move over the other body. Friction can be observed in rough surfaces. The frictional force, F , is zero for smooth surfaces.

LIMITING FRICTION

The self-adjusting opposing and resisting friction F which opposes the sliding motion of one body over another, has a limiting value and if the applied force exceeds this value, the body begins to move. This limiting value of the force is called the limiting friction and at this stage the body is in limiting equilibrium and just on the verge of motion.

Coefficient of Friction (μ)

It is the constant ratio which the limiting friction F bears to the normal reaction N , i.e. as shown in Figure 8.2, where a body of weight W is in equilibrium under the applied force P and the frictional force F ,

$$\mu = \frac{F}{N}$$

$$\mu = 0, \text{ for smooth surfaces}$$

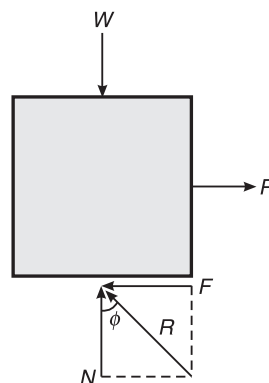
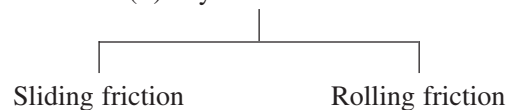

Figure 8.2 Coefficient of friction (μ).

TYPES OF FRICTION

Depending on the state of rest or motion, we can categorize friction into:

- (i) Static friction
- and
- (ii) Dynamic friction



172 ELEMENTS OF CIVIL ENGINEERING AND ENGINEERING MECHANICS

- (i) **Static friction:** It is the friction experienced between two bodies when both bodies are at rest.
- (ii) **Dynamic friction:** It is the friction experienced between two bodies when one body moves over the other body. It is of two types:
 - (a) *Sliding friction:* It is the resisting force which opposes the sliding motion of one body over another body, This force acts in a direction opposite to the direction of impending motion.
 - (b) *Rolling friction:* It is the friction between the two bodies when one body rolls over the other body.

Based on the surface of contact, there are two types of friction, namely:

- (i) **Dry friction:** If the contact surfaces between the two bodies are dry, then the friction between such bodies is known as dry friction.
- (ii) **Fluid friction:** The friction between two fluid layers or the friction between a solid and a fluid is known as fluid friction.

Angle of Friction (ϕ)

Let us again consider a body of weight W which is placed over a rough surface and is subjected to an external force P as shown in Figure 8.3. The following forces are acting on the body:

- (i) Self-weight, W
- (ii) External force, P
- (iii) Frictional force, F
- (iv) Normal reaction, N

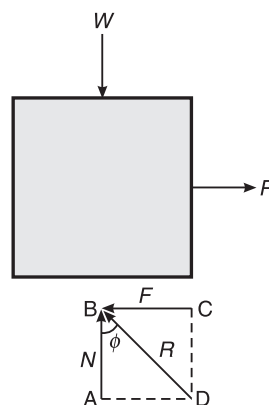

Figure 8.3 Angle of friction (ϕ).

The angle of friction for two contacting surfaces is the angle between the resultant R (of friction force F and the normal reaction N) and the normal reaction N . It is denoted by ϕ .

In triangle ABD,

$$\tan \phi = \frac{AD}{AB} = \frac{F}{N} = \mu \quad (8.1)$$

Angle of Repose (θ)

When a plane is inclined to the horizontal by a certain angle, the body placed on it will remain at rest up to a certain angle of inclination, beyond which the body just begins to move. This maximum angle made by the inclined plane with the horizontal, when the body placed on that plane is just at the point of sliding down the plane, is known as the angle of repose. Repose means sleep which is disturbed at that particular angle of inclination.

Let us consider a body of weight W which is placed on an inclined plane as shown in Figure 8.4. The body is just at the point of sliding down the plane when the angle of inclination is θ . The various forces acting on the body are self-weight, normal reaction, and frictional force.

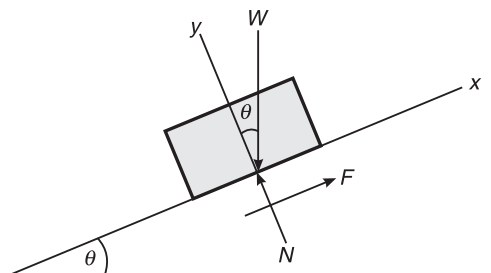

Figure 8.4 Angle of repose (θ).

Applying the conditions of equilibrium,

$$\Sigma F_x = 0; \Sigma F_y = 0$$

Resolving forces along the x -axis,

$$-F + W \sin \theta = 0$$

or

$$F = W \sin \theta \quad (8.2)$$

Resolving forces along the y -axis,

$$N - W \cos \theta = 0$$

or

$$N = W \cos \theta \quad (8.3)$$

We know that

$$\mu = \frac{F}{N}$$

\Rightarrow

$$\mu = \frac{W \sin \theta}{W \cos \theta} = \tan \theta \quad (8.4)$$

or

$$\tan \phi = \tan \theta$$

or

$$\phi = \theta$$

It is evident from Eqs. (8.1) and (8.4) that

Angle of friction = Angle of repose

Cone of Friction

The combination of resultant R of frictional force F and normal reaction N obtained by applying forces in opposite directions successively form a right circular cone of angle 2ϕ , known as the cone of friction, as shown in Figure 8.5.

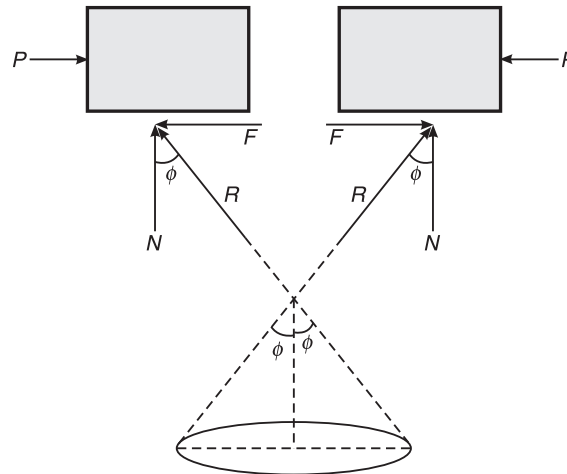

Figure 8.5 Cone of friction.

LAWS OF FRICTION

The laws of static friction are:

- (i) The force of friction always acts in a direction, opposite to that in which the body tends to move.
- (ii) The magnitude of the force of friction is exactly equal to the applied force which just moves the body.
- (iii) The magnitude of the limiting friction bears a constant ratio to the normal reaction between the two surfaces in contact, i.e.

$$\frac{F}{N} = \text{constant}$$

where F is the limiting friction and N is the normal reaction.

- (iv) The force of friction is independent of the area of contact between the two surfaces.
- (v) The force of friction depends upon the roughness of the surfaces in contact.

The laws of dynamic friction are:

- (i) The force of friction always acts in a direction, opposite to that in which the body is moving.
- (ii) The magnitude of the kinetic friction bears a constant ratio to the normal reaction between the two surfaces in contact. But this ratio is slightly less than that in the case of limiting friction.
- (iii) The friction force remains constant for moderate speeds but decreases slightly with the increase in speed.

Tips to Solve the Problems

- (i) Draw a free body diagram.
- (ii) Draw the reference axes. We have to choose the reference axes in such a way that one of the axis must be along the direction of motion.

The following forces should be considered while drawing the free body diagram.

- (i) Self-weight always acts **vertically downwards**.
- (ii) External or internal forces.
- (iii) In a rough surface (with a non-zero coefficient of friction), two forces must be present.
 - (a) Frictional force (tangential force) which is **always opposite to the direction of motion at the contact surface and is parallel to the contact surface**.
 - (b) Normal reaction, which is always **perpendicular to the contact surface**.
- (iv) Write the algebraic sum of the forces along the x -axis, i.e. $\Sigma F_x = 0$
- (v) Write the algebraic sum of the forces along the y -axis, i.e. $\Sigma F_y = 0$
- (vi) Write the limiting friction equation, i.e. $\mu = F/N$.
- (vii) Solve for the three unknowns from the three equations.

Example 8.1 A block shown in Figure 8.6 is just moved by a force of 200 N. The weight of the block is 600 N. Determine the coefficient of static friction between the block and the floor.

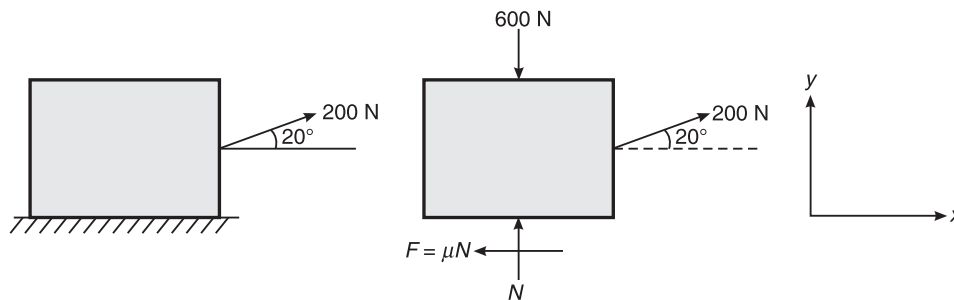

Figure 8.6 Example 8.1.

Solution Considering the conditions of equilibrium,

$$\Sigma F_x = 0$$

or $200 \cos 20^\circ - \mu N = 0$

or $\mu N = 187.938$ (i)

$$\Sigma F_y = 0$$

or $N - 600 + 200 \sin 20^\circ = 0$

or $N = 531.596 \text{ N}$ (ii)

Substituting the value of N in Eq. (i), we get

$$\mu = 0.35$$

Ans.

Example 8.2 A block of mass 20 kg placed on an inclined plane as shown in Figure 8.7, is subjected to a force P that is parallel to the plane. Taking the inclination of plane with respect to horizontal as 30° and the coefficient of friction as 0.24, determine the value of P for impending motion of the block.

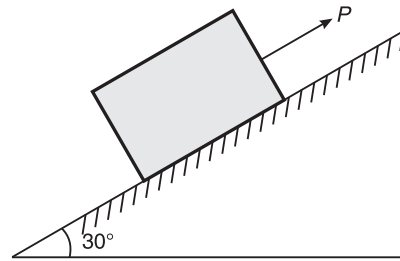

Figure 8.7 Example 8.2.

Solution (i) The value of P for impending motion down the plane (Figure 8.8):

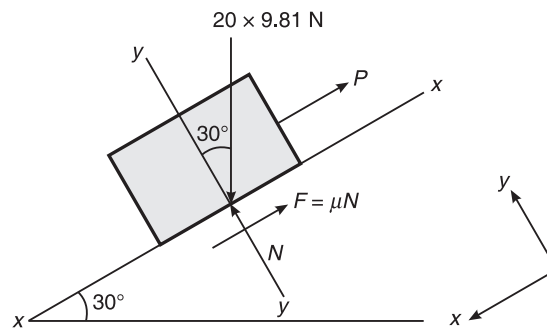

Figure 8.8 Example 8.2.

Consider the free body diagram of block

$$\Sigma F_y = 0$$

or $20 \times 9.81 \times \cos 30^\circ - N = 0$

or $N = 20 \times 9.81 \cos 30^\circ = 169.914 \text{ N}$

Also, $\Sigma F_x = 0$

or $-P - 0.24 \times 169.914 + 20 \times 9.81 \sin 30^\circ$

$\therefore P = 57.320 \text{ N}$

Ans.

(ii) The value of P for impending motion up the plane (Figure 8.9)

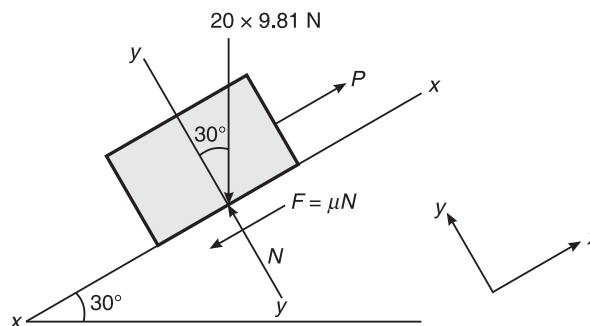

Figure 8.9 Example 8.2.

Consider the free body diagram of block

$$\Sigma F_y = 0$$

or $N = 20 \times 9.81 \cos 30^\circ$

or $N = 169.914 \text{ N}$

Also, $\Sigma F_x = 0$

or $-20 \times 9.81 \sin 30^\circ + P - \mu N = 0$

or $P = 20 \times 9.81 \sin 30^\circ + 0.24 \times 169.914$

$\therefore P = 138.879 \text{ N}$

Ans.

Example 8.3 A small block of weight 1000 N as shown in Figure 8.10, is placed on a 30° inclined plane with $\mu = 0.25$. Determine the horizontal force to be applied for:

- (i) Impending motion down the plane
- (ii) Impending motion up the plane.

VTU(August 99, March 2005)

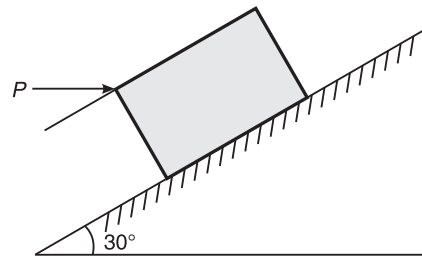

Figure 8.10 Example 8.3.

Solution (i) *Impending motion down the plane* (Figure 8.11):

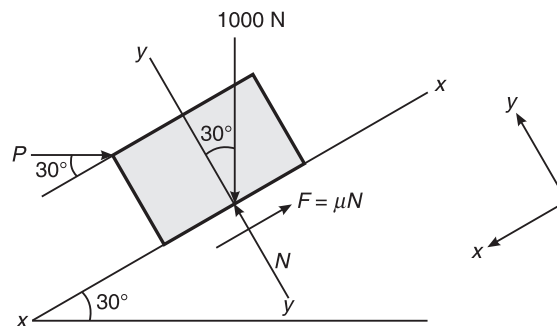

Figure 8.11 Example 8.3.

$$\Sigma F_y = 0$$

or $N = 1000 \cos 30^\circ - P \sin 30^\circ = 0$

or $N = 866.025 + 0.5P$

Also, $\Sigma F_x = 0$

178 ELEMENTS OF CIVIL ENGINEERING AND ENGINEERING MECHANICS

$$\text{or} \quad -0.25(1000 \cos 30^\circ + 0.5P) - P \cos 30^\circ + 1000 \sin 30^\circ = 0$$

$$\text{or} \quad -216.506 - 0.125P - 0.866P + 500 = 0$$

$$\text{or} \quad 0.991P = 283.494$$

$$\text{or} \quad P = 286.068 \text{ N}$$

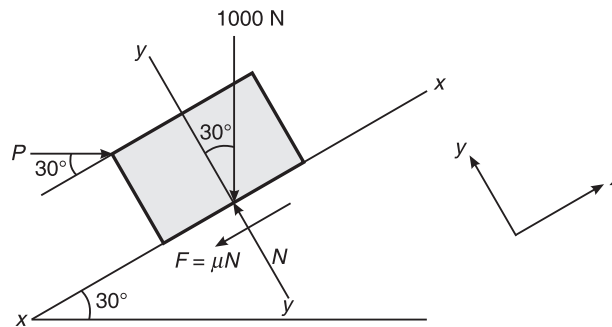
Ans.(ii) *Impending motion up the plane* (Figure 8.12):**Figure 8.12** Example 8.3.

$$\Sigma F_y = 0$$

$$\text{or} \quad N - P \sin 30^\circ - 1000 \cos 30^\circ = 0$$

$$\text{or} \quad N = P \sin 30^\circ + 1000 \cos 30^\circ$$

$$= P \sin 30^\circ + 866.025$$

$$\text{Also,} \quad \Sigma F_x = 0$$

$$\text{or} \quad -0.25(P \sin 30^\circ + 866.025) - 1000 \sin 30^\circ + P \cos 30^\circ$$

$$\text{or} \quad -216.506 - 0.125P + 0.866P - 500 = 0$$

$$\text{or} \quad 0.741P = 716.506$$

$$\therefore P = \frac{716.506}{0.741} = 966.944 \text{ N}$$

Ans.

Example 8.4 A block weighing 1500 N rests on a plane inclined at 20° to the horizontal (Figure 8.13). If $\mu = 0.3$, find the force required to push the block up the plane when the line of action of force makes an angle of 30° with the plane.

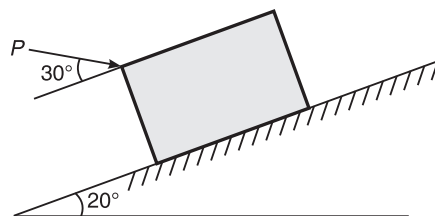
**Figure 8.13** Example 8.4.

Solution Consider the free body diagram (Figure 8.14),

$$\Sigma F_y = 0$$

or $-P \sin 30^\circ - 1500 \cos 20^\circ + N = 0$

or $N = P \sin 30^\circ + 1500 \cos 20^\circ$
 $= 0.5P + 1409.539$

Also, $\Sigma F_x = 0$

or $P \cos 30^\circ - 1500 \sin 20^\circ - 0.3(0.5P + 1409.539) = 0$

or $0.866P - 513.03 - 0.15P - 422.861 = 0$

or $0.716P = 935.891$

or $P = 1307.110 \text{ N}$

Ans.

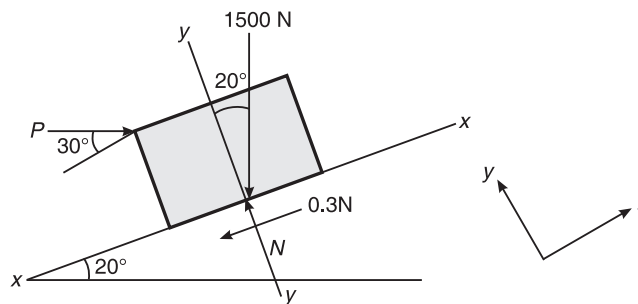

Figure 8.14 Example 8.4.

Example 8.5 A body of weight 200 kN is acted upon by a force of 40 kN as shown in Figure 8.15. If the coefficient of friction between the inclined plane and the body is 0.3, check whether the body moves up the plane or remains stationary.

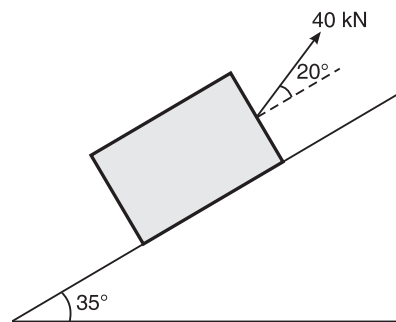

Figure 8.15 Example 8.5.

Solution Assuming that the motion is downwards, let P be the force required to prevent the motion.

Consider the free body diagram of the given weight (Figure 8.16),

$$\Sigma F_y = 0$$

or $N + 40 \sin 20^\circ - 200 \cos 35^\circ = 0$

180 ELEMENTS OF CIVIL ENGINEERING AND ENGINEERING MECHANICS

or $N = 150.15 \text{ kN}$
 $\therefore F = 0.3 \times 150.15 = 45.045 \text{ kN}$
 Also, $\Sigma F_x = 0$
 $-P - 0.3 \times 150.15 - 40 \cos 20^\circ + 200 \sin 35^\circ = 0$
 or $P = 32.083 \text{ kN}$ **Ans.**

The assumed value of P is correct, hence the weight is moving in the downward direction.

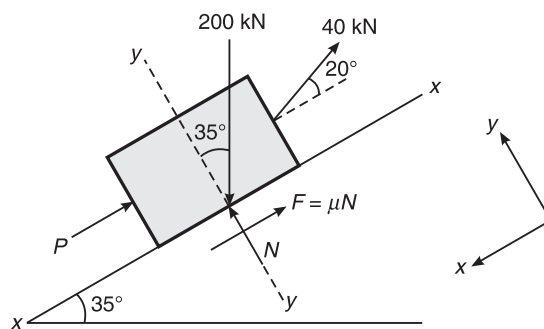

Figure 8.16 Example 8.5.

Example 8.6 A body resting in plane (horizontal) required a pull of 18 kN inclined at 30° to plane just to move it. It was also found that a push of 22 kN inclined at 30° to the plane just moved the body. Determine the weight of the body and the coefficient of friction.

Solution When a pull of 18 kN is applied (Figure 8.17).

$\Sigma F_y = 0$
 or $N - W + 18 \sin 30^\circ = 0$
 or $N = W - 9$ (i)

Also, $\Sigma F_x = 0$
 $-\mu(W - 9) + 18 \cos 30^\circ = 0$
 or $\mu = \frac{15.588}{W - 9}$ (ii)

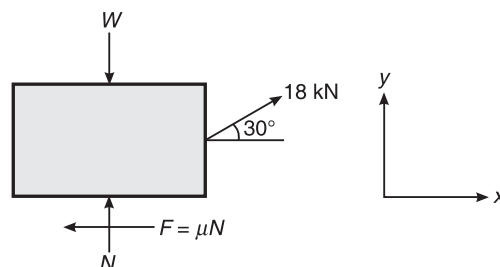

Figure 8.17 Example 8.6.

When a push of 22 kN is applied (Figure 8.18).

$$\Sigma F_y = 0$$

or
$$N - W - 22 \sin 30^\circ = 0$$

or
$$N = W + 11$$

Also,
$$\Sigma F_x = 0$$

or
$$-\mu(W + 11) + 22 \cos 30^\circ = 0$$

or
$$\mu = \frac{19.053}{W + 11} \quad \text{(iii)}$$

Equating Eqs. (ii) and (iii), we get

$$\frac{19.053}{W + 11} = \frac{15.588}{W - 9}$$

or
$$\frac{W - 9}{W + 11} = \frac{15.588}{19.053}$$

or
$$W - 9 = 0.818W + 8.9997$$

or
$$0.182W = 17.9997$$

or
$$W = 98.899 \text{ kN} \quad \text{Ans.}$$

$\therefore \mu = \frac{19.053}{W + 11} = \frac{19.053}{109.899} = 0.173 \quad \text{Ans.}$

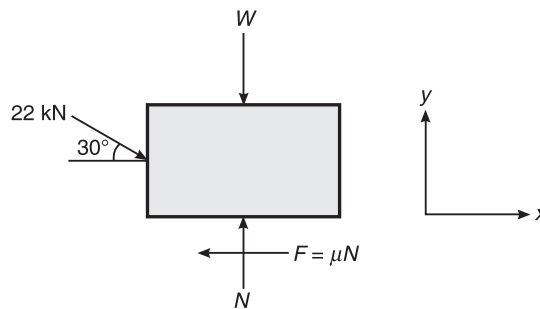

Figure 8.18 Example 8.6.

Example 8.7 The crate shown in Figure 8.19 has a mass of 580 kg. If $P = 6000 \text{ N}$, find the magnitude of the frictional force which acts on the crate. What value of P will cause the crate to have impending motion up the plane? Find the minimum value of P required to keep the crate from sliding down the plane. For what range of value of P will the crate remain in the equilibrium position shown in the figure? VTU(July 2006)

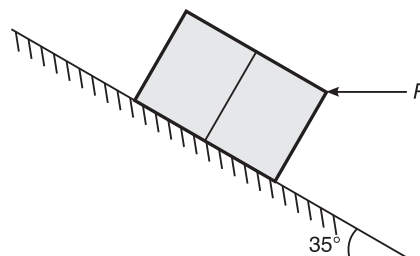

Figure 8.19 Example 8.7.

Solution Magnitude of the frictional force

$$\Sigma F_y = 0$$

or $N - 580 \times 9.81 \cos 35^\circ - 6000 \times \sin 35^\circ = 0$

or $N = 8102.269 \text{ N}$

\therefore Frictional force, $F = \mu N = 2025.567 \text{ N}$ (Take $\mu = 0.25$)

Ans.

The value of P for impending motion up the plane (frictional force acting down the plane) (Figure 8.20):

$$\Sigma F_y = 0$$

$\therefore N = 580 \times 9.81 \cos 35^\circ + P \sin 35^\circ$

Also, $\Sigma F_x = 0$

$$P \cos 35^\circ - 580 \times 9.81 \sin 35^\circ - 0.25(580 \times 9.81 \cos 35^\circ + P \sin 35^\circ) = 0$$

$\therefore P = 6550 \text{ N}$

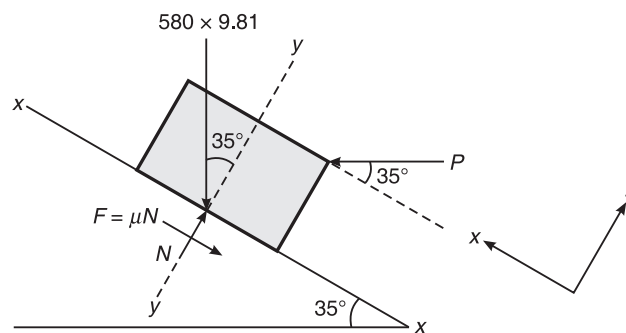

Figure 8.20 Example 8.7.

The value of P for impending motion down the plane (frictional force acting up the plane) (Figure 8.21):

$$\Sigma F_y = 0$$

or $N - 580 \times 9.81 \cos 35^\circ - P \sin 35^\circ = 0$

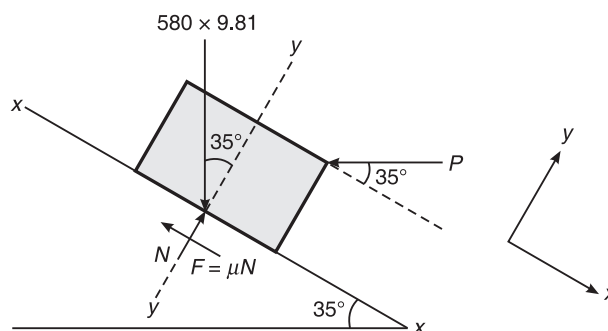

Figure 8.21 Example 8.7.

$$\therefore N = 580 \times 9.81 \cos 35^\circ + P \sin 35^\circ = 0$$

Also, $\Sigma F_x = 0$

or $-P \cos 35^\circ + 580 \times 9.81 \sin 35^\circ - 0.25(580 \times 9.81 \cos 35^\circ + P \sin 35^\circ) = 0$

$$\therefore P = 2181.218 \text{ N}$$

Ans.

\therefore Range of P is from 2181.218 N to 6550 N

Ans.

Example 8.8 A block weighing 4500 N resting on horizontal surface supports another block of 3000 N as shown in Figure 8.22. Find the horizontal force P required to just move the block to the left. Take the coefficient of friction for all contact surfaces as 0.3. VTU(August 2003)

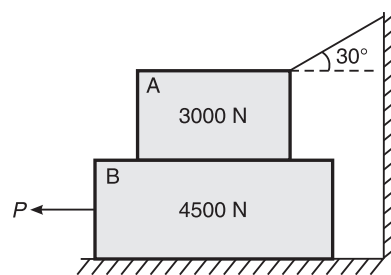

Figure 8.22 Example 8.8.

Solution When one body is placed over the other body, equal and opposite reactions and also equal and opposite frictional forces will come into existence between the contact surfaces of the two bodies as shown in Figure 8.23.

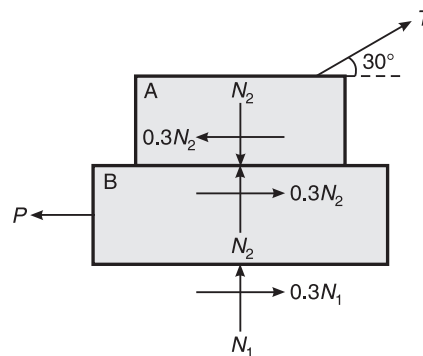

Figure 8.23 Example 8.8.

From Figure 8.24:

For $\Sigma F_y = 0$, we get

$$-3000 + N_2 + T \sin 30^\circ = 0$$

or

$$N_2 = 3000 - 0.5T$$

For $\Sigma F_x = 0$, we get

$$T \cos 30^\circ - 0.3(3000 - 0.5T) = 0$$

184 ELEMENTS OF CIVIL ENGINEERING AND ENGINEERING MECHANICS

$$\begin{aligned}
 \text{or} \quad & T \cos 30^\circ - 900 + 0.15T = 0 \\
 \text{or} \quad & 1.016T = 900 \\
 \text{or} \quad & T = 885.827 \text{ N} \\
 \text{or} \quad & N_2 = 3000 - 0.5T = 2557.086 \text{ N}
 \end{aligned}$$

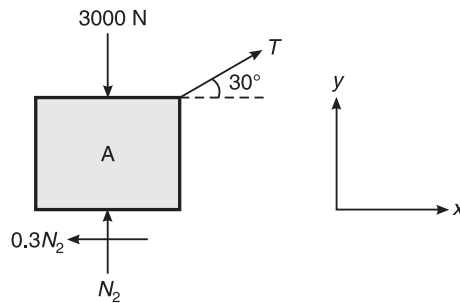

Figure 8.24 Example 8.8.

From Figure 8.25:
For $\Sigma F_y = 0$, we get

$$N_1 = 4500 + 2557.086 = 7057.086 \text{ N}$$

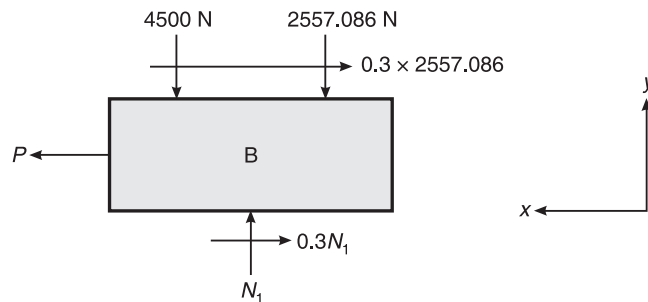

Figure 8.25 Example 8.8.

And for $\Sigma F_x = 0$,

$$P - 0.3 \times 7057.086 - 0.3 \times 2557.086 = 0$$

$$\text{or} \quad P = 2884.252 \text{ N}$$

Ans.

Example 8.9 A block weighing 6 kN is attached to a string, which passes over a frictionless pulley and supports a weight of 3 kN, when the coefficient of friction between the block and the floor is 0.35 (Figure 8.26). Determine the value of force P when the

- (i) motion is impending towards right.
- (ii) motion is impending towards left.

Whenever a body is hanging free in air, there is no need to consider normal reaction.

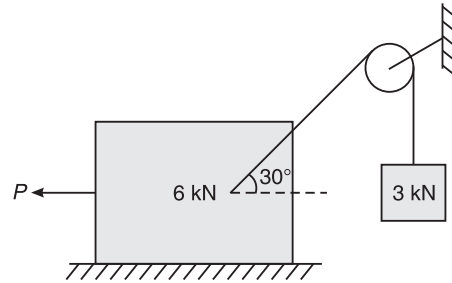

Figure 8.26 Example 8.9.

Solution Case 1: *When motion is impending towards right*
 Consider the free body diagram of 3 kN block (Figure 8.27):

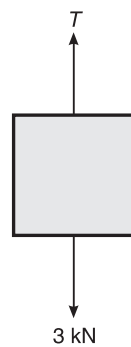

Figure 8.27 Example 8.9.

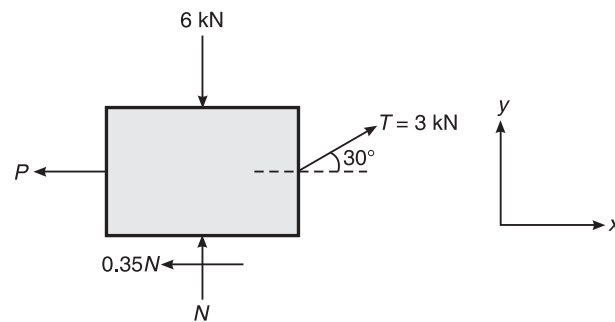

Figure 8.28 Example 8.9.

$$\Sigma F_y = 0$$

or $3 - T = 0$

or $T = 3 \text{ kN}$

Consider the free body diagram of 6 kN block (Figure 8.28):

$$\Sigma F_y = 0$$

or $3 \sin 30^\circ - 6 + N = 0$

or $N = 4.5 \text{ kN}$

Also, $\Sigma F_x = 0$

or $-P + 3 \cos 30^\circ - \mu N = 0$

or $P = 3 \cos 30^\circ - 0.35 \times 4.5 = 1.023 \text{ kN}$

Ans.

Case 2: *When motion is impending towards left* (Figure 8.29):

$$\Sigma F_y = 0$$

$$-3 \sin 30^\circ - 6 + N = 0$$

or $N = 7.5 \text{ kN}$

Also, $\Sigma F_x = 0$

or $P - 3 \cos 30^\circ - \mu N = 0$

or $P = 5.223 \text{ kN}$

Ans.

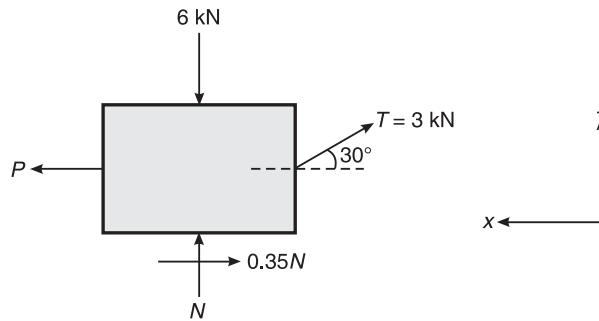

Figure 8.29 Example 8.9.

Example 8.10 Calculate the value of W required in Figure 8.30:

- (i) To cause the body to move in the upward direction.
- (ii) To cause the body to move in the downward direction.

Take $\mu = 0.3$.

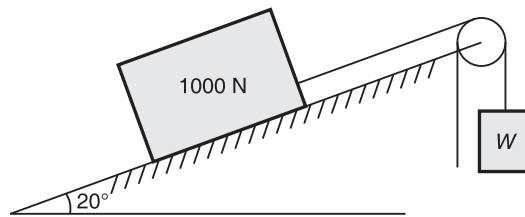

Figure 8.30 Example 8.10.

Solution Case 1: When the 1000 N block is moving in the upward direction (Figure 8.31):

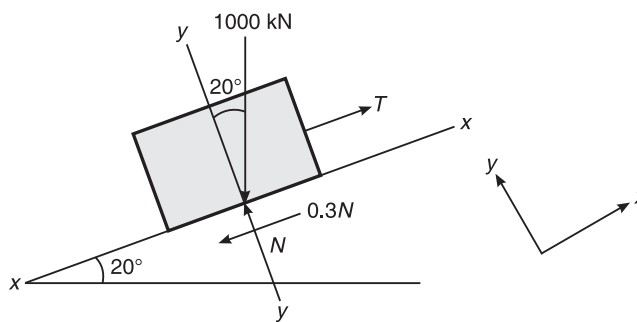

Figure 8.31 Example 8.10.

Consider the free body diagram of 1000 N block

or

$$\begin{aligned} \Sigma F_y &= 0 \\ -1000 \cos 20^\circ + N &= 0 \\ N &= 939.693 \text{ N} \end{aligned}$$

Also,

$$\Sigma F_x = 0$$

or

$$T - 0.3 \times 939.693 - 1000 \sin 20^\circ = 0$$

or

$$T = 623.928 \text{ N}$$

$$W = T$$

∴

$$W = 623.928 \text{ N}$$

Ans.

Case 2: When the 1000 N block is moving in the downward direction (Figure 8.32):

$$\Sigma F_y = 0$$

or

$$1000 \cos 20^\circ = N$$

or

$$N = 939.693 \text{ N}$$

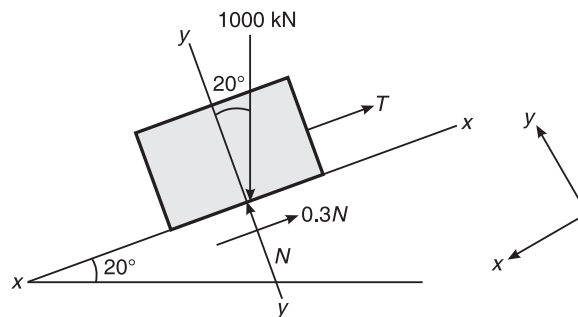

Figure 8.32 Example 8.10.

Also,

$$\Sigma F_x = 0$$

or

$$T - \mu N + 1000 \sin 20^\circ = 0$$

or

$$T = 60.112 \text{ N}$$

$$W = T$$

∴

$$W = 60.112 \text{ N}$$

Ans.

Example 8.11 Determine the necessary force P acting parallel to the plane, as shown in Figure 8.33, in order to cause motion to impend. Take $\mu = 0.25$. VTU(July 2005)

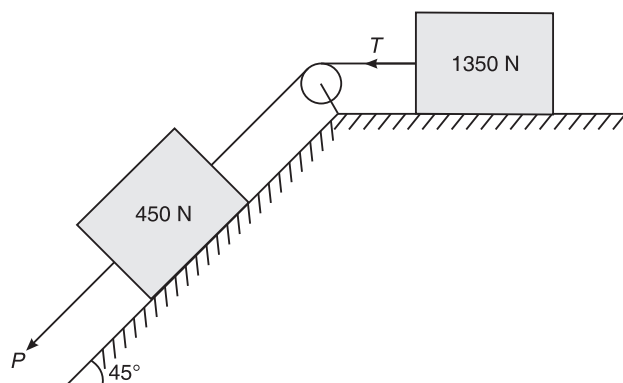

Figure 8.33 Example 8.11.

Solution Consider the free body diagram of 1350 N block (Figure 8.34):

$$\begin{aligned} \Sigma F_y &= 0 \\ \text{or} \quad N_2 &= 1350 \text{ N} \\ \text{Also,} \quad \Sigma F_x &= 0 \\ \text{or} \quad -\mu N_2 + T &= 0 \\ \text{or} \quad T &= 0.25 \times 1350 = 337.5 \text{ N} \end{aligned}$$

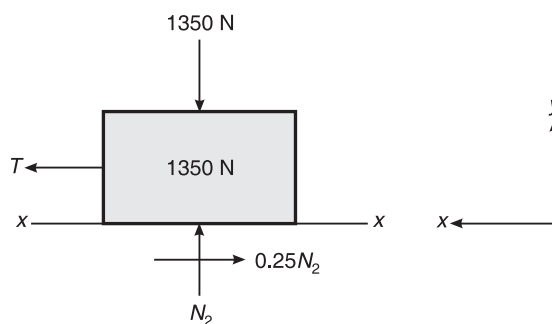

Figure 8.34 Example 8.11.

Consider the free body diagram of 450 N block (Figure 8.35):

$$\begin{aligned} \Sigma F_y &= 0 \\ \text{or} \quad -450 \cos 45^\circ + N_1 &= 0 \\ \text{or} \quad N_1 &= 450 \cos 45^\circ \\ &= 318.198 \text{ N} \\ \text{Also,} \quad \Sigma F_x &= 0 \\ \text{or} \quad -\mu N_1 + P - T + 450 \times \sin 45^\circ & \\ \text{or} \quad P &= 0.25 \times 318.198 + 337.5 - 450 \sin 45^\circ \\ &= 417.05 - 450 \sin 45^\circ \\ \text{or} \quad P &= 98.852 \text{ N} \end{aligned}$$

Ans.

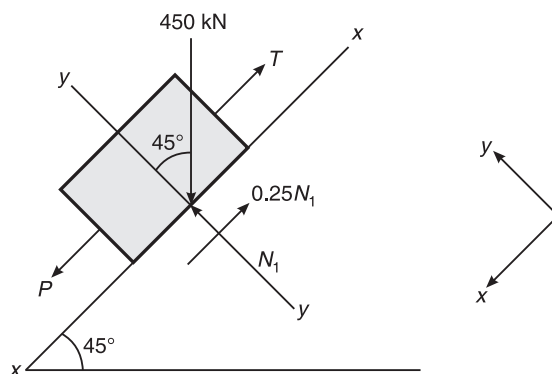

Figure 8.35 Example 8.11.

Example 8.12 Two blocks A and B weighing 4 kN and 2.5 kN, respectively, are connected by a wire passing over a smooth frictionless pulley as shown in Figure 8.36. Determine the magnitude of force P .

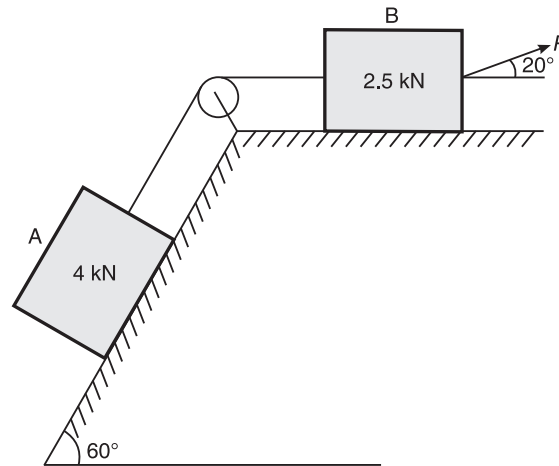

Figure 8.36 Example 8.12.

Solution Consider the free body diagram of 4 kN block (Figure 8.37):

$$\Sigma F_y = 0$$

or $N_1 - 4 \cos 60^\circ = 0$

or $N_1 = 2 \text{ kN}$

Also, $\Sigma F_x = 0$

or $T - 0.2 \times 2 - 4 \sin 60^\circ = 0$

or $T = 3.864 \text{ kN}$

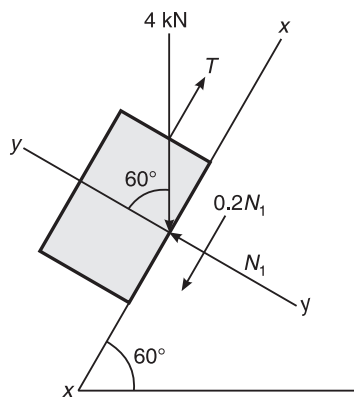

Figure 8.37 Example 8.12.

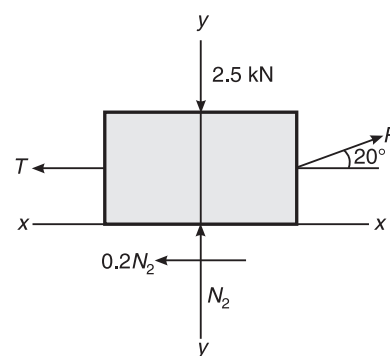

Figure 8.38 Example 8.12.

Consider the free body diagram of of 2.5 kN block (Figure 8.38):

$$\Sigma F_y = 0$$

190 ELEMENTS OF CIVIL ENGINEERING AND ENGINEERING MECHANICS

or $N_2 - 2.5 + P \sin 20^\circ = 0$

or $N_2 = 2.5 - P \sin 20^\circ$

Also, $\Sigma F_x = 0$

or $P \cos 20^\circ - 0.2(2.5 - P \sin 20^\circ) - 3.864 = 0$

or $P \cos 20^\circ - 0.5 + 0.0684P - 3.864 = 0$

or $1.008P = 4.364$

or $P = 4.329 \text{ N}$

Ans.

Example 8.13 Find the least value of P required to cause the system of blocks shown in Figure 8.39 to have impending motion to the left. Take $\mu = 0.2$.

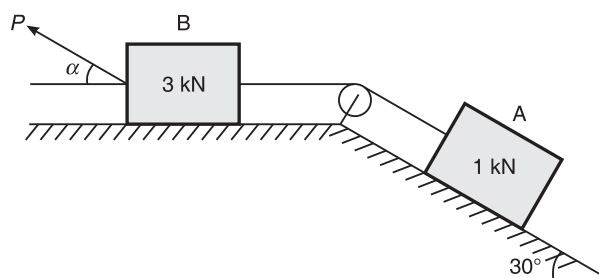

Figure 8.39 Example 8.13.

Solution Consider the free body diagram of block A (Figure 8.40):

$$\Sigma F_y = 0$$

or $N_1 - 1 \times \cos 30^\circ = 0$

or $N_1 = 0.866 \text{ kN}$

Also, $\Sigma F_x = 0$

or $T - 0.2(0.866) - 1 \times \sin 30^\circ = 0$

or $T = 0.673 \text{ kN}$

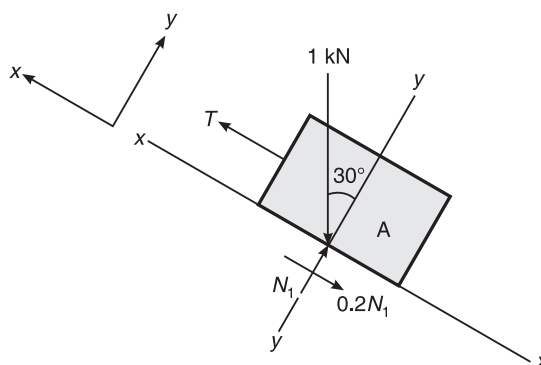

Figure 8.40 Example 8.13.

Consider the free body diagram of block B (Figure 8.41):

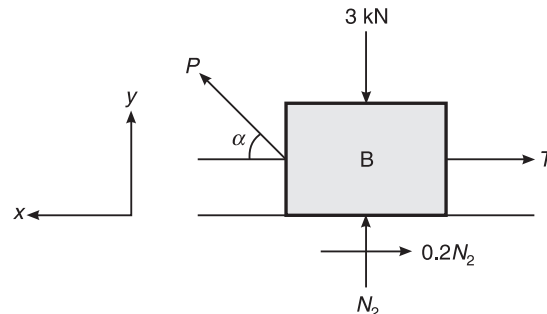

Figure 8.41 Example 8.13.

$$\Sigma F_y = 0$$

$$N_2 = 3 - P \sin \alpha$$

or

Also,

$$\Sigma F_x = 0$$

or

$$P \cos \alpha - 0.673 - 0.2(3 - P \sin \alpha) = 0$$

or

$$P \cos \alpha + 0.2P \sin \alpha - 1.273 = 0$$

or

$$P \cos \alpha + 0.2P \sin \alpha = 1.273$$

or

$$P(\cos \alpha + 0.2 \sin \alpha) = 1.273$$

or

$$P = 1.273 / (\cos \alpha + 0.2 \sin \alpha)$$

P is least, when the denominator is maximum.

Denominator is maximum when,

$$\frac{d}{d\alpha} (\cos \alpha + 0.2 \sin \alpha) = 0$$

or

$$-\sin \alpha + 0.2 \cos \alpha = 0$$

or

$$\sin \alpha = 0.2 \cos \alpha$$

or

$$\tan \alpha = 0.2$$

or

$$\alpha = \tan^{-1}(0.2)$$

$$= 11.31^\circ$$

\therefore

$$P = 1.273 / (\cos 11.31^\circ + 0.2 \sin 11.31^\circ)$$

$$= 1.248 \text{ kN}$$

Ans.

Example 8.14 Calculate the value of P required to cause the motion of the block shown in Figure 8.42. Take the coefficient of friction for all surfaces as 0.2.

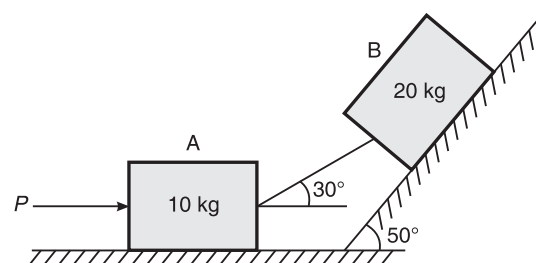

Figure 8.42 Example 8.14.

192 ELEMENTS OF CIVIL ENGINEERING AND ENGINEERING MECHANICS

Solution Consider the free body diagram of block B (Figure 8.43):

$$\begin{aligned} \Sigma F_y &= 0 \\ \text{or} \quad -20 \times 9.81 \cos 50^\circ + N_1 + T \sin 20^\circ &= 0 \\ \text{or} \quad N_1 &= 126.115 - 0.342T \\ \text{Also,} \quad \Sigma F_x &= 0 \end{aligned}$$

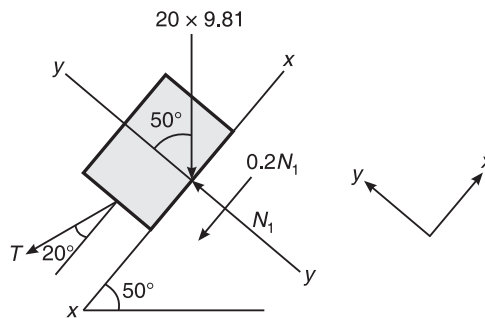

Figure 8.43 Example 8.14.

$$\begin{aligned} \text{or} \quad -20 \times 9.81 \sin 50^\circ - 0.2(126.115 - 0.342T) - T \cos 20^\circ &= 0 \\ \text{or} \quad -0.939T - 150.298 - 25.223 + 0.0684T &= 0 \\ \text{or} \quad 0.8706T &= 175.521 \\ \text{or} \quad T &= -201.609 \text{ N} \end{aligned}$$

Consider the free body diagram of block A (Figure 8.44):

$$\begin{aligned} \Sigma F_y &= 0 \\ N_2 - 10 \times 9.81 - 201.609 \times \sin 30^\circ &= 0 \\ \text{or} \quad N_2 &= 198.825 \text{ N} \\ \text{Also,} \quad \Sigma F_x &= 0 \\ \text{or} \quad -201.609 \cos 30^\circ - 0.2 \times 198.825 + P &= 0 \\ \text{or} \quad P &= 214.364 \text{ N} \end{aligned}$$

Ans.

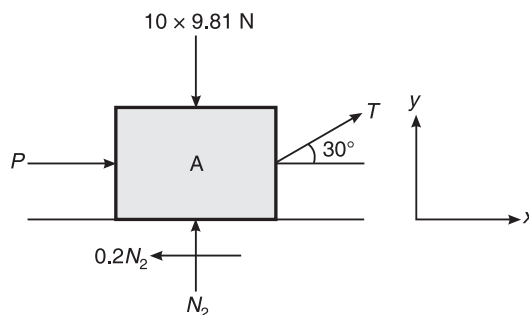

Figure 8.44 Example 8.14.

Example 8.15 Two blocks A and B of mass 30 kg and 40 kg, respectively, are connected by means of a bar placed on an inclined plane as shown in Figure 8.45. If $\mu = 0.25$, calculate the value of θ required for the motion of the block to impend.

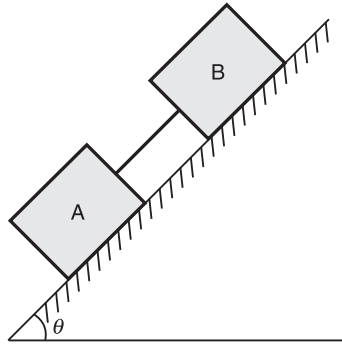

Figure 8.45 Example 8.15.

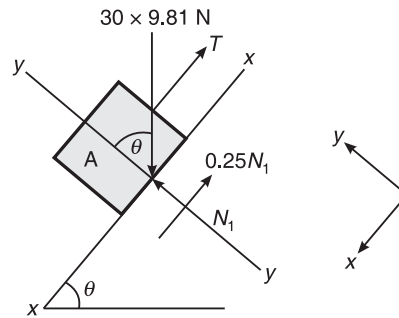

Figure 8.46 Example 8.15.

Solution Consider the free body diagram of block A (Figure 8.46):

$$\Sigma F_y = 0$$

or $N_1 - 30 \times 9.81 \cos \theta = 0$

$$N_1 = 294.3 \cos \theta$$

Also, $\Sigma F_x = 0$

or $-0.25 \times 294.3 \cos \theta - T + 30 \times 9.81 \sin \theta = 0$

or $T = 294.3 \sin \theta - 73.575 \cos \theta$

Consider the free body diagram of block B (Figure 8.47):

$$\Sigma F_y = 0$$

or $N_2 - 40 \times 9.81 \cos \theta = 0$

or $N_2 = 392.4 \cos \theta$

$$\Sigma F_x = 0$$

or $-0.25 \times 392.4 \cos \theta + T + 40 \times 9.81 \sin \theta = 0$

or $T = 98.1 \cos \theta - 392.4 \sin \theta$ (ii)

From (i) and (ii),

$$294.3 \sin \theta - 73.575 \cos \theta = 98.1 \cos \theta - 392.4 \sin \theta$$

or $686.7 \sin \theta = 171.675 \cos \theta$

or $\tan \theta = 0.25$

$\therefore \theta = 14.04^\circ$

Ans.

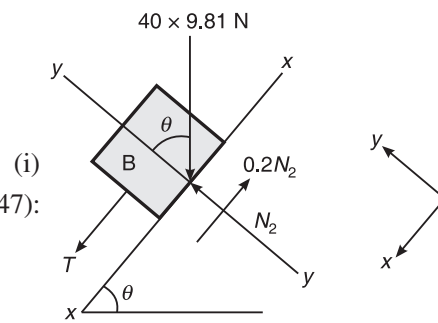

Figure 8.47 Example 8.15.

Example 8.16 Two blocks A and B connected by a horizontal link are supported on two rough planes as shown in Figure 8.48. The coefficient of friction of the block A and the horizontal plane is 0.40 and that of block B and the inclined plane is 0.36. The angle of friction for block B on the inclined plane is 20° . What is the smallest weight W_A of the block A for which the equilibrium of the system can exist?

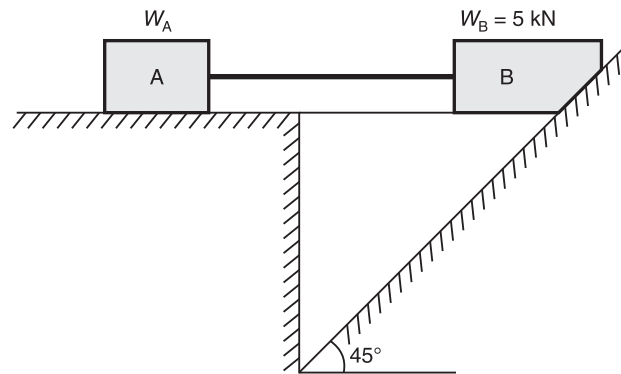

Figure 8.48 Example 8.16.

Solution Consider the free body diagram of block B (Figure 8.49):

$$\begin{aligned} \Sigma F_x &= 0 \\ \text{or} \quad T + N_1 \sin 45^\circ - 0.36N_1 \cos 45^\circ &= 0 \\ \text{or} \quad T &= -0.453N_1 \quad (i) \\ \text{Also,} \quad \Sigma F_y &= 0 \\ 5 - 0.36N_1 \sin 45^\circ - N_1 \cos 45^\circ &= 0 \\ \text{or} \quad 0.962N_1 &= 5 \\ \text{or} \quad N_1 &= 5.197 \text{ kN} \end{aligned}$$

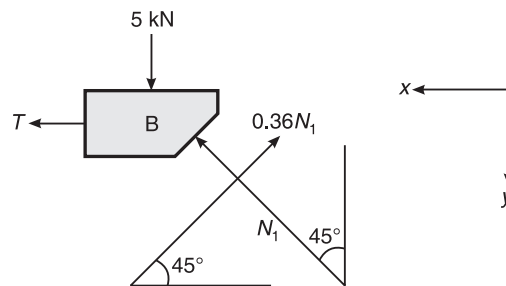

Figure 8.49 Example 8.16.

Substituting for N_1 in Eq. (i), we get

$$T = -0.453 \times 5.197 = -2.354 \text{ kN}$$

(the negative sign indicates that the horizontal link is under compression)

Now consider the free body diagram of block A (Figure 8.50):

$$\begin{aligned} \Sigma F_x &= 0 \\ \text{or} \quad -(-2.354) - 0.4N_2 &= 0 \\ \therefore N_2 &= 5.885 \text{ kN} \\ \text{Also,} \quad \Sigma F_y &= 0 \\ \text{or} \quad N_2 - W_A &= 0 \end{aligned}$$

or $W_A = N_2 = 5.885 \text{ kN}$
 \therefore Weight of the block A, i.e. $W_A = 5.885 \text{ kN}$

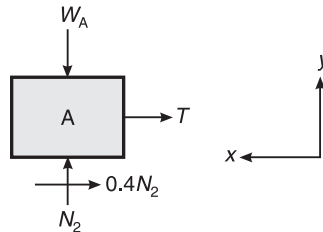

Figure 8.50 Example 8.16.

WEDGE FRICTION

A wedge is usually a triangular or trapezoidal body in action. It is used either for lifting heavy loads or for slight adjustments in the position of a body, i.e. tightening fits or keys for a shaft.

When lifting a heavy load, the wedge is placed below the load and a horizontal force P is applied as shown in Figure 8.51.

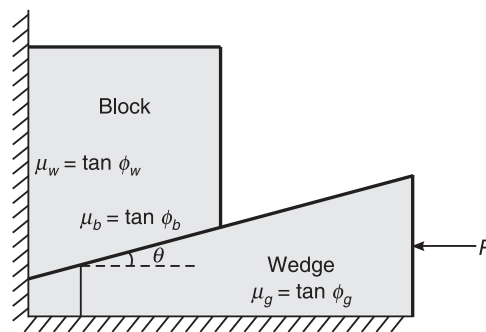

Figure 8.51 Wedge placed below the load.

The load will be resting against the wedge as shown in the above figure. As can be seen, the wedge moves from right to left lifting the block upwards, Hence the friction force reaction always opposes the impending motion and therefore the friction reaction R_w between the block and the wall is downwards, and that between the ground and the wedge R_g is acting towards left to right. The analysis of block and wedge depends on the relative motion. In case of block, it is moving from left to right relative to the motion of wedge (right to left) and hence the friction reaction is right to left, whereas for the wedge, the friction reaction is acting from left to right.

Further, the analysis of forces is easier with the Lami's theorem. It can be seen that the forces acting on both the block and wedge are a convergent system of forces and also there are three forces acting at each point O and O' respectively. As the system is in equilibrium, the Lami's theorem can be applied in succession at both the points respectively.

Consider the block first, as the number of forces acting on it is minimum (Figure 8.52). Out of the three forces, the weight of the block acts vertically downwards. The friction reaction with the wall will be acting at ϕ_w from the normal to the contact surface of wall and block, i.e normal to

the vertical surface. Finally, the third force is the friction reaction between the block and the wedge acting at ϕ_b from the normal to the contact surface, which in turn is inclined at θ (wedge angle) with the vertical.

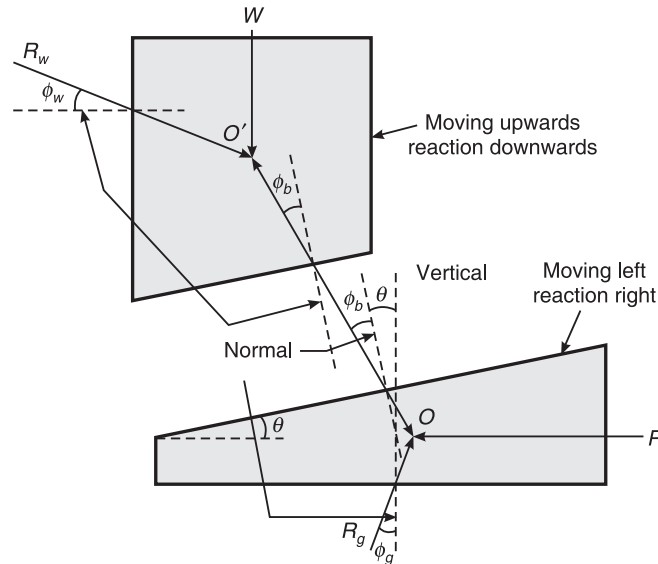

Figure 8.52 FBD of block and wedge.

Hence, the friction reaction from the wedge is inclined at an angle $(\theta + \phi_b)$ from the vertical. Following is the free body diagram at point O' (Figure 8.53).

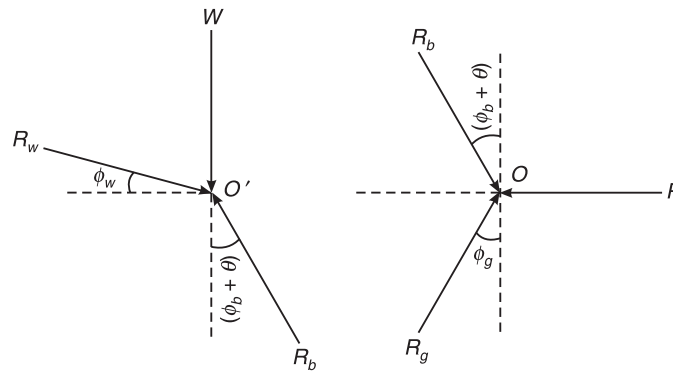

Figure 8.53 Free body diagrams at points O and O' .

Applying Lami's theorem at point O' , we get

$$\frac{W}{\sin[90 + (\phi_w + \phi_b + \theta)]} = \frac{R_b}{\sin(90 - \phi_w)} = \frac{R_w}{\sin[180 - (\phi_b + \theta)]}$$

or

$$\frac{W}{\cos(\phi_w + \phi_b + \theta)} = \frac{R_b}{\cos \phi_w} = \frac{R_w}{\sin(\phi_b + \theta)}$$

or
$$R_w = \frac{W \sin(\phi_b + \theta)}{\cos(\phi_w + \phi_b + \theta)}$$

and
$$R_b = \frac{W \cos \phi_w}{\cos(\phi_w + \phi_b + \theta)}$$

Applying Lami's theorem at point O , we get

$$\frac{P}{\sin[180 - (\phi_g + \phi_b + \theta)]} = \frac{R_b}{\sin(90 + \phi_g)} = \frac{R_g}{\sin[90 + (\phi_b + \theta)]}$$

or
$$\frac{P}{\sin(\phi_g + \phi_b + \theta)} = \frac{R_b}{\cos(\phi_g)} = \frac{R_g}{\cos(\phi_b + \theta)}$$

or
$$P = R_b \frac{\sin(\phi_g + \phi_b + \theta)}{\cos(\phi_g)}$$

and
$$R_g = P \frac{\cos(\phi_b + \theta)}{\sin(\phi_g + \phi_b + \theta)}$$

Example 8.17 A block of weight 50 kN is kept in equilibrium, by a wedge as shown in Figure 8.54. If the coefficient of friction is 0.2 for all the surfaces and the wedge has a weight of 5 kN, determine the force P necessary to cause a tendency in the block to move up.

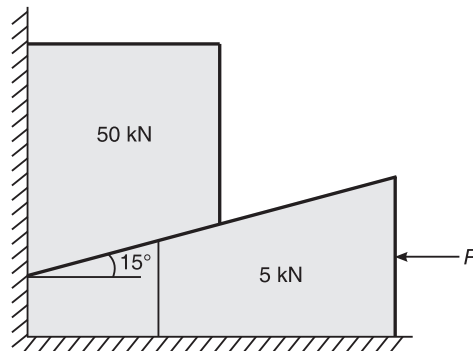

Figure 8.54 Example 8.17.

Solution $W = 50 \text{ kN}$; $w = 5 \text{ kN}$; $\theta = 15^\circ$; $\mu_w = \mu_b = \mu_g = \tan \phi = 0.2$

$\therefore \phi_w = \phi_b = \phi_g = 11.31^\circ$

Considering the free body diagram of block (Figure 8.55), we get

$$\frac{W}{\sin[90 + (\phi_w + \phi_b + \theta)]} = \frac{R_b}{\sin(90 - \phi_w)} = \frac{R_w}{\sin[180 - (\phi_b + \theta)]}$$

or
$$\frac{W}{\cos(\phi_w + \phi_b + \theta)} = \frac{R_b}{\cos \phi_w} = \frac{R_w}{\sin(\phi_b + \theta)}$$

or
$$R_w = \frac{50 \times \sin(11.31^\circ + 15^\circ)}{\cos(11.31^\circ + 11.31^\circ + 15^\circ)} = 27.98 \text{ kN}$$

and
$$R_b = \frac{50 \times \cos(11.31^\circ)}{\cos(11.31^\circ + 11.31^\circ + 15^\circ)} = 61.9 \text{ kN}$$

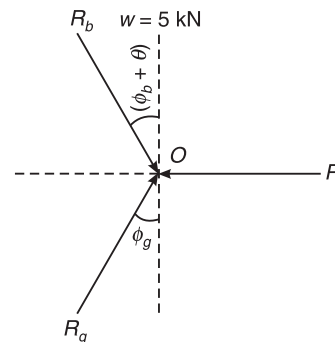
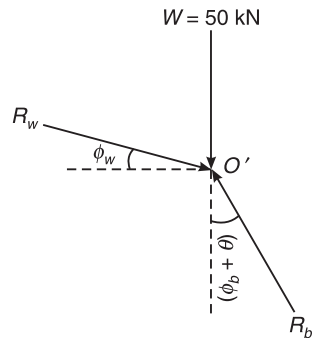

Figure 8.55 Free body diagram of the block. **Figure 8.56** Free body diagram of the wedge.

Considering the free body diagram of the wedge (Figure 8.56), we get

$$\Sigma F_y = 0 = R_g \cos \phi_g - R_b \cos(\phi_b + \theta) - w$$

or
$$w = R_g \cos(11.31^\circ) - 61.9 \times \cos(11.31^\circ + 15^\circ)$$

or
$$R_g \cos(11.31^\circ) = 61.9 \times \cos(11.31^\circ + 15^\circ) + 5$$

or
$$R_g = 61.488 \text{ kN}$$

Also,
$$\Sigma F_x = 0 = R_b \sin(\phi_b + \theta) + R_g \sin \phi_g - P$$

or
$$P = 61.9 \times \sin(11.31^\circ + 15^\circ) + R_g \sin 11.31^\circ$$

or
$$P = 27.436 + 0.196 \times 61.488 = 39.49 \text{ kN}$$

Ans.

Example 8.18 The position of machine block is adjusted by the wedge as shown in Figure 8.57. If the coefficient of friction for all the surface is 0.25, determine the force P required to raise the block.
VTU(February 2004)

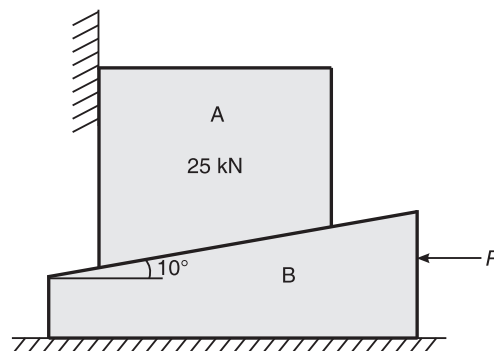

Figure 8.57 Example 8.18.

Solution Given: $\theta = 10^\circ$; $\tan \phi = 0.25$; $\phi = 14.036^\circ$; $W = 25$ kN

Considering the free body diagram of block (Figure 8.58),

$$\frac{W}{\sin[90 + (\phi_w + \phi_b + \theta)]} = \frac{R_b}{\sin(90 - \phi_w)} = \frac{R_w}{\sin[180 - (\phi_b + \theta)]}$$

or
$$\frac{W}{\cos(\phi_w + \phi_b + \theta)} = \frac{R_b}{\cos \phi_w} = \frac{R_w}{\sin(\phi_b + \theta)}$$

or
$$R_w = \frac{25 \times \sin(14.036^\circ + 10^\circ)}{\cos(14.036^\circ + 14.036^\circ + 10^\circ)} = 12.935 \text{ kN}$$

and
$$R_b = \frac{25 \times \cos 14.036^\circ}{\cos(14.036^\circ + 14.036^\circ + 10^\circ)} = 30.809 \text{ kN}$$

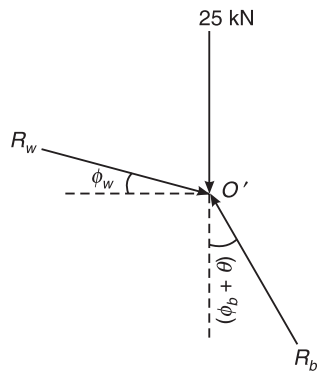

Figure 8.58 Free body diagram of block.

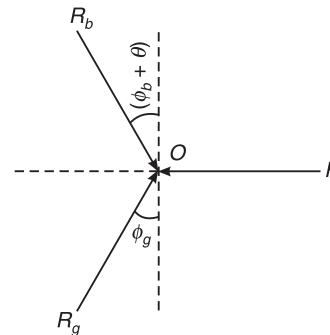

Figure 8.59 Free body diagram of wedge.

Considering the free body diagram of the wedge (Figure 8.59),

$$\frac{P}{\sin[180 - (\phi_g + \phi_b + \theta)]} = \frac{R_b}{\sin(90 + \phi_g)} = \frac{R_g}{\sin[90 + (\phi_b + \theta)]}$$

or
$$\frac{P}{\sin(\phi_g + \phi_b + \theta)} = \frac{R_b}{\cos \phi_g} = \frac{R_g}{\cos(\phi_b + \theta)}$$

or
$$P = 30.809 \times \frac{\sin(14.036^\circ + 14.036^\circ + 10^\circ)}{\cos 14.036^\circ} = 19.58 \text{ kN}$$

Ans.

or
$$R_g = 19.58 \times \frac{\cos(14.036^\circ + 10^\circ)}{\sin(14.036^\circ + 14.036^\circ + 10^\circ)} = 29 \text{ kN}$$

Example 8.19 What is the magnitude of force P required to raise the block of weight 10 kN as shown in Figure 8.60. The coefficient of friction for the entire surface is 0.25. The angle of wedge is 20° .

$$\theta = 20^\circ; \tan \phi = 0.25; \phi = 14.036^\circ; W = 10 \text{ kN.}$$

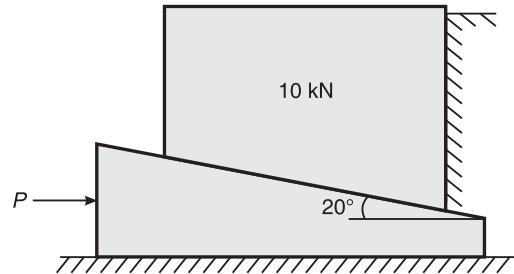

Figure 8.60 Example 8.19.

Solution Consider the free body diagram of block (Figure 8.61):

$$\frac{W}{\sin[90 + (\phi_w + \phi_b + \theta)]} = \frac{R_b}{\sin(90 - \phi_w)} = \frac{R_w}{\sin[180 - (\phi_b + \theta)]}$$

or

$$\frac{W}{\cos(\phi_w + \phi_b + \theta)} = \frac{R_b}{\cos \phi_w} = \frac{R_w}{\sin(\phi_b + \theta)}$$

$$R_w = \frac{10 \times \sin(14.036^\circ + 20^\circ)}{\cos(14.036^\circ + 14.036^\circ + 20^\circ)} = 8.377 \text{ kN}$$

and

$$R_b = \frac{10 \times \cos 14.036^\circ}{\cos(14.036^\circ + 14.036^\circ + 20^\circ)} = 14.519 \text{ kN}$$

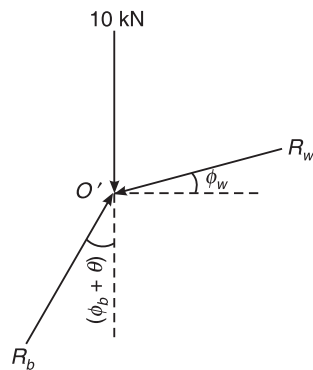

Figure 8.61 Free body diagram of block.

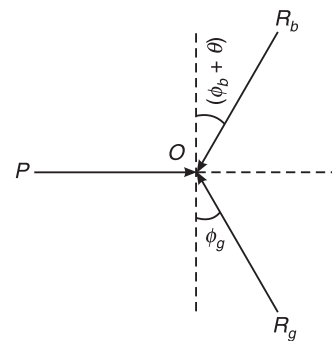

Figure 8.62 Free body diagram of wedge.

Considering the free body diagram of the wedge (Figure 8.62):

$$\frac{P}{\sin[180 - (\phi_g + \phi_b + \theta)]} = \frac{R_b}{\sin(90 + \phi_g)} = \frac{R_g}{\sin[90 + (\phi_b + \theta)]}$$

or

$$\frac{P}{\sin(\phi_g + \phi_b + \theta)} = \frac{R_b}{\cos \phi_g} = \frac{R_g}{\cos(\phi_b + \theta)}$$

or
$$P = 14.519 \times \frac{\sin(14.036^\circ + 14.036^\circ + 20^\circ)}{\cos 14.06^\circ} = 11.134 \text{ kN} \quad \text{Ans.}$$

or
$$R_g = 11.134 \times \frac{\cos(14.036^\circ + 20^\circ)}{\sin(14.036^\circ + 14.036^\circ + 20^\circ)} = 12.4 \text{ kN}$$

Example 8.20 Determine the force P required to start the movement of the wedge as shown in Figure 8.63. The angle of friction for all surfaces of contact is 15° . Given: $\theta = 20^\circ$; $\phi = 15^\circ$; $W = 20 \text{ kN}$.
VTU(January 2007)

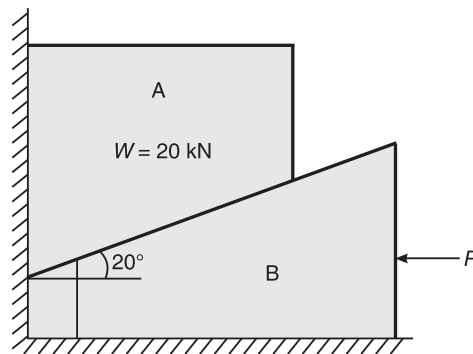

Figure 8.63 Example 8.20.

Solution Considering the free body diagram of block A (Figure 8.64), we have

$$\frac{W}{\sin[90 + (\phi_w + \phi_b + \theta)]} = \frac{R_b}{\sin(90 - \phi_w)} = \frac{R_w}{\sin[180 - (\phi_b + \theta)]}$$

or
$$\frac{W}{\cos(\phi_w + \phi_b + \theta)} = \frac{R_b}{\cos \phi_w} = \frac{R_w}{\sin(\phi_b + \theta)}$$

or
$$R_w = \frac{20 \times \sin(15^\circ + 20^\circ)}{\cos(15^\circ + 15^\circ + 20^\circ)} = 17.847 \text{ kN}$$

and
$$R_b = \frac{20 \times \cos 15^\circ}{\cos(15^\circ + 15^\circ + 20^\circ)} = 30.05 \text{ kN}$$

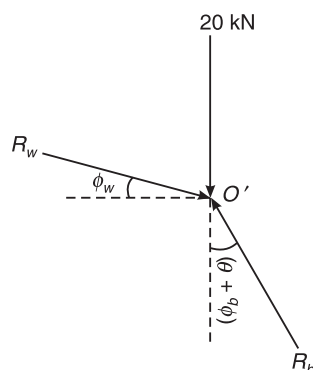

Figure 8.64 Free body diagram of block A.

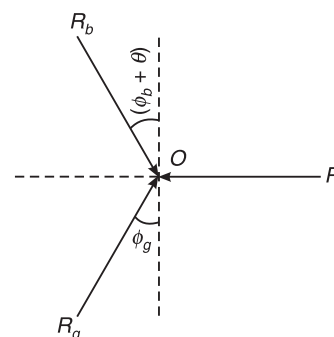

Figure 8.65 Free body diagram of wedge.

202 ELEMENTS OF CIVIL ENGINEERING AND ENGINEERING MECHANICS

Considering the free body diagram of the wedge (Figure 8.65), we have

$$\frac{P}{\sin[180 - (\phi_g + \phi_b + \theta)]} = \frac{R_b}{\sin(90 + \phi_g)} = \frac{R_g}{\sin[90 + (\phi_b + \theta)]}$$

or

$$\frac{P}{\sin(\phi_g + \phi_b + \theta)} = \frac{R_b}{\cos \phi_g} = \frac{R_g}{\cos(\phi_b + \theta)}$$

or

$$P = 30.05 \times \frac{\sin(15^\circ + 15^\circ + 20^\circ)}{\cos 15^\circ} = 23.83 \text{ kN} \quad \text{Ans.}$$

and

$$R_g = 23.83 \times \frac{\cos(15^\circ + 20^\circ)}{\sin(15^\circ + 15^\circ + 20^\circ)} = 25.48 \text{ kN}$$

LADDER FRICTION

A ladder is a device used for climbing the roofs or walls. It consists of two long uprights of wood, steel or iron pipes connected by a number of cross pieces. The friction developed between the contact surfaces of ladder and floor and also between the ladder and the wall is known as *ladder friction*.

Consider a ladder AB resting on ground and leaning against a wall as shown in Figure 8.66.

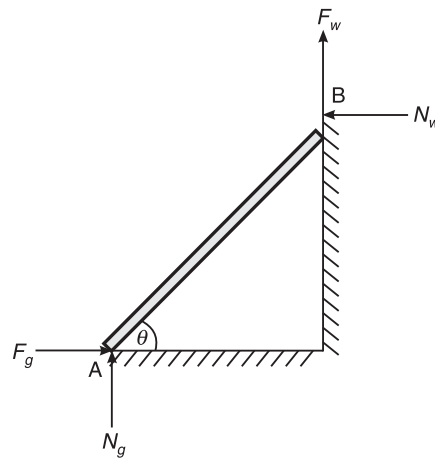

Figure 8.66 A ladder AB leaning against a wall.

As the upper end of ladder tends to slip downwards, the force of friction between the ladder and the wall will be F_w upwards. Similarly as the lower end of the ladder tends to slip away from the wall, the force F_g should be towards the wall.

Since the system is in equilibrium, the algebraic sum of the components of forces must be zero.

Example 8.21 A uniform ladder AB of length 3.25 m and weighing 250 N is placed against a smooth wall with its lower end 1.25 m from the wall (Figure 8.67). The coefficient of friction between the ladder and the floor is 0.3. What is the frictional force acting at the point of contact between the ladder and the floor? Show that the ladder will remain in equilibrium in this position.

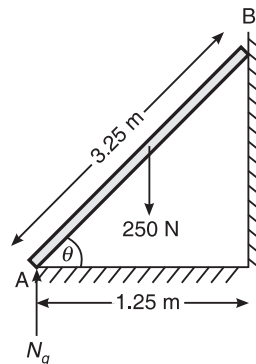

Figure 8.67 Example 8.21.

Solution

$$W = 250 \text{ N}; \mu_g = 0.3$$

$$AE = \frac{3.25}{2} = 1.625 \text{ m}$$

$$\cos \theta = \frac{AC}{AB} = \frac{1.25}{3.25} = 65.376^\circ$$

$$BC = 3.25 \times \sin 65.376^\circ = 3.0 \text{ m}$$

$$EF = \frac{3.25}{2} \times \cos 65.376^\circ = 0.625 \text{ m}$$

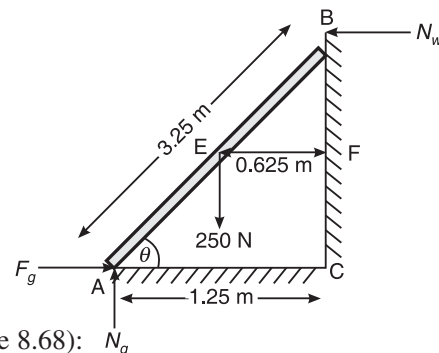

Figure 8.68 Example 8.21.

Resolving the forces in the vertical direction (Figure 8.68):

$$\Sigma F_y = 0$$

$$N_g = 250 \text{ N}$$

Taking moments about B (Figure 8.68):

$$(N_g \times 1.25) - (F_g \times 3) - (250 \times 0.625) = 0$$

or

$$F_g = 52.08 \text{ N}$$

Ans.

Equilibrium of ladder (Figure 8.68):

$$\text{Maximum frictional force} = \mu_g \times N_g = 0.3 \times 250 = 75 \text{ N}$$

Maximum $F_g >$ Actual F_g i.e. $75 > 52.08$

Therefore the body will remain in equilibrium in this position.

Example 8.22 A ladder 5 m long rests on a horizontal ground and leans against a smooth wall at an angle of 70° with the horizontal as shown in Figure 8.69. The weight of the ladder is 900 N and a man weighing 750 N stands on the ladder 1.5 m from the bottom of the ladder. Calculate the coefficient of friction between the ladder and the ground.

Solution $L = 5 \text{ m}; W = 900 \text{ N}; W_1 = 750 \text{ N}; \mu_g = ?$

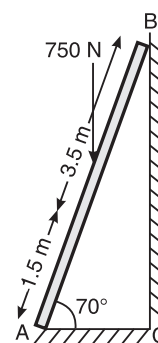

Figure 8.69 Example 8.22.

204 ELEMENTS OF CIVIL ENGINEERING AND ENGINEERING MECHANICS

$$AE = BE = \frac{1}{2} \times 5 = 2.5 \text{ m}$$

$$AD = 1.5 \text{ m and } BD = 3.5 \text{ m}$$

Let μ_g be the coefficient friction between the ladder and the ground.

$$\Sigma F_y = 0$$

$$N_g = 750 + 900 = 1650 \text{ N}$$

$$F_g = \mu_g N_g = 1650 \mu_g$$

Now taking moments about B (Figure 8.70)

$$(N_g \times 5 \cos 70^\circ) - (F_g \times 5 \sin 70^\circ)$$

$$- (750 \times BD \cos 70^\circ) - (900 \times BE \cos 70^\circ) = 0$$

$$\text{or } (1650 \times 1.710) - (\mu_g \times 1650 \times 4.698)$$

$$- (750 \times 1.197) - (900 \times 0.855) = 0$$

$$\text{or } \mu_g = 0.149$$

Ans.

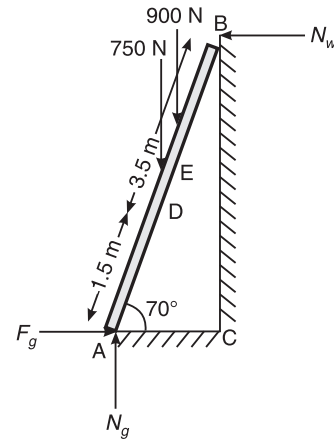

Figure 8.70 Example 8.22.

Example 8.23 A uniform ladder of 4 m length rests against a vertical wall with which it makes an angle of 45° , as shown in Figure 8.71. The coefficient of friction between the ladder and the wall is 0.4 and that between the ladder and the floor is 0.5. If the man whose weight is one-half of that of ladder ascends it, how high will he be when the ladder slips? Given: $l = 4 \text{ m}$, $\theta = 45^\circ$, $\mu_w = 0.4$, $\mu_g = 0.5$.

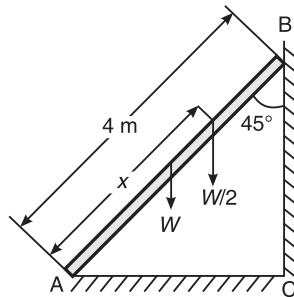

Figure 8.71 Example 8.23.

Solution Let x be distance between A and the man when the ladder is at the point of slipping (Figure 8.72).

$$W = \text{wt. of ladder}$$

$$\frac{W}{2} = \text{wt. of man}$$

From limiting friction, we have

$$F_g = \mu_g N_g = 0.5 N_g \quad (i)$$

$$F_w = \mu_w N_w = 0.4 N_w \quad (ii)$$

Resolving the forces vertically,

$$N_g + F_w = W + 0.5W = 1.5W$$

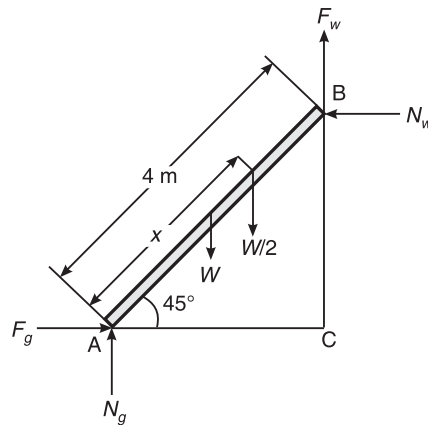

Figure 8.72 Example 8.23.

Resolving horizontally,

$$N_w = F_g = 0.5N_g$$

\therefore

$$N_g = 2N_w$$

i.e.

$$2N_w + 0.4N_w = 1.5W \quad \text{or} \quad N_w = 0.625W$$

$$F_w = 0.4 \times 0.625W = 0.25W$$

Taking moments about A and equating the same,

$$(W \times 2 \cos 45^\circ) + (0.5W \times x \cos 45^\circ) = (F_w \times 4 \sin 45^\circ) + (N_w \times 4 \times \sin 45^\circ)$$

$$(\cos 45^\circ = \sin 45^\circ, \text{ gets cancelled})$$

or

$$2W + 0.5Wx = 0.25W \times 4 + 0.625W \times 4$$

\therefore

$$x = 3.0 \text{ m}$$

Ans.

Example 8.24 A uniform ladder 4 m long weighs 200 N. It is placed against a wall making an angle of 60° with the floor as shown in Figure 8.73. The coefficient of friction between the wall and the ladder is 0.25 and that between the ground and the ladder is 0.35. The ladder in addition to its own weight, has to support a man of 1000 N at the top at B. Calculate:

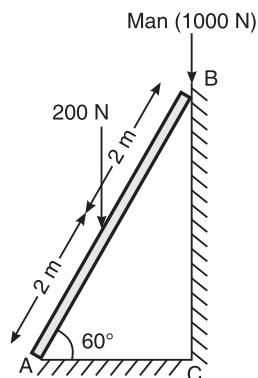

Figure 8.73 Example 8.24.

206 ELEMENTS OF CIVIL ENGINEERING AND ENGINEERING MECHANICS

- (i) The horizontal force P to be applied to the ladder at the ground level to prevent slipping.
 (ii) If the force P is not applied, what should be the minimum inclination of the ladder with the horizontal, so that it does not slip with the man at the top?

Solution (i) Horizontal force P applied to ladder at the ground level to prevent slipping (Figure 8.74):

Resolving forces horizontally,

$$P + F_g = N_w \quad \text{(i)}$$

Resolving forces vertically,

$$N_g + F_w = 200 + 1000 \quad \text{(ii)}$$

Taking moments about A,

$$(1000 \times 4 \cos 60^\circ) + (200 \times 2 \cos 60^\circ) \\ = (F_w \times 4 \cos 60^\circ) + (N_w \times 4 \sin 60^\circ)$$

or $2200 = 0.25 \times N_w \times 4 \cos 60^\circ + N_w \times 4 \sin 60^\circ$

or $N_w = 554.98 \text{ N}$

$$F_w = 0.25 \times 554.98 = 138.75 \text{ N}$$

$$N_g = 1061.25 \text{ N}$$

and $F_g = 0.35 \times 1061.25 = 371.44 \text{ N}$

$\therefore P = 554.98 - 371.44 = 183.54 \text{ N}$

Ans.

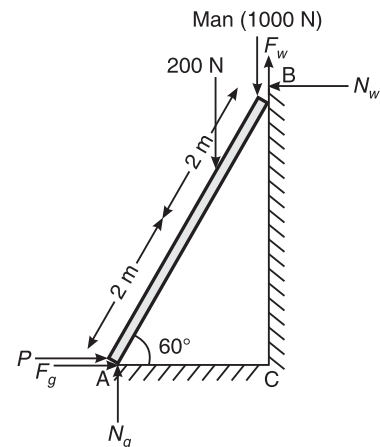

Figure 8.74 Example 8.24.

- (ii) Inclination of ladder with the horizontal (Figure 8.75):

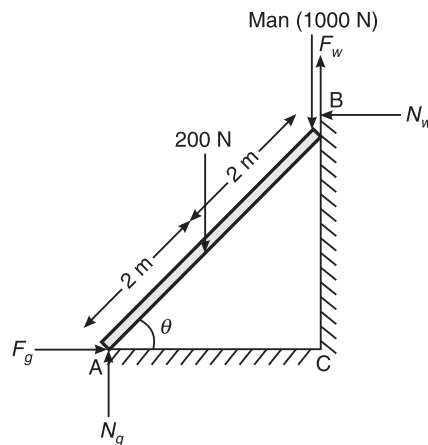

Figure 8.75 Example 8.24.

Now consider the ladder inclined at an angle θ and without any horizontal force acting at the ground level.

Resolving horizontally,

$$N_w = F_g = \mu_g N_g = 0.35 N_g$$

Resolving vertically,

$$\begin{aligned} N_g + F_w &= 1000 + 200 \\ \text{or } N_g + 0.25N_w &= 1200 \\ \text{or } N_g + 0.35 \times 0.25N_g &= 1200 \\ \text{or } N_g &= 1103.45 \text{ N} \\ \therefore N_w &= 0.35 \times 1103.45 = 386.21 \text{ N} \end{aligned}$$

Similarly, $F_w = \mu_w N_w = 0.25 \times 386.21 = 96.55 \text{ N}$

Taking moments about A and equating the same, we get

$$\begin{aligned} (1000 \times 4 \cos \theta) + (200 \times 2 \cos \theta) &= (F_w \times 4 \cos \theta) + (N_w \times 4 \sin \theta) \\ \text{or } (386.21 \times 4) \tan \theta &= 1000 \times 4 + 200 \times 2 - 96.55 \times 4 \quad (\text{dividing throughout by } \cos \theta) \\ \text{or } \tan \theta &= 2.598 \\ \therefore \theta &= 68.95^\circ \end{aligned}$$

Ans.

EXERCISE PROBLEMS

- Two blocks A and B of weight 1 kN and 2 kN respectively are in equilibrium as shown in Figure 8.76. If the coefficient of friction between the two blocks A and B and the floor is 0.3, find the force P required to move the block. **[Ans.: 1.111 kN]**

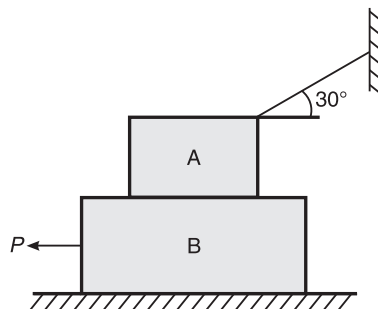

Figure 8.76

- A 200 N block is in contact with a plane inclined at 30° to the horizontal. A force P parallel to and acting up the plane is applied to the body. If $\mu_s = 0.2$ (a) find the value of P to just cause motion impend up the plane, (b) to just prevent motion down the plane. **[Ans.: (a) $P = 134.64 \text{ N}$, (b) $P = 65.35 \text{ N}$]**
- Two bodies A and B are joined by a cord parallel to the inclined plane as shown in Figure 8.77. Under body A which weighs 200 N, $\mu = 0.20$. While $\mu = 0.5$ under body B which weighs 300 N. Determine the angle θ at which the motion impends. What is the tension in the cord? **[Ans.: $\theta = 20.80^\circ$, $T = 35.4 \text{ N}$]**

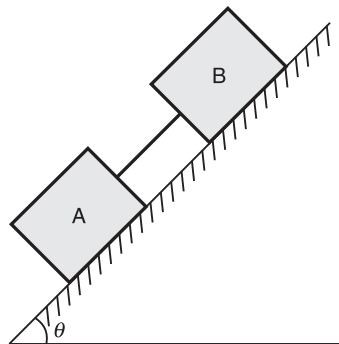

Figure 8.77

4. Find the least value of P that will just start the system blocks, shown in Figure 8.78, moving to the right. Take $\mu = 0.3$. [Ans.: $P = 247.09 \text{ N}$]

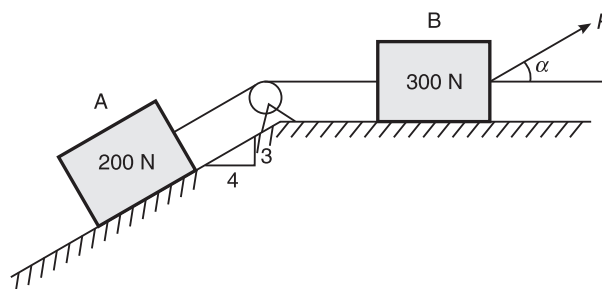

Figure 8.78

5. Two blocks P and Q are connected by a rigid bar as shown in Figure 8.79. If the weight of the block P is 2800 N, determine the minimum weight of block Q to prevent sliding. [Ans.: $W_Q = 7577.8 \text{ N}$]

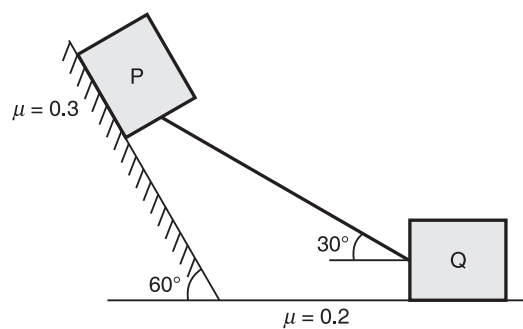

Figure 8.79

6. A uniform bar AB 10 m long and weighing 280 N is hinged at B and rests upon a 400 N block at A (Figure 8.80). If $\mu = 0.4$ at all contact surfaces, find the horizontal force P required to just start moving the 400 N block. [Ans.: 320 N]

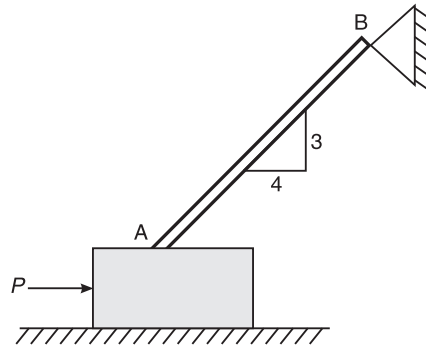

Figure 8.80

7. Find the maximum weight of the block that can be just lifted if the wedge is pushed in by a force of 2 kN in the case of the wedge–block system shown in Figure 8.81. The coefficient of friction between the block and the wall is 0.3, that between the wedge and floor is 0.20 and that of contact between block and wedge is 0.25. Neglect the weight of the wedge.

[Ans.: $W = 0.547$ kN]

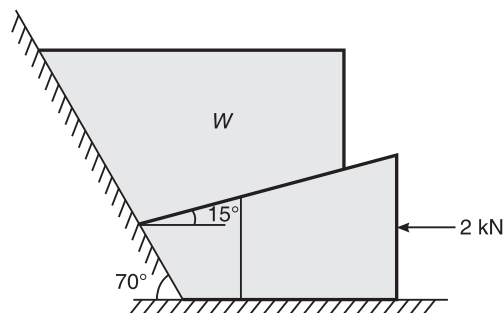

Figure 8.81

8. Determine the force P required to start the movement of the wedge as shown in Figure 8.82. The angle of friction at all contact surfaces is 15° .

[Ans.: 35.27 N]

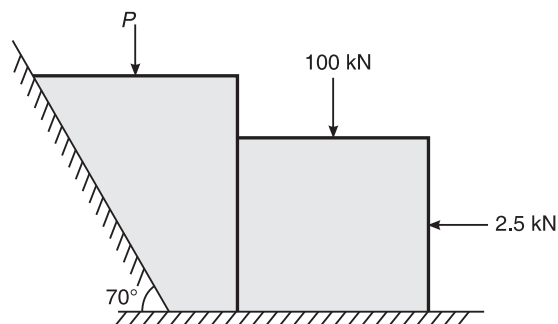

Figure 8.82

210 ELEMENTS OF CIVIL ENGINEERING AND ENGINEERING MECHANICS

9. A 4 m long ladder is supported by a wall and floor as shown in Figure 8.83. The coefficient of friction at the wall is 0.30 and that at the floor is 0.50. The weight of the ladder is 200 N. The ladder supports a vertical load of 800 N at C. Determine the reactions at the floor and wall. Compute the least value of θ at which the ladder may be placed without slipping.

[Ans.: $F_w = 130.434$ N, $\theta = 52.64^\circ$]

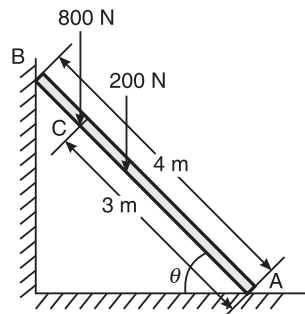

Figure 8.83

10. A ladder weighing 200 N and 4 m long is placed on the ground at an angle of 60° and the top of the ladder rests against the wall, as shown in Figure 8.84. A man weighing 1000 N stands at the top of the ladder. The coefficient of friction between the wall and the ladder is 0.30 and that between the ground and the ladder is 0.35. If the ladder is not to slip, find the horizontal force P required to be applied to the ladder at its end on the floor.

[Ans.: $P = 178.174$ N]

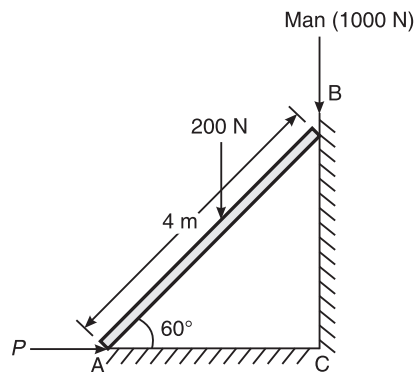

Figure 8.84

CENTROID OF PLANE FIGURES

CENTRE OF GRAVITY

It is the point where the whole weight of the body is assumed to be concentrated. It is the point on which the body can be balanced. It is the point through which the weight of the body is assumed to act. This point is usually denoted by 'C.G.' or 'G'.

CENTROID (C.G. OR G)

Centroid is the point where the whole area of the plane figure is assumed to be concentrated. The calculation of centroid means the determination of \bar{x} and \bar{y} as shown in Figure 9.1.

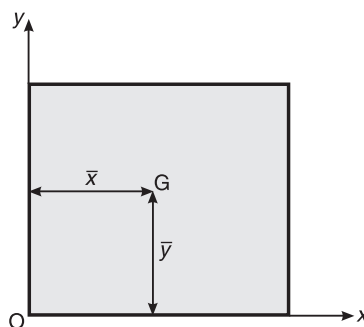

Figure 9.1 Centroid of the plane figure.

Determination of Centroid by the Method of Moments

Let us consider a body of total weight W as shown in Figure 9.2. The centre of gravity of the whole figure is located at a distance \bar{x} from the y -axis and at a distance \bar{y} from the x -axis (the point through which the total weight W acts).

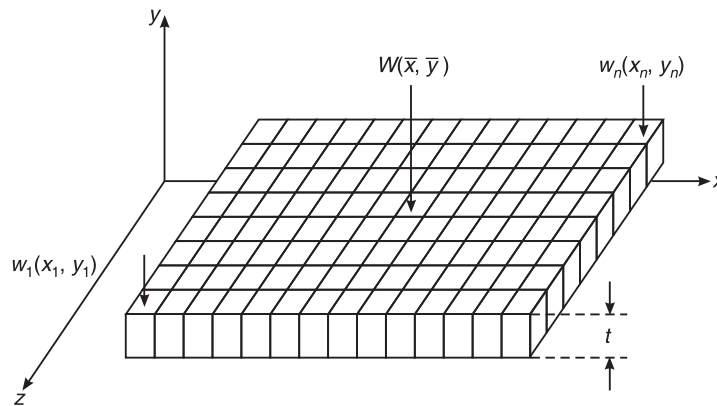

Figure 9.2 Centroid by the method of moments.

Let us divide the whole figure into a number of elemental strips of weights $w_1, w_2, w_3, w_4, \dots, w_n$ whose centroids are located at distances $x_1, x_2, x_3, \dots, x_n$ from the y -axis and $y_1, y_2, y_3, y_4, \dots, y_n$ from the x -axis.

Applying the theorem of moments about the y -axis,

$$W\bar{x} = w_1x_1 + w_2x_2 + w_3x_3 + \dots + w_nx_n$$

or

$$\bar{x} = \frac{w_1x_1 + w_2x_2 + \dots + w_nx_n}{W}$$

But if the body is homogeneous and isotropic, then the specific weight of the material is given by

$$\gamma = \frac{W}{V} = \frac{W}{A \times t}$$

where W is the weight of the body and V is the volume of the body, A is the cross-sectional area and t is the thickness which is constant.

Hence, we have

$$\bar{x} = \frac{\gamma a_1 t x_1 + \gamma a_2 t x_2 + \dots + \gamma a_n t x_n}{\gamma a_1 t + \gamma a_2 t + \dots + \gamma a_n t} = \frac{a_1 x_1 + a_2 x_2 + \dots + a_n x_n}{a_1 + a_2 + \dots + a_n} = \frac{\sum a_i x_i}{\sum a_i}$$

$$\text{Similarly, } \bar{y} = \frac{\sum a_i y_i}{\sum a_i}$$

Axes of Reference

These are the axes with respect to which the centroid of a given figure is determined.

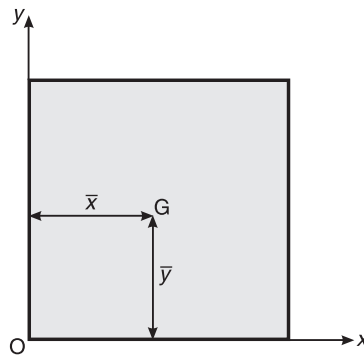

Figure 9.3 Axes of reference.

Generally the left-hand bottom corner of the plane figure is considered as the origin so that the left extreme edge and the bottom line are considered reference axes, with respect to which the centroid of the given figure is measured (Figure 9.3).

Centroidal Axis

The axis which passes through the centroid of the given figure is known as centroidal axis, such as the axis $X-X$ and the axis $Y-Y$ shown in Figure 9.4.

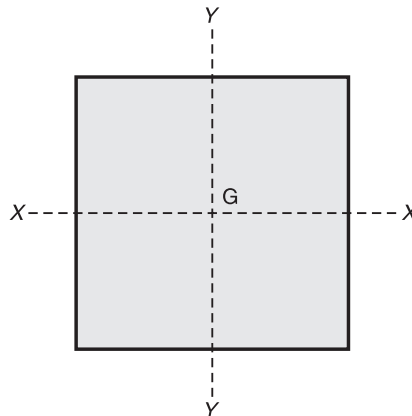

Figure 9.4 Centroidal axes.

Symmetrical Axis

It is the axis which divides the whole figure into equal parts, such as the axis $X-X$ and the axis $Y-Y$ shown in Figure 9.5.

- For a figure which is symmetrical about both the axes, $\bar{x} = 0$ and $\bar{y} = 0$.
- For a figure which is symmetrical about the $Y-Y$ axis, $\bar{x} = 0$. Such a figure which is symmetrical about the $Y-Y$ axis is shown in Figure 9.6. The area on the left-side of the $Y-Y$ axis is equal to the area on the right side of the $Y-Y$ axis.
- For a figure which is symmetrical about the $X-X$ axis, $\bar{y} = 0$. Such a figure which is symmetrical about the $X-X$ axis is shown in Figure 9.7.

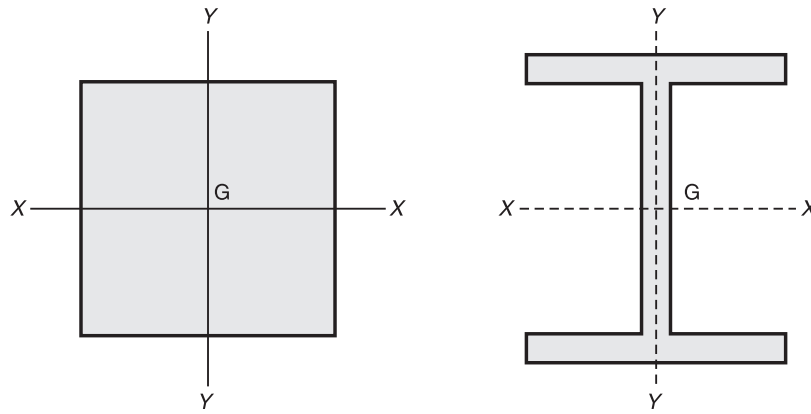

Figure 9.5 Symmetrical axes.

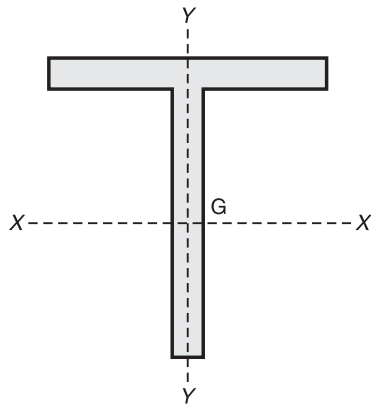

Figure 9.6 Symmetry about the Y-Y axis.

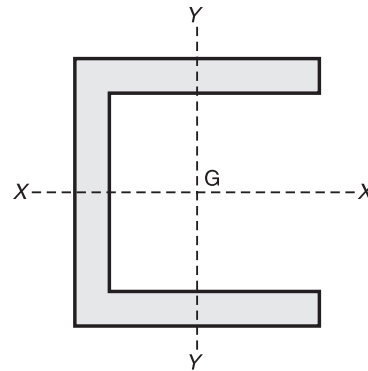

Figure 9.7 Symmetry about the X-X axis.

(d) For a figure which does not have any axis of symmetry, we calculate both \bar{x} and \bar{y} . Such a figure which does not have any axis of symmetry is shown in Figure 9.8.

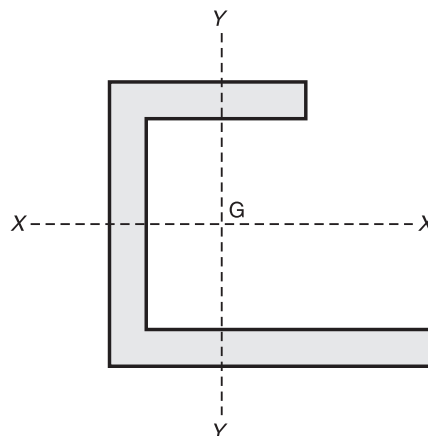
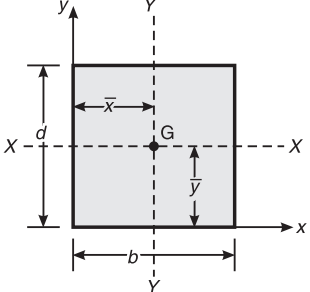
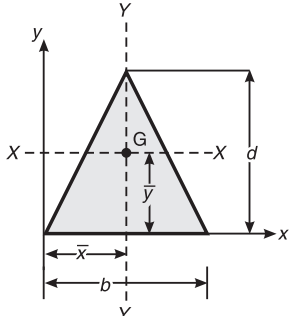
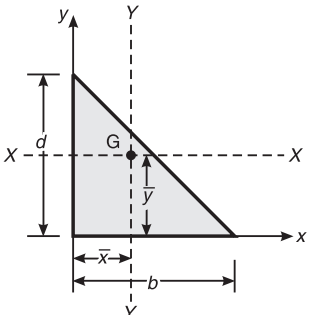
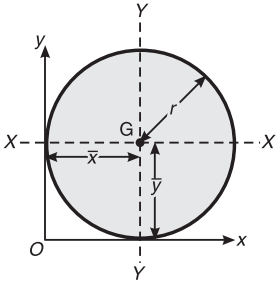

Figure 9.8 Neither the X-X axis nor the Y-Y axis is the axis of symmetry.

Centroids of Some Important Geometrical Figures

| Shape | Area | \bar{x} | \bar{y} | Figure |
|--------------------------------|------------------------------|-----------------------------|-----------------------------|---|
| Rectangle (Same for square) | bd | $\frac{b}{2}$ | $\frac{d}{2}$ |  |
| Triangle | $\left(\frac{1}{2}\right)bd$ | $\frac{b}{2}$ | $\left(\frac{1}{3}\right)d$ |  |
| Right-angled triangle | $\left(\frac{1}{2}\right)bd$ | $\left(\frac{1}{3}\right)b$ | $\left(\frac{1}{3}\right)d$ |  |
| Circle | πr^2 | $\bar{x} = r$ | $\bar{y} = r$ |  |

(Contd.)...

216 ELEMENTS OF CIVIL ENGINEERING AND ENGINEERING MECHANICS

(Contd.)...

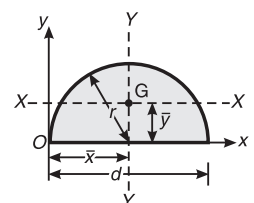
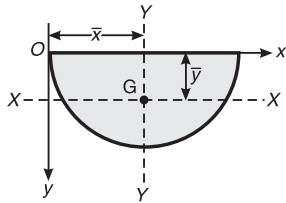
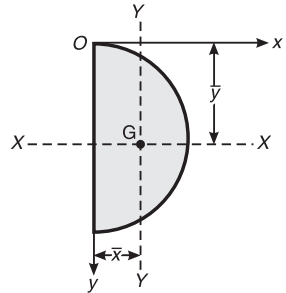
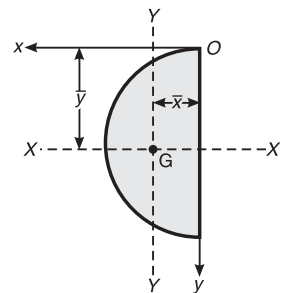
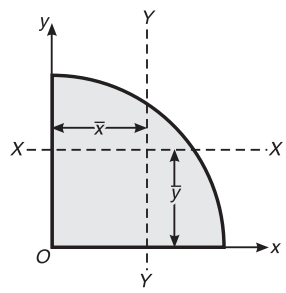
| Shape | Area | \bar{x} | \bar{y} | Figure |
|----------------|---------------------|--------------------|--------------------|---|
| Semicircle | $\frac{\pi r^2}{2}$ | $\frac{d}{2}$ | $\frac{4r}{3\pi}$ |  |
| | | $\frac{d}{2}$ | $-\frac{4r}{3\pi}$ |  |
| | | $\frac{4r}{3\pi}$ | $-\frac{d}{2}$ |  |
| | | $-\frac{4r}{3\pi}$ | $\frac{d}{2}$ |  |
| Quarter circle | $\frac{\pi r^2}{4}$ | $\frac{4r}{3\pi}$ | $\frac{4r}{3\pi}$ |  |

Reference Table

| <i>Component</i> | <i>Centroidal distance from the reference y-axis (x)</i> | <i>Centroidal distance from the reference x-axis (y)</i> | <i>Area (a)</i> | <i>ax</i> | <i>ay</i> |
|---|--|--|-----------------|-------------|-------------|
| $\bar{x} = \frac{\Sigma ax}{\Sigma a}$ $\bar{y} = \frac{\Sigma ay}{\Sigma a}$ | | | | | |
| where $\Sigma ax = a_1x_1 + a_2x_2 + a_3x_3 + \dots$ $\Sigma ay = a_1y_1 + a_2y_2 + a_3y_3 + \dots$ $\Sigma a = a_1 + a_2 + a_3 + \dots$ | | | | | |
| Total | | | Σa | Σax | Σay |

Derivation of Centroid of Some Important Geometrical Figures**Rectangle**

Let us consider a rectangular lamina of area $b \times d$ as shown in Figure 9.9. Now consider a horizontal elementary strip of area $b \times dy$, which is at a distance y from the reference axis AB.

Moment of area of elementary strip about AB

$$= b \times dy \times y$$

Sum of moments of such elementary strips about AB is given by

$$\begin{aligned} & \int_0^d b \times dy \times y \\ &= b \int_0^d y \cdot dy \\ &= b \times \left[\frac{y^2}{2} \right]_0^d \\ &= \frac{bd^2}{2} \end{aligned}$$

Moment of total area about AB = $bd \times \bar{y}$
Apply the principle of moments about AB,

$$\frac{bd^2}{2} = bd \times \bar{y} \quad \text{or} \quad \bar{y} = \frac{d}{2}$$

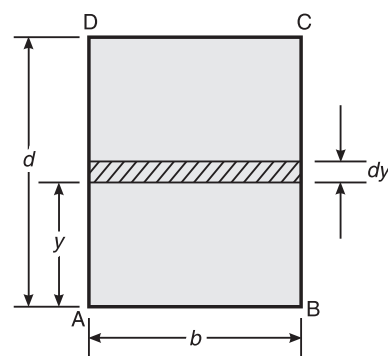

Figure 9.9 Rectangular lamina.

By considering a vertical strip, similarly, we can prove that

$$\bar{x} = \frac{b}{2}$$

Triangle

Consider a triangular lamina of area $(1/2) \times b \times d$ as shown in Figure 9.10.

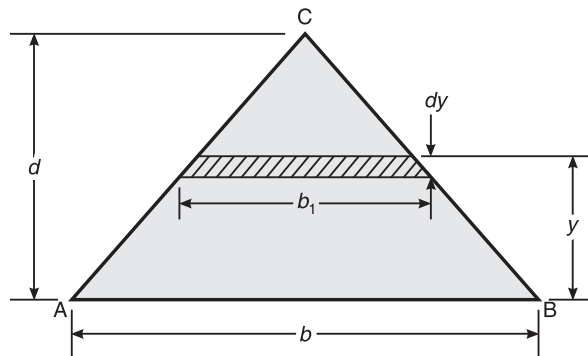

Figure 9.10 Triangular lamina.

Now consider an elementary strip of area $b_1 \times dy$ which is at a distance y from the reference axis AB.

Using the property of similar triangles, we have

$$\frac{b_1}{b} = \frac{d-y}{d}$$

or

$$b_1 = \frac{(d-y)b}{d}$$

$$\text{Area of the elementary strip} = b_1 \times dy = \frac{(d-y)b \cdot dy}{d}$$

Moment of area of elementary strip about AB

$$\begin{aligned} &= \text{area} \times y \\ &= \frac{(d-y)b \cdot dy \cdot y}{d} \\ &= \frac{b \cdot dy \cdot d \cdot y}{d} - \frac{by^2 \cdot dy}{d} \\ &= by \cdot dy - \frac{by^2 \cdot dy}{d} \end{aligned}$$

Sum of moments of such elementary strips is given by

$$\int_0^d by \cdot dy - \int_0^d \frac{by^2}{d} \cdot dy$$

$$\begin{aligned}
 &= b \times \left[\frac{y^2}{2} \right]_0^d - \frac{b}{d} \left[\frac{y^3}{3} \right]_0^d \\
 &= \frac{bd^2}{2} - \frac{bd^3}{3d} \\
 &= \frac{bd^2}{2} - \frac{bd^2}{3} \\
 &= \frac{bd^2}{6}
 \end{aligned}$$

Moment of total area about AB = $\frac{1}{2}bd \times \bar{y}$

Applying the principle of moments,

$$\frac{bd^2}{6} = \frac{1}{2} \times bd \times \bar{y}$$

$$\therefore \bar{y} = \frac{d}{3}$$

Semicircle

Consider a semicircular lamina of area $\frac{\pi r^2}{2}$ as shown in Figure 9.11. Now consider a triangular elementary strip of area $\frac{1}{2} \times R \times R \times d\theta$ at an angle of θ from the x -axis, whose centre of gravity

is at a distance of $\frac{2}{3}R$ from O and its projection on the x -axis = $\left(\frac{2}{3}\right)R \cos \theta$.

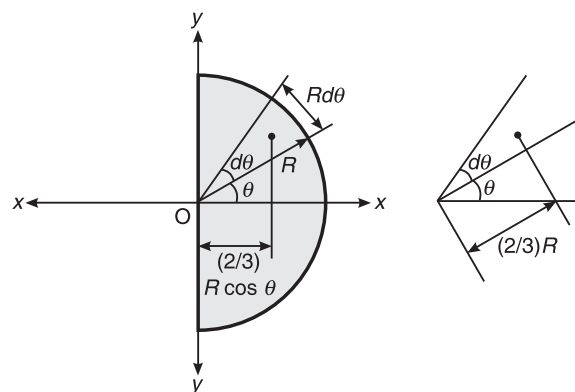

Figure 9.11 Semicircular lamina.

$$\begin{aligned} \text{Moment of area of elementary strip about the y-axis} &= \frac{1}{2} \times R^2 \cdot d\theta \cdot \left(\frac{2}{3}\right) R \cos \theta \\ &= \frac{R^3 \cdot \cos \theta \cdot d\theta}{3} \end{aligned}$$

Sum of moments of such elementary strips about the y-axis

$$\begin{aligned} &= \int_{-\pi/2}^{\pi/2} \frac{R^3}{3} \cos \theta \cdot d\theta \\ &= \frac{R^3}{3} [\sin \theta]_{-\pi/2}^{\pi/2} \\ &= \frac{R^3}{3} \left[\sin \frac{\pi}{2} + \sin \frac{\pi}{2} \right] = \frac{2R^3}{3} \end{aligned}$$

Moment of total area about the y-axis

$$= \frac{\pi R^2}{2} \times \bar{x}$$

Using the principle of moments

$$\frac{2R^3}{3} = \frac{\pi R^2}{2} \times \bar{x}$$

\therefore

$$\bar{x} = \frac{2R^3 \times 2}{3R^2\pi}$$

or

$$\bar{x} = \frac{4R}{3\pi}$$

Quarter circle

Consider a quarter circular lamina of area $\frac{\pi R^2}{4}$ as shown in Figure 9.12. Consider a triangular elementary strip of area $\frac{1}{2} \times R \times R \times d\theta$ at an angle of θ from the x-axis, whose centre of gravity is at a distance of $\frac{2}{3} R$ from O and its projection on x-axis = $\frac{2}{3} R \cos \theta$.

Moment of area of elementary strip about the y-axis

$$= \frac{2}{3} R \cos \theta \times \frac{1}{2} \times R^2 \cdot d\theta = \frac{R^3 \cdot \cos \theta \cdot d\theta}{3}$$

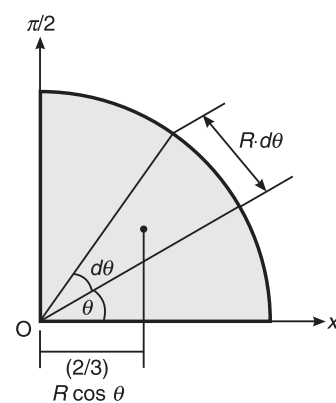

Figure 9.12 Quarter circular lamina.

Sum of moments of such elementary strips about the y-axis

$$\begin{aligned} &= \int_0^{\pi/2} \frac{R^3}{3} \cos \theta \cdot d\theta \\ &= \frac{R^3}{3} \left[\sin \frac{\pi}{2} \right] \\ &= \frac{R^3}{3} \end{aligned}$$

Moment of total area about the y-axis

$$= \frac{\pi R^2}{4} \times \bar{x}$$

Using the principle of moments,

$$\frac{R^3}{3} = \frac{\pi R^2}{4} \times \bar{x}$$

\therefore

$$\bar{x} = \frac{4R^3 \times 2}{3R^2 \pi}$$

or

$$\bar{x} = \frac{4R}{3\pi}$$

Similarly, we can prove that $\bar{y} = \frac{4R}{3\pi}$.

Sector of a circle

Consider a sector of a circular lamina as shown in Figure 9.13.

Consider a triangular elementary strip of area $\frac{1}{2} \times R \times R \times d\theta$ at an angle of θ from the x-axis, whose centre of gravity is at a distance of $\frac{2}{3}$ from O and its projection on x-axis = $\frac{2}{3} R \cos \theta$.

$$\text{Area of strip} = \frac{1}{2} \times R^2 d\theta$$

Area of sector is given by

$$\int_0^{\alpha} \frac{1}{2} \times R^2 d\theta = \frac{1}{2} \times R^2 \alpha$$

Moment of area of elementary strip about y-axis

$$= \frac{2}{3} R \cos \theta \times \frac{1}{2} \times R^2 d\theta = \frac{R^3 \cdot \cos \theta \cdot d\theta}{3}$$

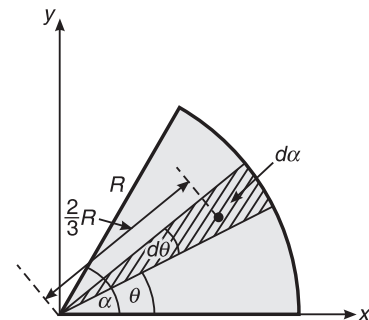

Figure 9.13 Sector of a circle.

222 ELEMENTS OF CIVIL ENGINEERING AND ENGINEERING MECHANICS

Sum of moments of such elementary strips about y-axis

$$= \int_0^\alpha \frac{R^3}{3} \cos \theta \cdot d\theta$$

$$= \frac{R^3}{3} (\sin \alpha)$$

Moment of total area about y-axis

$$= \frac{R^2 \alpha}{2} \times \bar{x}$$

Using the principle of moments,

$$\frac{R^3}{3} \sin \alpha = \frac{R^2 \alpha}{2} \times \bar{x}$$

or

$$\bar{x} = \frac{2R}{3} \sin \alpha$$

Moment of area of elementary strip about x-axis

$$= \frac{2}{3} R \sin \theta \times \frac{1}{2} \times R^2 \cdot d\theta = \frac{R^3 \cdot \sin \theta \cdot d\theta}{3}$$

Sum of moments of such elementary strips about y-axis

$$= \int_0^\alpha \frac{R^3}{3} \sin \theta \cdot d\theta$$

$$= \frac{R^3}{3} [-\cos \theta]_0^\alpha = \frac{R^3}{3} (1 - \cos \alpha)$$

Moment of total area about y-axis = $\frac{R^2 \alpha}{2} \times \bar{y}$

Using the principle of moments,

$$\frac{R^3}{3} (1 - \cos \alpha) = \frac{R^2 \alpha}{2} \times \bar{y}$$

or

$$\bar{y} = \frac{2R}{3} (1 - \cos \alpha)$$

Problems on Centroid**Tips to solve problems**

1. The centroid always lies on the symmetrical axis.
2. Identify the symmetrical axes, if any. Chose them as the reference axes. If no symmetrical axis is available, choose the left-hand bottom corner of the given figure as the origin so that the entire figure lies in the first quadrant (to avoid the negative centroidal values).

3. Sub-divide the given figure into known geometrical shapes and identify their individual centroids by denoting them with C_i where i is the number of the sub-divided shapes.
4. Enter the values in tabular columns as shown below:

| <i>Component</i> | <i>Area (a)</i> | <i>Centroidal distance from y-axis (x)</i> | <i>Centroidal distance from x-axis (y)</i> | <i>ax</i> | <i>ay</i> |
|------------------|-----------------|--|--|-------------|-------------|
| Sum | Σa | | | Σax | Σay |

5. Indicate the calculations like enter the $x \times y$ values for area and then enter the result (do not enter the result directly). For the centroidal distances, enter the equation with the substituted numerical values like $3 + \frac{4 \times 5}{3\pi}$ etc. The areas are negative if hollow and the centroidal values are negative if they are below the x -axis or left of the y -axis.
6. Compute the centroidal values as $\bar{x} = \frac{\Sigma ax}{\Sigma a}$ and $\bar{y} = \frac{\Sigma ay}{\Sigma a}$.
7. The centroidal value of a triangle is always $\frac{1}{3}$ rd the length from the base and $\frac{2}{3}$ rd the height from the apex.
8. The centroidal value of a semicircle is always measured as $\frac{4r}{3\pi}$ from the base of the semicircle (normal to base) or along the symmetrical axis.

For example, to find the centroid of Figure 9.14, we proceed to tabulate the results as follows:

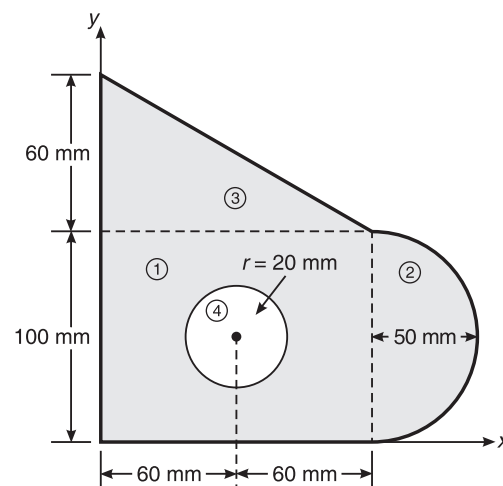

Figure 9.14

224 ELEMENTS OF CIVIL ENGINEERING AND ENGINEERING MECHANICS

| Component | Area (mm^2) | x (mm) | y (mm) | ax | ay |
|--------------|--|----------------------------------|-------------------------------|--------------|-------------|
| Rectangle 1 | $120 \times 100 = 12,000$ | $\frac{120}{2} = 60$ | $\frac{100}{2} = 50$ | 720,000 | 600,000 |
| Semicircle 2 | $\frac{\pi \times 50^2}{2} = 3926.9$ | $120 + \frac{4 \times 50}{3\pi}$ | $\frac{100}{2} = 50$ | 554,569.53 | 196,349.5 |
| Triangle 3 | $\frac{1}{2} \times 120 \times 60 = 360$ | $\frac{1}{3} \times 120 = 40$ | $100 + \frac{1}{3} \times 60$ | 144,000 | 432,000 |
| Circle 4 | $-\pi \times 20^2 = -1256.64$ | 60 | $\frac{100}{2} = 50$ | -75,398.4 | -62,832 |
| Sum | 18,270.35 | | | 1,343,171.13 | 1,165,517.5 |

$$\bar{x} = \frac{\Sigma ax}{\Sigma a} = \frac{1,343,171.13}{18,270.35} = 73.52 \text{ mm}$$

and

$$\bar{y} = \frac{\Sigma ay}{\Sigma a} = \frac{1,165,517.5}{18,270.35} = 63.79 \text{ mm}$$

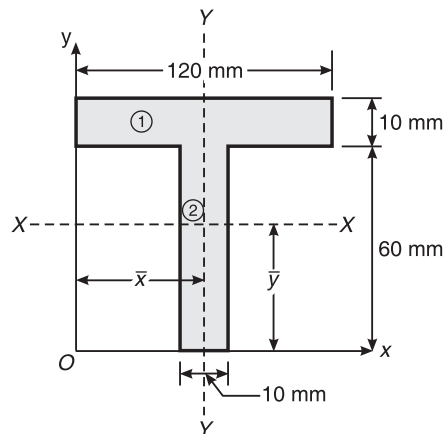
Example 9.1 Find the centroid of Figure 9.15.**Figure 9.15** Example 9.1.**Solution**

| Component (Figure 9.16) | Area, $a(mm^2)$ | Centroidal distance from y -axis (x) | Centroidal distance from x -axis (y) | ax | ay |
|----------------------------|------------------------|--|--|---------|--------|
| Rectangle 1 | $120 \times 10 = 1200$ | $\frac{120}{2} = 60$ | $60 + \frac{10}{2} = 65$ | 72,000 | 78,000 |
| Rectangle 2 | $10 \times 60 = 600$ | $\frac{120}{2} = 60$ | $\frac{60}{2} = 30$ | 36,000 | 18,000 |
| Sum | $\Sigma a = 1800$ | | | 108,000 | 96,000 |

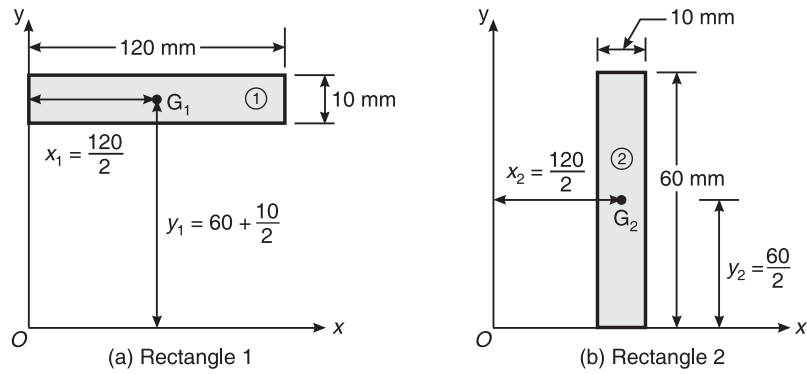

Figure 9.16 Example 9.1.

$$\bar{x} = \frac{\Sigma ax}{\Sigma a} = \frac{108,000}{1800} = 60 \text{ mm}$$
$$\bar{y} = \frac{\Sigma ay}{\Sigma a} = \frac{96,000}{1800} = 53.33 \text{ m}$$

Ans.

The given figure is symmetrical about the y -axis, so \bar{x} can be directly written as 60 mm.

Example 9.2 Find the centroid of Figure 9.17.

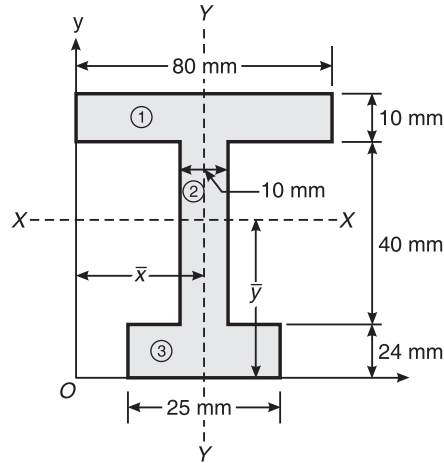

Figure 9.17 Example 9.2.

The given figure is symmetrical about the Y - Y axis and hence we consider it as the reference y -axis.

226 ELEMENTS OF CIVIL ENGINEERING AND ENGINEERING MECHANICS

Solution

| Component (Figure 9.18) | Area, a | Centroidal distance from the x -axis (y) | a | y |
|----------------------------|----------------------|--|-----|----------------------|
| Rectangle 1 | $10 \times 80 = 800$ | $24 + 40 + \frac{10}{2} = 69$ | 800 | 55,200 |
| Rectangle 2 | $10 \times 40 = 400$ | $24 + \frac{40}{2} = 44$ | 400 | 17,600 |
| Rectangle 3 | $25 \times 24 = 600$ | $\frac{24}{2} = 12$ | 600 | 7,200 |
| Sum | $\Sigma a = 1800$ | | | $\Sigma ay = 80,000$ |

$$\bar{y} = \frac{\Sigma ay}{\Sigma a} = \frac{80,000}{1800} = 44.44 \text{ mm}; \quad \bar{x} = \frac{80}{2} = 40 \text{ mm} \quad \text{Ans.}$$

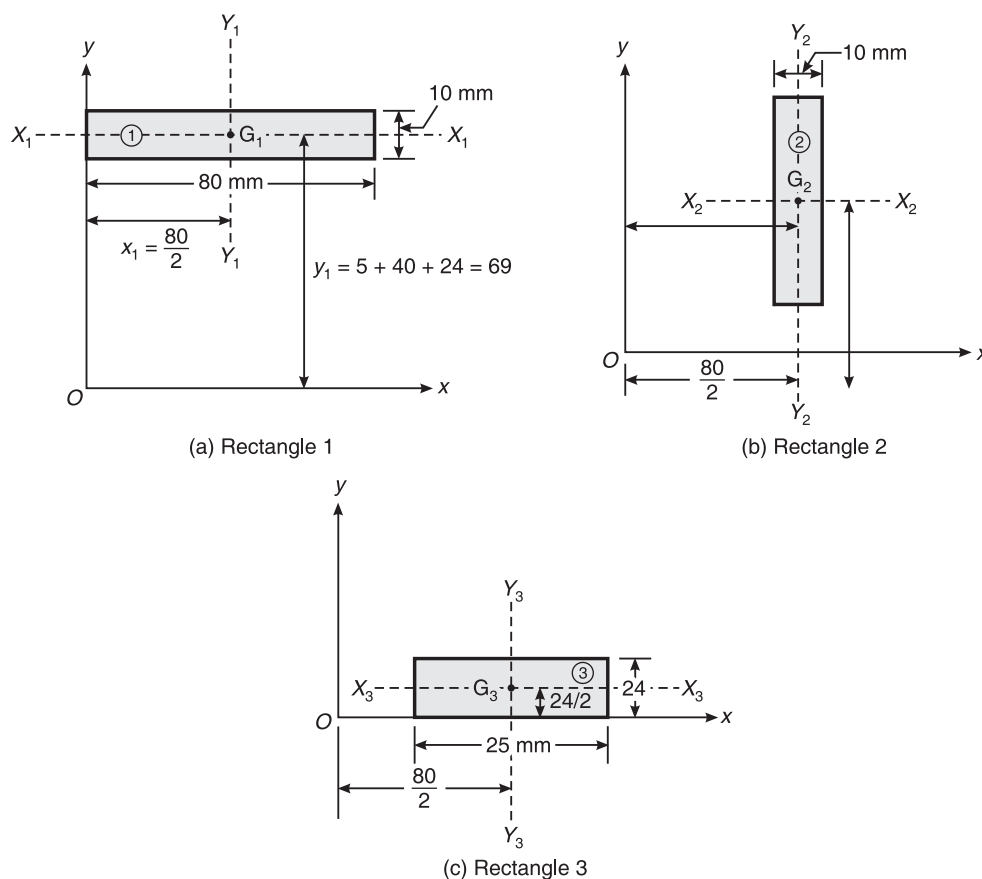
**Figure 9.18** Example 9.2.

Example 9.3 Determine the centroid of Figure 9.19.

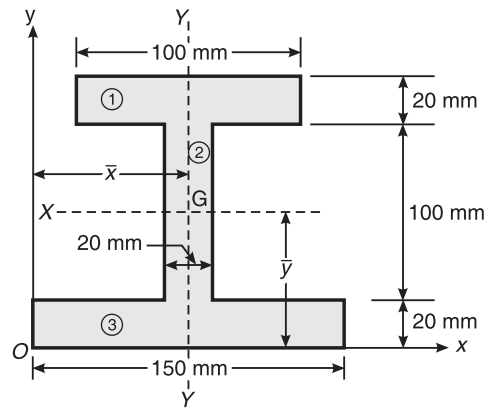

Figure 9.19 Example 9.3.

Solution

| Component | Area, a | y | ay |
|-------------|------------------------|---------------------------------|-----------------------|
| Rectangle 1 | $100 \times 20 = 2000$ | $20 + 100 + \frac{20}{2} = 130$ | 260,000 |
| Rectangle 2 | $100 \times 20 = 2000$ | $20 + \frac{100}{2} = 70$ | 140,000 |
| Rectangle 3 | $150 \times 20 = 3000$ | $\frac{20}{2} = 10$ | 30,000 |
| Sum | $\Sigma a = 7000$ | | $\Sigma ay = 430,000$ |

$$\bar{y} = \frac{\Sigma ay}{\Sigma a} = \frac{430,000}{7000} = 61.429 \text{ mm}; \quad \bar{x} = \frac{150}{2} = 75 \text{ mm}$$

Ans.

Example 9.4 Determine the centroid of Figure 9.20.

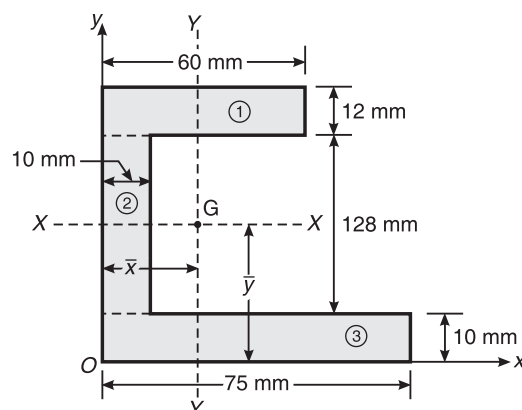

Figure 9.20 Example 9.4.

228 ELEMENTS OF CIVIL ENGINEERING AND ENGINEERING MECHANICS

| Component | Area, a | x | y | ax | ay |
|-------------|------------------------|-----------------------|---------------------------------|----------------------|-----------------------|
| Rectangle 1 | $60 \times 12 = 720$ | $\frac{60}{2} = 30$ | $10 + 128 + \frac{12}{2} = 144$ | 21,600 | 103,680 |
| Rectangle 2 | $10 \times 128 = 1280$ | $\frac{10}{2} = 5$ | $10 + \frac{128}{2} = 74$ | 6400 | 94,720 |
| Rectangle 3 | $10 \times 75 = 750$ | $\frac{75}{2} = 37.5$ | $\frac{10}{2} = 5$ | 28,125 | 3750 |
| Sum | $\Sigma a = 2750$ | | | $\Sigma ax = 56,125$ | $\Sigma ay = 202,150$ |

$$\bar{x} = \frac{\Sigma ax}{\Sigma a} = \frac{56,125}{2750} = 20.409 \text{ mm}; \quad \bar{y} = \frac{\Sigma ay}{\Sigma a} = \frac{202,150}{2750} = 73.509 \text{ mm} \quad \text{Ans.}$$

Example 9.5 Determine the centroid of Figure 9.21.

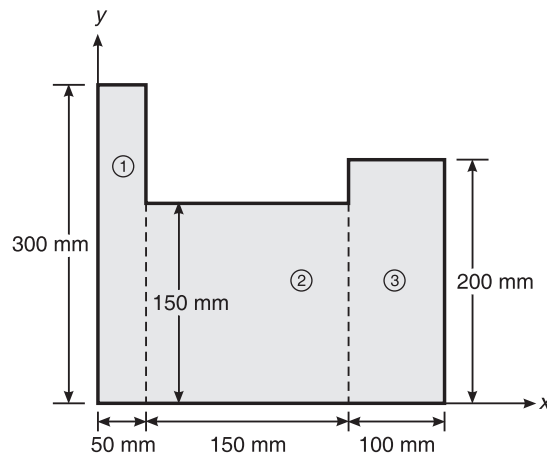

Figure 9.21 Example 9.5.

Solution

| Component | Area, a | x | y | ax | ay |
|-------------|---------------------------|-----------------------------|-----------------------|------------------------------|------------------------------|
| Rectangle 1 | $50 \times 300 = 15,000$ | $\frac{50}{2} = 25$ | $\frac{300}{2} = 150$ | 375,000 | 2,250,000 |
| Rectangle 2 | $150 \times 150 = 22,500$ | $50 + \frac{150}{2} = 125$ | $\frac{150}{2} = 75$ | 2,812,500 | 1,687,500 |
| Rectangle 3 | $200 \times 100 = 20,000$ | $200 + \frac{100}{2} = 250$ | $\frac{200}{2} = 100$ | 5,000,000 | 2,000,000 |
| Sum | Σa $= 57,500$ | | | Σax $= 8,187,500$ | Σay $= 5,937,500$ |

$$\bar{x} = \frac{\Sigma ax}{\Sigma a} = \frac{8,187,500}{57,500} = 142.391 \text{ mm}; \quad \bar{y} = \frac{\Sigma ay}{\Sigma a} = \frac{5,937,500}{57,500} = 103.261 \text{ mm} \quad \text{Ans.}$$

Example 9.6 Determine the centroid of Figure 9.22.

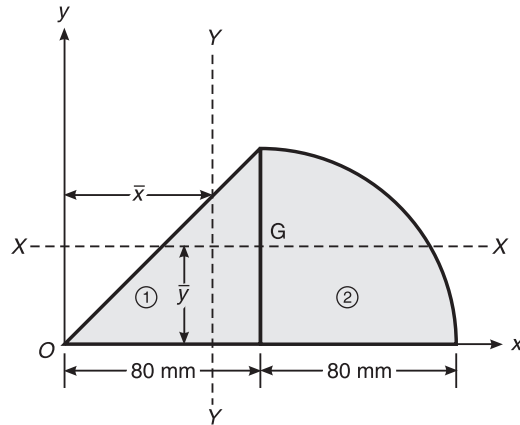

Figure 9.22 Example 9.6.

Solution

| Component | Area, a | x | y | ax | ay |
|------------------|---|--|--|-------------------------------|-------------------------------|
| Triangle 1 | $\frac{1}{2} \times 80 \times 80$ $= 3200$ | $\frac{2}{3} \times 80$ $= 53.33$ | $\frac{1}{3} \times 80$ $= 26.67$ | 170,665.6 | 85,334.4 |
| Quarter circle 2 | $\frac{\pi \times 80^2}{4}$ $= 5026.548$ | $80 + \frac{4 \times 80}{3 \times \pi}$ $= 113.953$ | $\frac{4 \times 80}{3 \times \pi}$ $= 33.953$ | 572,790.224 | 170,666.384 |
| Sum | Σa $= 8226.548$ | | | Σax $= 743,455.82$ | Σay $= 256,000.78$ |

$$\bar{x} = \frac{\Sigma ax}{\Sigma a} = \frac{743,455.824}{8226.548} = 90.373 \text{ mm}; \quad \bar{y} = \frac{\Sigma ay}{a} = \frac{256,000.784}{8226.548} = 31.119 \text{ mm} \quad \text{Ans.}$$

Example 9.7 Calculate the centroid of Figure 9.23.

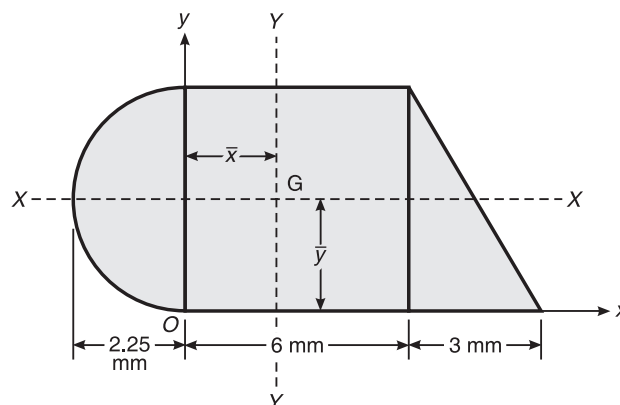

Figure 9.23 Example 9.7.

230 ELEMENTS OF CIVIL ENGINEERING AND ENGINEERING MECHANICS

| Component | Area, a | x | y | ax | ay |
|------------|--|--|--------------------------------|-------------------------|-------------------------|
| Rectangle | $6 \times 4.5 = 27$ | $\frac{6}{2} = 3$ | $\frac{4.5}{2} = 2.25$ | 81 | 60.75 |
| Triangle | $\frac{1}{2} \times 3 \times 4.5 = 6.75$ | $6 + \frac{1}{3} \times 3 = 7$ | $\frac{1}{3} \times 4.5 = 1.5$ | 47.25 | 101.25 |
| Semicircle | $\frac{\pi \times (2.25)^2}{2} = 7.95$ | $\frac{-4 \times 2.25}{3 \times \pi} = -0.955$ | $\frac{4.5}{2} = 2.25$ | -7.594 | 17.892 |
| Sum | Σa = 41.702 | | | Σax = 120.65 | Σay = 88.767 |

$$\bar{x} = \frac{\Sigma ax}{\Sigma a} = \frac{120.656}{41.702} = 2.893 \text{ mm}; \quad \bar{y} = \frac{\Sigma ay}{\Sigma a} = \frac{88.767}{41.702} = 2.129 \text{ mm} \quad \text{Ans.}$$

Example 9.8 Determine the centroid of the shaded area shown in Figure 9.24.

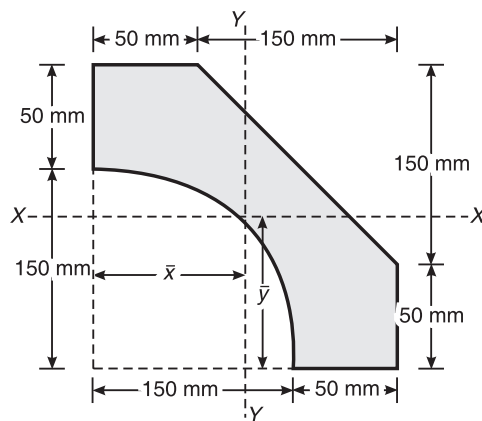

Figure 9.24 Example 9.8.

Solution

| Component | Area, a | x | y | ax | ay |
|----------------|---|---|---|-------------------------------|-------------------------------|
| Rectangle | $200 \times 200 = 40,000$ | $\frac{200}{2} = 100$ | $\frac{200}{2} = 100$ | 4,000,000.00 | 4,000,000.00 |
| Quarter circle | $\frac{\pi \times (150)^2}{4}$ = -17,671.459 | $\frac{4 \times 150}{3 \times \pi}$ = 63.662 | $\frac{4 \times 150}{3 \times \pi}$ = 63.662 | -1,125,000.00 | -397,60.78 |
| Triangle | $\frac{1}{2} \times 150 \times 50$ = -3750 | $\frac{2}{3} \times 150 + 50$ = 150 | $50 + \frac{2}{3} \times 150$ = 150 | -562,500.00 | -5625.00 |
| Sum | Σa = 18,578.54 | | | Σax = 2,312,500.00 | Σay = 3,954,614.22 |

$$\bar{x} = \frac{\Sigma ax}{\Sigma a} = \frac{2,312,500}{18,578.54} = 124.47 \text{ mm}$$

$$\bar{y} = \frac{3,954,614.22}{18,578.54} = 212.86 \text{ mm}$$

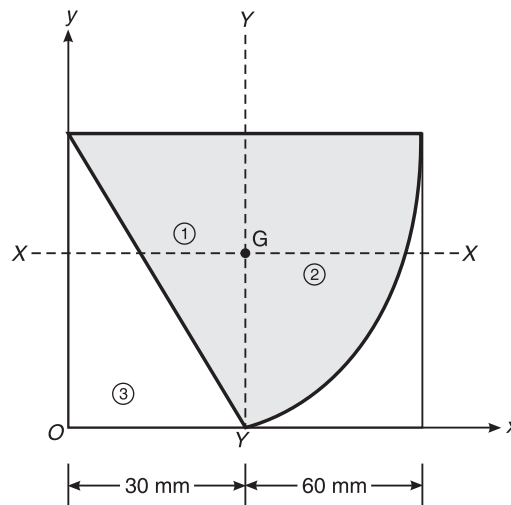
Ans.**Example 9.9** Determine the centroid of the shaded area shown in Figure 9.25.**Figure 9.25** Example 9.9.**Solution**

| Component | Area, a | x | y | ax | ay |
|-------------|--|---|---|-------------|-------------|
| Rectangle 1 | $30 \times 60 = 1800$ | 15 | 30 | 27,000 | 54,000 |
| Quadrant 2 | $\frac{\pi \times (60)^2}{4}$ $= 2827.43$ | $\frac{4 \times 60}{3\pi} + 30$ $= 55.465$ | $60 - \frac{4 \times 60}{3\pi}$ $= 34.535$ | 156,823.571 | 97,645.399 |
| Triangle 3 | $-\frac{1}{2} \times 30 \times 60$ $= -900$ | $\frac{1}{3} \times 30$ $= 10$ | $\frac{1}{3} \times 60$ $= 20$ | -9000 | -18,000 |
| Sum | $\Sigma a = 3727.433$ | | | 174,823.571 | 133,645.399 |

$$\bar{x} = \frac{\Sigma ax}{\Sigma a} = \frac{174,823.571}{3727.433} = 46.901 \text{ mm}$$

$$\bar{y} = \frac{\Sigma ay}{\Sigma a} = \frac{133,645.399}{3727.433} = 35.854 \text{ mm}$$

Ans.

232 ELEMENTS OF CIVIL ENGINEERING AND ENGINEERING MECHANICS

Example 9.10 Locate the centre of the shaded area shown in Figure 9.26.

VTU (August 2005)

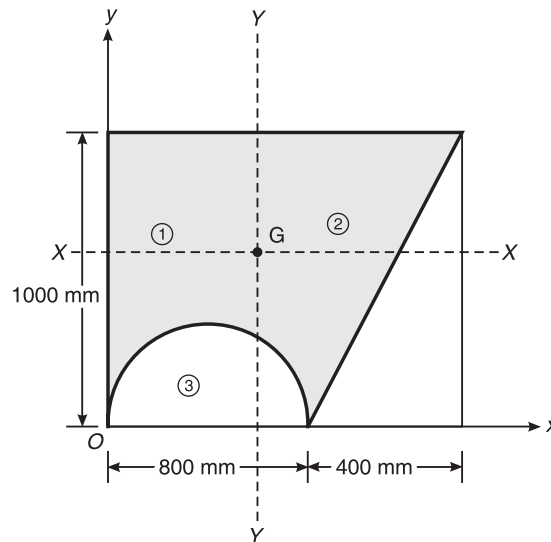
**Figure 9.26** Example 9.10.**Solution**

| Component | Area, a | x | y | ax | ay |
|------------|---|--|--|-----------------|-----------------|
| Rectangle | 1200×100 $= 1,200,000$ | $\frac{1200}{2} = 600$ | $\frac{1000}{2} = 500$ | 720,000,000 | 600,000,000 |
| Triangle | $-\frac{1}{2} \times 400 \times 1000$ $= -200,000$ | $800 + \frac{2}{3} \times 400$ $= 1066.667$ | $\frac{1}{3} \times 1000$ $= 333.333$ | -100,530,964.8 | -42,666,518.1 |
| Semicircle | $-\frac{\pi r^2}{4}$ $= -251,327.41$ | $\frac{800}{2} = 400$ | $\frac{4r}{3\pi} = 169.765$ | -213,333,333.33 | -66,666,666.667 |
| Sum | $\Sigma a = 748,672.59$ | | | 406,135,701.75 | 490,666,666.67 |

$$\bar{x} = \frac{\Sigma ax}{\Sigma a} = \frac{406,135,701.75}{748,672.59} = 542.474 \text{ mm}$$

$$\bar{y} = \frac{\Sigma ay}{\Sigma a} = \frac{490,666,666.67}{748,672.59} = 655.382 \text{ mm}$$

Ans.

Example 9.11 Determine the centroid of Figure 9.27.

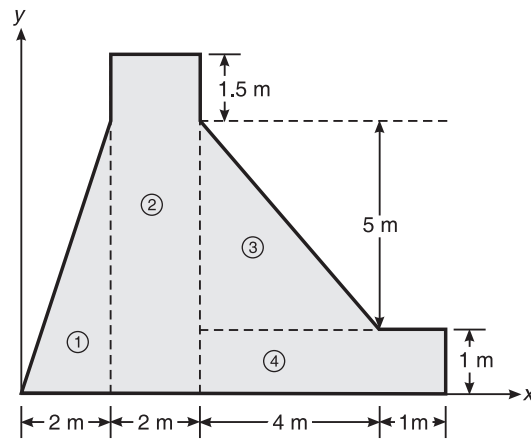

Figure 9.27 Example 9.11.

Solution

| Component | Area, a | x | y | ax | ay |
|-------------|--------------------------------------|-----------------------------------|-----------------------------------|----------------------|---------------------|
| Triangle 1 | $\frac{1}{2} \times 6 \times 2 = 6$ | $\frac{2}{3} \times 2 = 1.33$ | $\frac{1}{3} \times 6 = 2$ | 7.98 | 12 |
| Rectangle 2 | $2 \times 7.5 = 15$ | $\frac{2}{2} + 2 = 3$ | $\frac{7.5}{2} = 3.75$ | 45 | 56.25 |
| Triangle 3 | $\frac{1}{2} \times 4 \times 5 = 10$ | $4 + \frac{1}{3} \times 4 = 5.33$ | $1 + \frac{1}{3} \times 5 = 2.67$ | 53.33 | 26.67 |
| Rectangle 4 | $5 \times 1 = 5$ | $\frac{5}{2} + 4 = 6.5$ | $\frac{1}{2} = 0.5$ | 32.5 | 2.5 |
| Sum | $\Sigma a = 36$ | | | $\Sigma ax = 138.81$ | $\Sigma ay = 97.42$ |

$$\bar{x} = \frac{\Sigma ax}{\Sigma a} = \frac{138.81}{36} = 3.856 \text{ m}$$

$$\bar{y} = \frac{\Sigma ay}{\Sigma a} = \frac{97.42}{36} = 2.706 \text{ m}$$

Ans.

234 ELEMENTS OF CIVIL ENGINEERING AND ENGINEERING MECHANICS

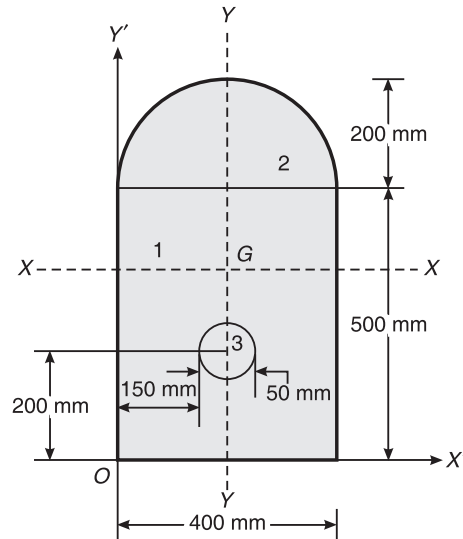
Example 9.12 Determine the centroid of Figure 9.28.**Figure 9.28** Example 9.12.**Solution**

| Component | Area, a | x | y | ax | ay |
|--------------|--|---------------------------------|---|---------------------------------|----------------------------------|
| Rectangle 1 | 400×500 $= 200,000$ | $\frac{400}{2} = 200$ | $\frac{500}{2} = 250$ | 40,000,000 | 50,000,000 |
| Semicircle 2 | $\frac{\pi \times (200)^2}{2}$ $= 62,831.853$ | $\frac{400}{2} = 200$ | $500 + \frac{4 \times 200}{3\pi}$ $= 84.883$ | 12,566,370.6 | 36,749,282.68 |
| Circle 3 | $\pi \times (25)^2$ $= -1963.495$ | $150 + \frac{50}{2}$ $= 175$ | 200 | -343,611.696 | -392,699 |
| Sum | Σa $= 260,868.358$ | | | Σax $= 52,222,758.9$ | Σay $= 86,356,583.68$ |

$$\bar{x} = \frac{\Sigma ax}{\Sigma a} = \frac{52,222,758.9}{260,868.358} = 200.188 \text{ mm}$$

$$\bar{y} = \frac{\Sigma ay}{\Sigma a} = \frac{86,356,583.68}{260,868.358} = 331.035 \text{ mm}$$

Ans.

Example 9.13 Locate the centroid of the shaded area shown in Figure 9.29.

VTU (February 2005)

The given figure is symmetrical about the Y - Y axis and hence $\bar{x} = 0$.

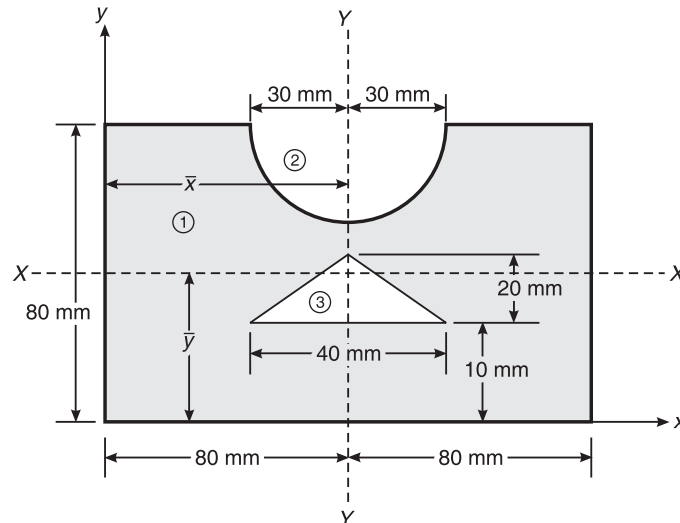

Figure 9.29 Example 9.13.

Solution

| Component | Area, a (mm^2) | y | ay |
|--------------|--|---|--------------------------|
| Rectangle 1 | $160 \times 80 = 12,800$ | $\frac{80}{2} = 40$ | 512,000 |
| Semicircle 2 | $\pi \times (30)^2$ $= -1413.716$ | $80 - \frac{4 \times 30}{3\pi}$ $= 67.268$ | -95,097.848 |
| Triangle 3 | $-\frac{1}{2} \times 40 \times 20$ $= -400$ | $10 + \frac{1}{3} \times 20$ $= 16.667$ | -6666.8 |
| Sum | $\Sigma a = 10,986.284$ | | $\Sigma ay = 410,235.35$ |

$$\bar{y} = \frac{\Sigma ay}{\Sigma a} = \frac{410,235.352}{10,986.284} = 37.341 \text{ mm}$$

Ans.

236 ELEMENTS OF CIVIL ENGINEERING AND ENGINEERING MECHANICS

Example 9.14 Locate the centroid of the shaded area shown in Figure 9.30.

VTU (August 2004)

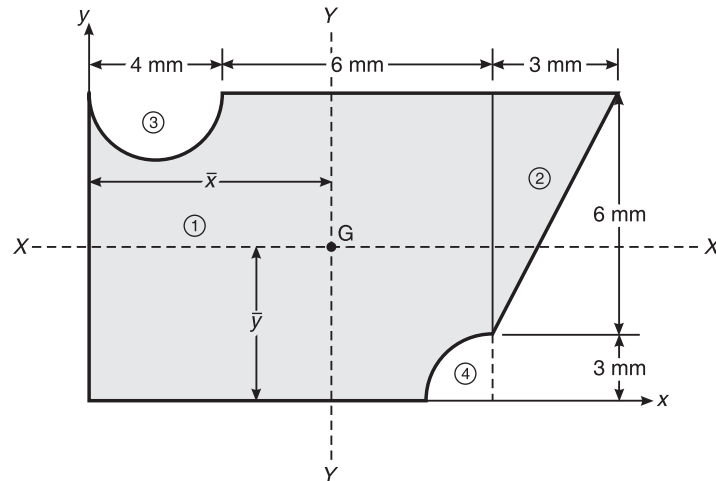
**Figure 9.30** Example 9.14.**Solution**

| Component | Area, a | x | y | ax | ay |
|--------------|--|---|--|----------------------------|----------------------------|
| Rectangle 1 | $10 \times 9 = 90$ | $\frac{10}{2} = 5$ | $\frac{9}{2} = 4.5$ | 450 | 405 |
| Triangle 2 | $\frac{1}{2} \times 3 \times 6 = 9$ | $10 + \frac{1}{3} \times 3 = 11$ | $3 + \frac{2}{3} \times 6 = 7$ | 99 | 63 |
| Semicircle 3 | $\frac{\pi \times (2)^2}{2}$ $= -6.283$ | $\frac{4}{2} = 2$ | $9 - \frac{4 \times 2}{3\pi}$ $= 8.151$ | -12.566 | -51.213 |
| Quadrant 4 | $\frac{\pi(3)^2}{4}$ $= -7.068$ | $10 - \frac{4 \times 3}{3\pi}$ $= 8.727$ | $\frac{4 \times 3}{3 \times \pi}$ $= 1.273$ | -61.682 | -8.998 |
| Sum | Σa $= 85.649$ | | | Σax $= 474.752$ | Σay $= 407.789$ |

$$\bar{x} = \frac{\Sigma ax}{\Sigma a} = 5.543 \text{ mm}$$

$$\bar{y} = \frac{\Sigma ay}{\Sigma a} = 4.761 \text{ mm}$$

Ans.

Example 9.15 Determine the centroid of Figure 9.31.

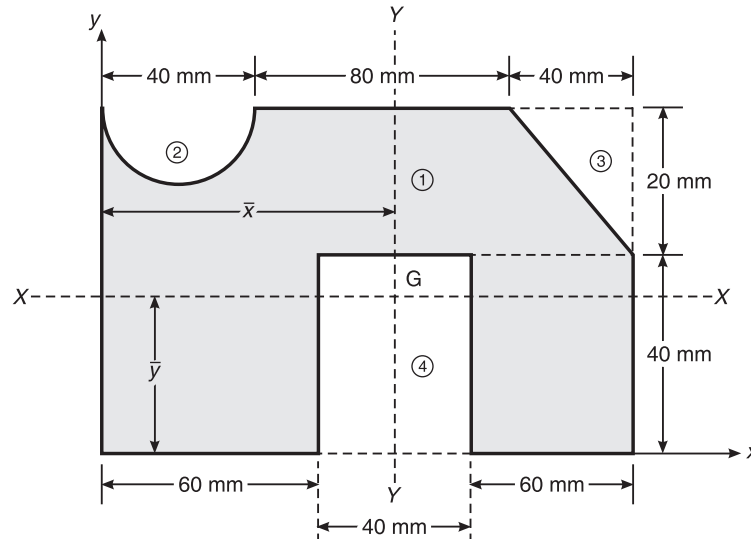

Figure 9.31 Example 9.15.

Solution

| Component | Area, a | x | y | ax | ay |
|--------------|--|--|--|-------------------------------|--------------------------------|
| Rectangle 1 | $160 \times 60 = 9600$ | $\frac{160}{2} = 80$ | $\frac{60}{2} = 30$ | 768,000 | 288,000 |
| Semicircle 2 | $-\frac{\pi \times (20)^2}{2}$ $= -628.319$ | $\frac{40}{2} = 20$ | $60 - \frac{4 \times 20}{3 \times \pi}$ | -12,566.38 | -32,365.968 |
| Triangle 3 | $-\frac{1}{2} \times 40 \times 20$ $= -400$ | $120 + \frac{2}{3} \times 40$ $= 146.667$ | $40 + \frac{2}{3} \times 20$ $= 53.333$ | -58,666.8 | -21,333.2 |
| Rectangle 4 | $-40 \times 40 = -1600$ | $60 + \frac{40}{2} = 80$ | $\frac{40}{2} = 20$ | -128,000 | -32,000 |
| Sum | Σa $= 6971.681$ | | | Σax $= 568,766.82$ | Σay $= 202,300.832$ |

$$\bar{x} = \frac{\Sigma ax}{\Sigma a} = \frac{568,766.96}{6971.68} = 81.58 \text{ mm}$$

$$\bar{y} = \frac{\Sigma ay}{\Sigma a} = \frac{202,300.89}{6971.68} = 29.02 \text{ mm}$$

Ans.

Example 9.16 Determine the position of the centroid for the lamina with a circular cut-out shown in Figure 9.32.

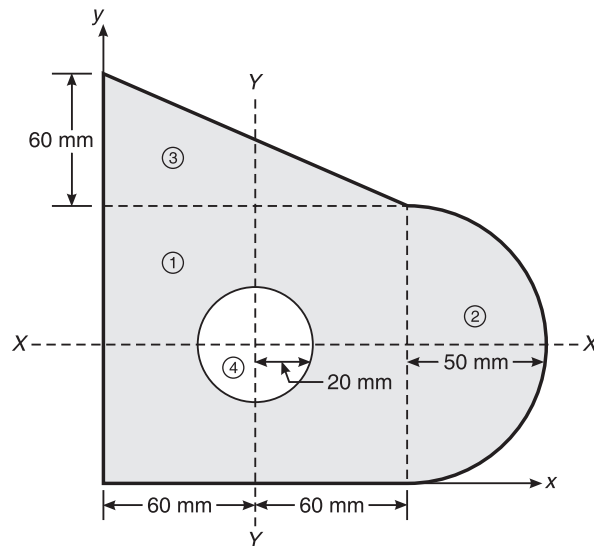

Figure 9.32 Example 9.16.

Solution

| Component | Area, a | x | y | ax | ay |
|--------------|---|--|--|--------------------------------|------------------------------|
| Rectangle 1 | 120×100 $= 12,000$ | $\frac{120}{2} = 60$ | $\frac{100}{2} = 50$ | 720,000 | 600,000 |
| Triangle 3 | $120 \times 60 \times \left(\frac{1}{2}\right)$ $= 3600$ | $\frac{1}{3} \times 120$ $= 40$ | $100 + \frac{1}{3} \times 60$ $= 120$ | 144,000 | 432,000 |
| Semicircle 2 | $\frac{\pi \times (50)^2}{2}$ $= 3926.991$ | $120 + \frac{4 \times 50}{3\pi}$ $= 141.22$ | $\frac{100}{2} = 50$ | 554,573.6 | 196,349.6 |
| Circle 4 | $-\pi \times (20)^2$ $= -1256.637$ | 60 | $\frac{100}{2} = 50$ | -75,398.22 | -62,831.9 |
| Sum | Σa $= 182,70.354$ | | | Σax $= 1,343,175.4$ | Σay $= 1,165,517$ |

$$\bar{x} = \frac{\Sigma ax}{\Sigma a} = \frac{1,343,175.376}{18,270.354} = 73.517 \text{ mm}$$

$$\bar{y} = \frac{\Sigma ay}{\Sigma a} = \frac{1,165,517.7}{18,270.354} = 63.793 \text{ mm}$$

Ans.

Example 9.17 Determine the centroid of the shaded area shown in Figure 9.33.

VTU (August 2005)

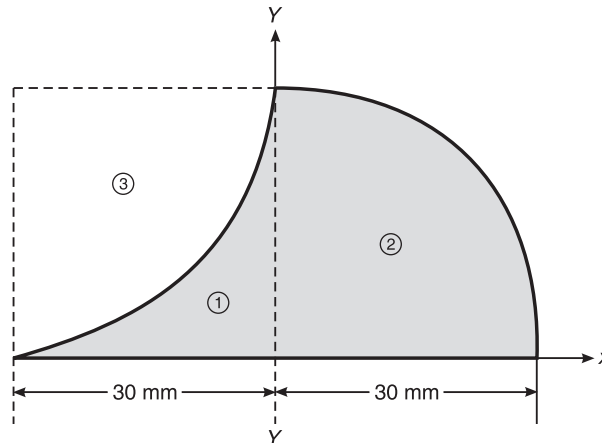

Figure 9.33 Example 9.17.

Solution In the above figure, the centroidal axis is not coinciding with the reference y-axis as the figure is not symmetrical about y-axis.

| Component | Area, a | x | y | ax | ay |
|-------------|--|---|---|--------------------------|-----------------------------|
| Rectangle 1 | $30 \times 30 = 900$ | $-\frac{30}{2} = -15$ | $\frac{30}{2} = 15$ | -13,500 | 13,500 |
| Quadrant 2 | $\frac{\pi \times (30)^2}{4}$ = 706.858 | $\frac{4 \times 30}{3\pi}$ = 12.732 | $\frac{4 \times 10}{3\pi}$ = 12.732 | 8999.716 | 8999.716 |
| Quadrant 3 | $-\frac{\pi \times (30)^2}{4}$ = -706.858 | $-\left(30 - \frac{4 \times 30}{\pi}\right)$ = -17.268 | $\left(30 - \frac{4 \times 30}{\pi}\right)$ = 17.268 | -12,206.02 | 12,206.02 |
| Sum | Σa = 900 | | | Σax = 7705.74 | Σay = 10,291.692 |

$$\bar{x} = \frac{\Sigma ax}{\Sigma a} = \frac{7705.74}{900} = 8.56 \text{ mm}$$

$$\bar{y} = \frac{\Sigma ay}{\Sigma a} = \frac{10,291.692}{900} = 11.435 \text{ mm}$$

Ans.

240 ELEMENTS OF CIVIL ENGINEERING AND ENGINEERING MECHANICS

Example 9.18 Determine the coordinates x_c and y_c of the centre of a 100 mm diameter circular hole cut in a thin plate so that this point will be the centroid of the remaining shaded area shown in Figure 9.34.

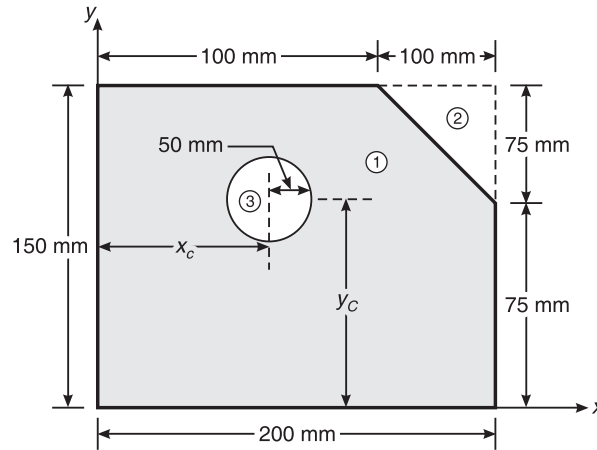

Figure 9.34 Example 9.18.

C.G. of the circular hole = C.G. of the shaded area

$$\bar{x} = \frac{a_1x_1 - a_2x_2 - a_3x_3}{a_1 - a_2 - a_3}$$

$$x_c = \frac{200 \times 150 \times 100 - \frac{1}{2} \times 100 \times 75 \times \left(100 + \frac{2}{3} \times 100\right) - \pi(50)^2 \times x_c}{200 \times 150 - \frac{1}{2} \times 100 \times 75 - \pi(50)^2}$$

$$= \frac{3,000,000 - 25,000 - 7853.982 x_c}{18,396.018}$$

or $18,396.018 x_c = 2,375,000 - 7853.982 x_c$

or $x_c = \frac{2,375,000}{26,250} = 90.476 \text{ mm}$

Ans.

$$\bar{y} = \frac{a_1y_1 - a_2y_2 - a_3y_3}{a_1 - a_2 - a_3}$$

$$y_c = \frac{200 \times 150 \times 75 - \frac{1}{2} \times 75 \times 100 \left(75 + \frac{2}{3} \times 75\right) - \pi(50)^2 \times y_c}{18,396.018}$$

or $y_c = \frac{2,250,000 - 468,750 - 7853.982 y_c}{18,396.018}$

$$\text{or} \quad 18,396.018 y_c = 1,781,250 - 7853.982 y_c$$

$$\text{or} \quad 26250 y_c = 1,781,250$$

$$\therefore y_c = \frac{1,781,250}{26,250} = 67857 \text{ mm}$$

Ans.

Example 9.19 Determine the centroid of the shaded area with reference to apex, as shown in Figure 9.35.

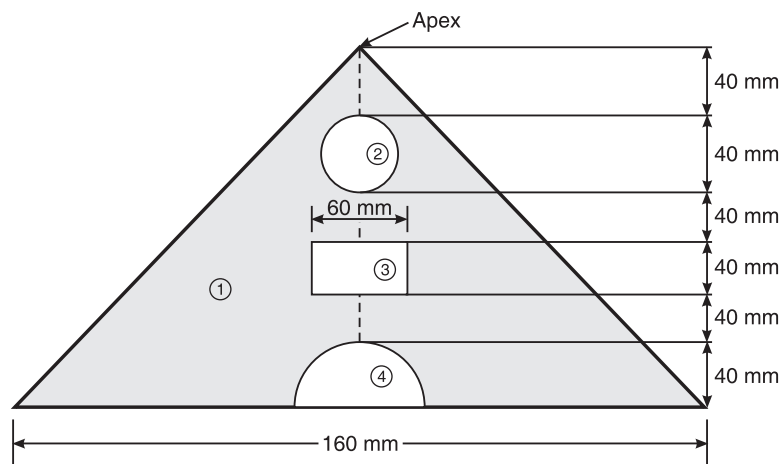

Figure 9.35 Example 9.19.

Solution

| Component | Area, a | Centroidal distance from apex, y | ay |
|--------------|--|--|---------------------------------|
| Triangle 1 | $\frac{1}{2} \times 160 \times 240 = 19,200$ | $\frac{2}{3} \times 240 = 160$ | 3.072×10^6 |
| Circle 2 | $-\pi(20)^2 = -1256.637$ | $\frac{20}{2} + 40 = 50$ | -62.831×10^3 |
| Rectangle 3 | $-60 \times 40 = -2400$ | $120 + \frac{40}{2} = 140$ | -3.36×10^5 |
| Semicircle 4 | $-\frac{\pi \times 40^2}{2} = -2514.285$ | $240 - \frac{4 \times 40}{3\pi} = 223.023$ | -5.605×10^5 |
| Sum | $\Sigma a = 13030.088$ | | $\Sigma ay = 2.113 \times 10^6$ |

$$\bar{y} = \frac{\Sigma ay}{\Sigma a} = \frac{2.113 \times 10^6}{13030.088} = 162.137 \text{ mm}$$

and

$$\bar{x} = 0$$

Ans.

242 ELEMENTS OF CIVIL ENGINEERING AND ENGINEERING MECHANICS

Example 9.20 Determine the position of the centroid of the area shown in Figure 9.36.

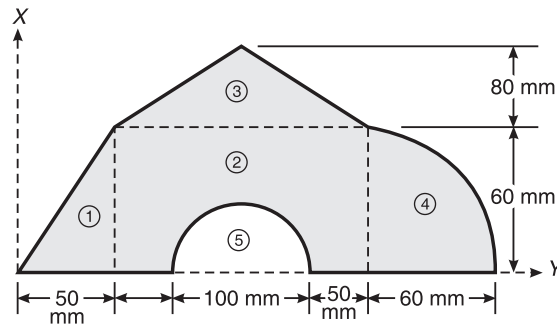

Figure 9.36 Example 9.20.

Solution

| Component | Area, a | x | y | ax | ay |
|------------------|--|---|--|----------------------------|-----------------------------|
| Triangle 1 | $\frac{1}{2} \times 50 \times 60$ = 1500 | $\frac{2}{3} \times 50$ = 33.333 | $\frac{1}{3} \times 60 = 20$ | 49,999.5 | 30,000 |
| Rectangle 2 | 200×60 = 12,000 | $\frac{200}{2} + 50$ = 150 | $\frac{60}{2} = 30$ | 1,800,000 | 360,000 |
| Triangle 3 | $\frac{1}{2} \times 200 \times 80$ = 8000 | $\frac{200}{2} + 50$ = 150 | $60 + \frac{80}{3}$ = 86.667 | 1,200,000 | 693,336 |
| Quarter circle 4 | $\frac{\pi \times 60^2}{4}$ = 2827.433 | $\frac{4 \times 60}{3\pi} + 250$ = 275.465 | $\frac{4 \times 60}{3\pi}$ = 25.465 | 778,858.831 | 72,000.581 |
| Semi circle 5 | $-\frac{\pi \times 50^2}{2}$ = -3926.991 | $\frac{100}{2} + 100$ = 150 | $\frac{4 \times 50}{3\pi}$ = 21.22 | -589,048.65 | -83,334.676 |
| Sum | $\Sigma a = 20,400.442$ | | | $\Sigma ax = 3,239,809.68$ | $\Sigma ay = 1,072,001.905$ |

$$\bar{x} = \frac{\Sigma ax}{\Sigma a} = \frac{3,239,809.681}{20,400.442} = 158.81 \text{ mm}$$

$$\bar{y} = \frac{\Sigma ay}{\Sigma a} = \frac{1,072,001.905}{20,400.442} = 52.548 \text{ mm}$$

Ans.

Example 9.21 Locate the centroid of the plane shown in Figure 9.37 with respect to O .

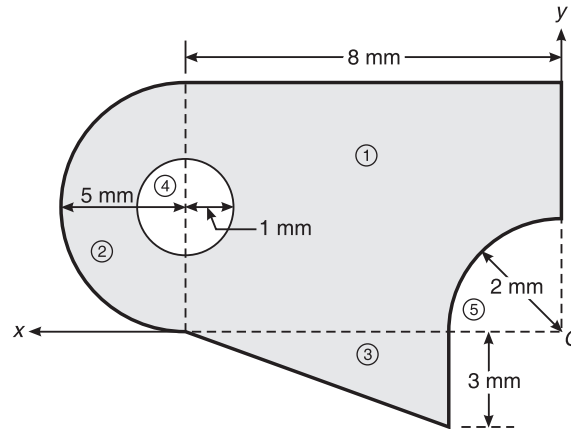

Figure 9.37 Example 9.21.

Solution

| Component | Area, a | x | y | ax | ay |
|------------------|---|--|--|-----------------------------|----------------------------|
| Rectangle 1 | $8 \times 10 = 80$ | $-\frac{8}{2} = -4$ | $\frac{10}{2} = 5$ | -320 | -400 |
| Semicircle 2 | $\frac{\pi \times 5^2}{2} = 39.269$ | $-\left(\frac{4 \times 5}{3\pi} + 8\right)$ | $\frac{10}{2} = 5$ | -397.483 | -196.345 |
| Triangle 3 | $\frac{1}{2} \times 6 \times 3 = 9$ | $-\left(\frac{1}{3} \times 6 + 2\right)$ | $-\left(\frac{1}{3} \times 3\right)$ | -36 | -9 |
| Circle 4 | $-\pi(1)^2 = -3.142$ | -8 | $\frac{10}{2} = 5$ | 25.136 | -15.71 |
| Quarter circle 5 | $-\frac{\pi \times 2^2}{4}$ $= -3.142$ | $-\left(\frac{4 \times 2}{3\pi}\right)$ $= 0.849$ | $\left(\frac{4 \times 2}{3\pi}\right)$ $= 0.84$ | 2.676 | -2.667 |
| Sum | Σa $= 121.985$ | | | Σax $= -725.671$ | Σay $= 568.968$ |

$$\bar{x} = \frac{\Sigma ax}{\Sigma a} = \frac{-725.671}{121.985} = -5.95 \text{ mm}$$

$$\bar{y} = \frac{\Sigma ay}{\Sigma a} = \frac{568.968}{121.985} = 4.67 \text{ mm}$$

Ans.

EXERCISE PROBLEMS

1. Determine the centroid of the lamina shown in Figure 9.38.

[Ans.: $\bar{x} = 50 \text{ mm}$ and $\bar{y} = 65.45 \text{ mm}$]

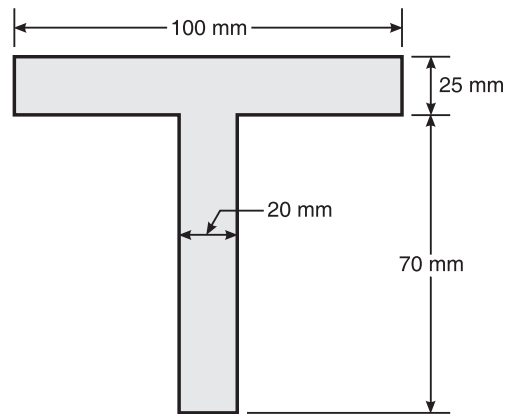

Figure 9.38

2. Determine the centroid of the area shown in Figure 9.39.

[Ans.: $\bar{x} = 214.4 \text{ mm}$ and $\bar{y} = 214.4 \text{ mm}$]

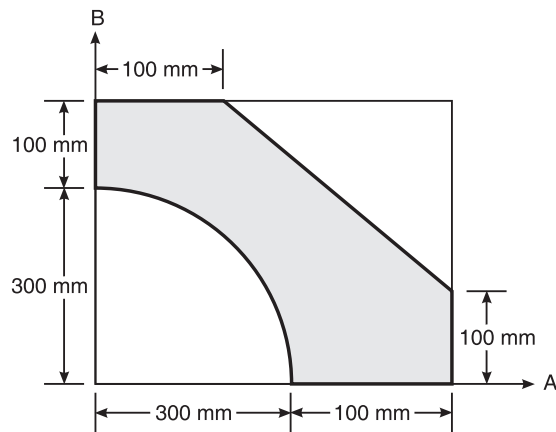

Figure 9.39

3. Locate the centroid of the lamina shown in Figure 9.40.

[Ans.: $\bar{x} = 69.77$ mm, $\bar{y} = 127.32$ mm]

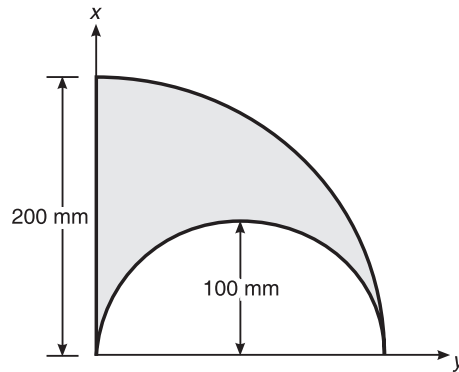

Figure 9.40

4. In Figure 9.41, determine the coordinates of the centre of 6 mm diameter circular hole cut in the plate, so that this point will be the centroid of the remaining shaded area

[Ans.: 10.86 mm, 8.14 mm]

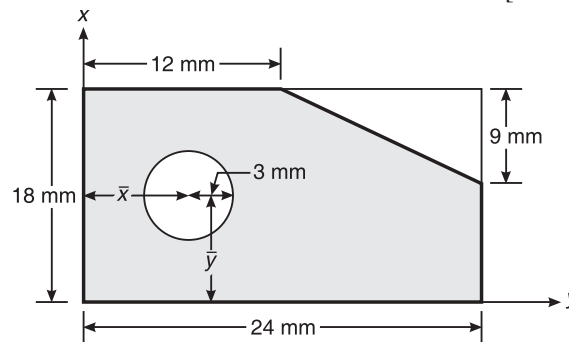

Figure 9.41

5. Find the centroid of Figure 9.42.

[Ans.: $\bar{x} = 300$ mm and $\bar{y} = -127.32$ mm]

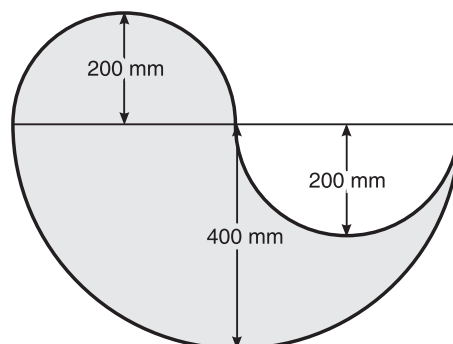

Figure 9.42

246 ELEMENTS OF CIVIL ENGINEERING AND ENGINEERING MECHANICS

6. Determine the centroid of Figure 9.43 for $a = 10$ mm.

[Ans.: $\bar{x} = 39.94$ mm and $\bar{y} = 31.46$ mm]

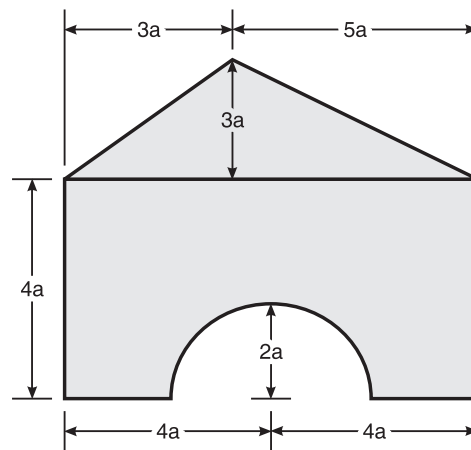

Figure 9.43

7. Find the centroid of the shaded area in Figure 9.44.

[Ans.: $\bar{x} = 40.14$ mm and $\bar{y} = 19.5$ mm]

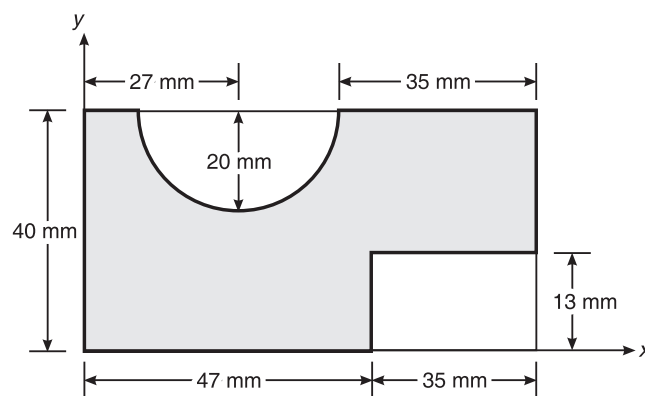

Figure 9.44

8. Determine the centroid of the lamina shown in Figure 9.45.

[Ans.: $\bar{x} = 73.52$ mm and $\bar{y} = 63.79$ mm]

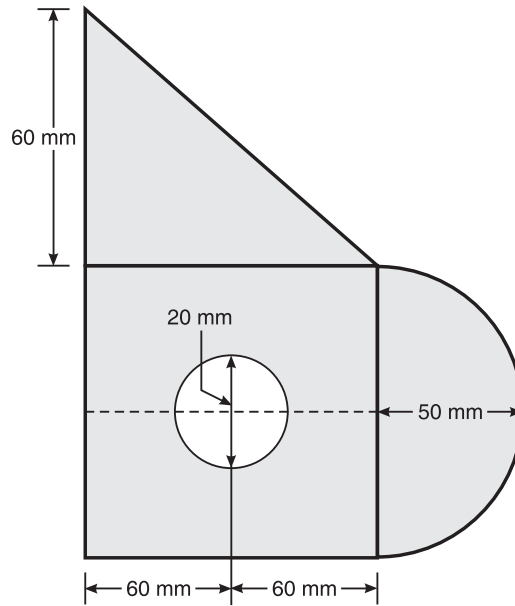

Figure 9.45

MOMENT OF INERTIA

INTRODUCTION

Let us consider an irregular plane lamina of area A , whose centre of gravity is at distance x from the reference Y -axis and at a distance y from reference X -axis (Figure 10.1).

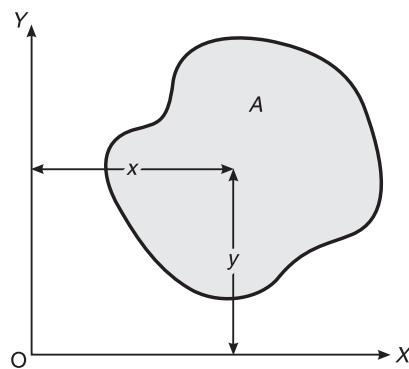

Figure 10.1 Irregular plane lamina.

Moment of area about the y -axis = first moment of area. If the first moment of area is multiplied by the perpendicular distance x , it gives Ax^2 known as the second moment of area or moment of inertia.

Moment of inertia about y-axis, $I_{yy} = Ax^2$

Moment of inertia about x-axis, $I_{xx} = Ay^2$

Least and greatest moment of inertia

\bar{I}_x and \bar{I}_y are the moment of inertia of a plane figure about x-axis and y-axis. If \bar{I}_x is greater than \bar{I}_y then \bar{I}_x is known as the **greatest moment of inertia** and \bar{I}_y is called the **least moment of inertia**.

The unit of moment of inertia is mm^4 or m^4 .

Radius of gyration (k)

It is the distance from the given axis where the whole area of a plane figure is assumed to be concentrated so as not to alter the moment of inertia about the given axis. For example, the moment of inertia about axis 1-1 (Figure 10.2) is

$$I = Ak^2$$

and hence

$$k = \sqrt{\frac{I}{A}}$$

That is,

$$k_x = \sqrt{\frac{\bar{I}_x}{A}} \quad \text{and} \quad k_y = \sqrt{\frac{\bar{I}_y}{A}}$$

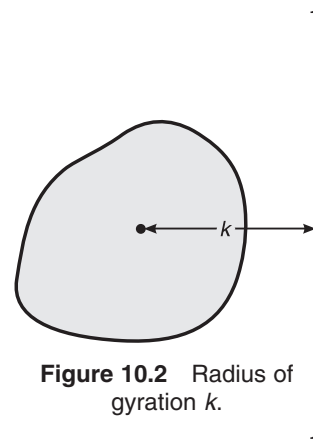

Figure 10.2 Radius of gyration k .

PARALLEL AXIS THEOREM

This theorem states that the moment of inertia of plane figure about an axis I_{1-1} , parallel to the centroidal axis, \bar{I}_x is equal to sum of moment of inertia about centroidal axis, i.e. \bar{I}_x and the product of area of the plane figure and square of the distance between the two axes.

Proof: Let us consider a plane figure of total area A as shown in Figure 10.3. Let \bar{I}_x be the moment of inertia about the x -axis and I_{1-1} the moment of inertia about 1-1 axis.

Let us choose an elemental strip of area da at a distance y from the centroidal axis.

Moment of inertia of the strip about x - x axis = $da \cdot y^2$

Moment of inertia of the total area about the x - x axis = $\bar{I}_x = \Sigma da \cdot y^2$

Moment of inertia of the strip about 1-1 axis = $da(y + \bar{y})^2$

Moment of inertia of the total area about 1-1 axis

$$I_{1-1} = \Sigma da(y^2 + \bar{y}^2 + 2y\bar{y})$$

$$I_{1-1} = \Sigma day^2 + \Sigma da \bar{y}^2 + 2\bar{y}(\Sigma day)$$

As the distance of C.G. of whole area from the centroidal axis = 0, i.e. $y = 0$, we get

$$I_{1-1} = \bar{I}_x + A \bar{y}^2$$

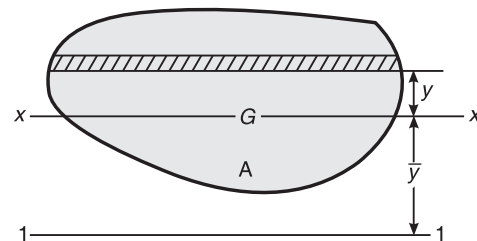

Figure 10.3 Illustration of parallel axis theorem for moment of inertia about an axis parallel to x - x axis.

250 ELEMENTS OF CIVIL ENGINEERING AND ENGINEERING MECHANICS

Similarly the moment of inertia about an axis I_{2-2} as shown in Figure 10.4 is given by

$$I_{2-2} = \bar{I}_y + A\bar{x}^2$$

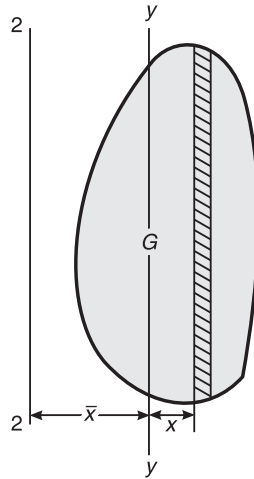

Figure 10.4 Illustration of parallel axis theorem for moment of inertia about an axis parallel to y - y axis.

PERPENDICULAR AXIS THEOREM

This theorem states that the moment of inertia of a plane figure about an axis which is perpendicular to the plane of the figure is equal to sum of moment of inertia about two mutually perpendicular axes.

Proof: Let us consider an irregular figure of total area A as shown in Figure 10.5. Let us choose an elemental strip of area da at a distance x from y -axis, y from x -axis and r from z -axis, respectively. Then,

$$r^2 = x^2 + y^2$$

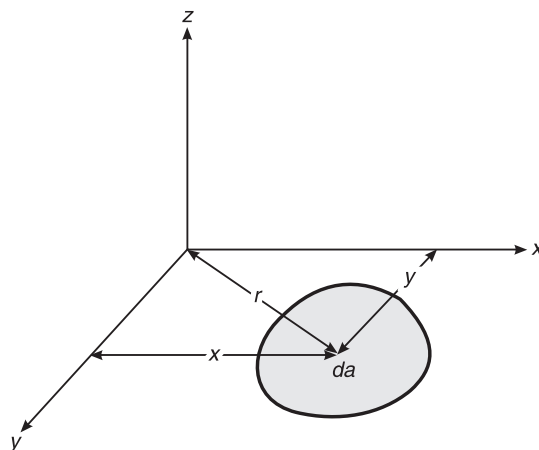

Figure 10.5 Illustration of perpendicular axis theorem.

Moment of inertia of the strip about x -axis = $da \times y^2$

Moment of inertia of the whole area about the x -axis = $\bar{I}_x = \Sigma da \cdot y^2$

Similarly, moment of inertia of the strip about y -axis = $da \times x^2$

Moment of inertia of the whole area about y -axis = $\bar{I}_y = \Sigma da \cdot x^2$

Moment of inertia of the strip about z -axis = $da \times r^2$

Moment of inertia of the whole area about z -axis = $\Sigma da \cdot r^2$

$$= \Sigma da(x^2 + y^2)$$

$$= \Sigma da \cdot x^2 + \Sigma da \cdot y^2$$

$$= \bar{I}_y + \bar{I}_x$$

That is,

$$\bar{I}_z = \bar{I}_x + \bar{I}_y$$

MOMENT OF INERTIA OF IMPORTANT FIGURES

Rectangle

Let us consider a rectangular lamina of breadth b and depth d whose moment of inertia is to be determined (Figure 10.6). Now consider an elementary strip of area $b \cdot dy$ at a distance y from the centroidal x - x axis. The moment of inertia of the strip about the x - x axis = $b \cdot dy \times y^2$.

Moment of inertia of the whole figure about the x - x axis

$$= \int_{-d/2}^{d/2} b \cdot dy \times y^2$$

$$= b \left[\frac{y^3}{3} \right]_{-d/2}^{d/2}$$

$$= b \left[\frac{d^3}{24} + \frac{d^3}{24} \right]$$

$$= \frac{b \times d^3}{12}$$

That is,

$$\bar{I}_x = \frac{bd^3}{12}$$

Similarly,

$$\bar{I}_y = \frac{db^3}{12}$$

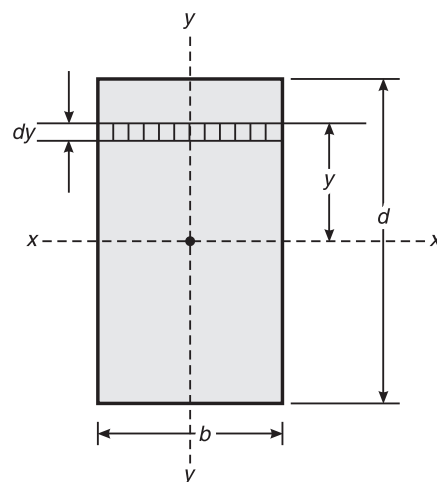

Figure 10.6 Rectangular lamina.

Triangle

Let us consider a triangular lamina of base b and depth d as shown in Figure 10.7. Let us consider an elementary strip of area $b_1 \times dy$ which is at a distance y from base AB.

Using the property of similar triangles,

$$\frac{b_1}{b} = \frac{d - y}{d}$$

or

$$b_1 = \frac{(d - y)b}{d}$$

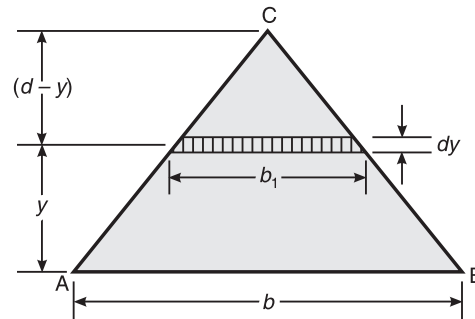

Figure 10.7 Triangular lamina.

$$\text{Area of the strip} = \frac{(d-y)b}{d} \cdot dy$$

$$\begin{aligned} \text{Moment of inertia of the strip about AB} &= \frac{(d-y)b}{d} dy \times y^2 \\ &= \frac{bdy^2 \cdot dy}{d} - \frac{by^3 \cdot dy}{d} \\ &= by^2 \cdot dy - \frac{by^3 \cdot dy}{d} \end{aligned}$$

Moment of inertia of the whole area about AB,

$$\begin{aligned} I_{AB} &= \int_0^d by^2 dy - \int_0^d \frac{b}{d} y^3 dy \\ &= b \left[\frac{y^3}{3} \right]_0^d - \frac{b}{d} \left[\frac{y^4}{4} \right]_0^d \\ &= \frac{bd^3}{3} - \frac{b}{d} \frac{d^4}{4} \\ &= \frac{bd^3}{3} - \frac{bd^3}{4} \end{aligned}$$

$$\therefore I_{AB} = \frac{bd^3}{12}$$

Moment of inertia about $x-x$ axis is given by

$$I_{AB} = \bar{I}_x + Ay^2$$

i.e.

$$\begin{aligned} \bar{I}_x &= I_{AB} - Ay^2 \\ &= \frac{bd^3}{12} - \frac{1}{2}bd \left(\frac{1}{3}d \right)^2 = \frac{bd^3}{36} \end{aligned}$$

Therefore, the moment of inertia of the triangle about the centroidal y -axis = $\frac{db^3}{36}$.

Circle

Derive an expression of moment of inertia of a circle about its diametrical axis.

Let us consider a circular lamina of radius R as shown in Figure 10.8.

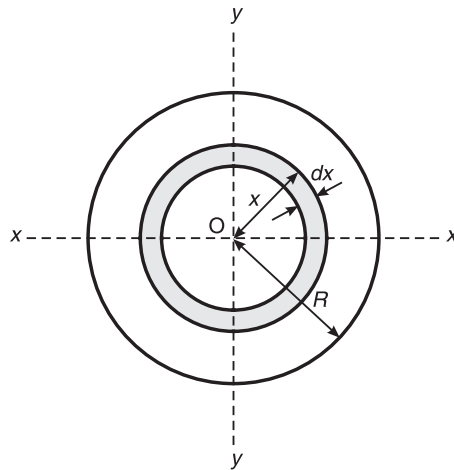

Figure 10.8 Circular lamina.

Let us choose a circular elementary strip of thickness dx at distance x from the centre.

Area of the strip $= 2\pi x dx$.

Moment of inertia about the z - z axis $= 2\pi x \cdot dx \cdot x^2$

Moment of inertia about the z - z axis for whole circle

$$\begin{aligned} \bar{I}_z &= \int_0^R 2\pi x^3 \cdot dx = 2\pi \left[\frac{x^4}{4} \right]_0^R \\ &= \frac{2\pi R^4}{4} = \frac{\pi R^4}{2} \end{aligned}$$

For the circular lamina,

$$\bar{I}_x = \bar{I}_y,$$

\therefore Using the perpendicular axis theorem, we have

$$\bar{I}_z = \bar{I}_x + \bar{I}_y$$

or

$$\bar{I}_z = 2\bar{I}_x$$

or

$$\bar{I}_x = \frac{\bar{I}_z}{2}$$

\therefore

$$\bar{I}_x = \frac{\pi R^4}{2 \times 2} = \frac{\pi R^4}{4} = \bar{I}_y$$

Semicircle

Let us consider a semicircular lamina of radius R as shown in Figure 10.9.

$$\text{Moment of inertia of semicircle about the diametrical axis AB} = \frac{1}{2} \times \frac{\pi R^4}{4} = \frac{\pi R^4}{8}$$

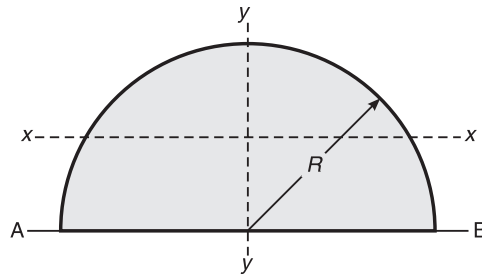

Figure 10.9 Semicircular lamina.

$$I_{AB} = \bar{I}_x + A \bar{y}^2$$

or

$$\begin{aligned} \bar{I}_x &= I_{AB} - \frac{\pi R^2}{2} \left(\frac{4R}{3\pi} \right)^2 \\ &= \frac{\pi R^4}{8} - \frac{\pi R^2 \times 16R^2}{2 \times 9\pi^2} \\ &= \frac{\pi R^4}{8} - \frac{8\pi R^4}{9\pi^2} \\ &= \frac{\pi R^4}{8} - \frac{8R^4}{9\pi} \end{aligned}$$

$$\therefore \bar{I}_x = 0.11R^4$$

Moment of inertia about the y-axis,

$$\bar{I}_y = \frac{\pi R^4}{8} = \frac{1}{2} \times \frac{\pi R^4}{4}$$

Quarter Circle

For a quarter circle of radius R as shown in Figure 10.10,

$$\bar{I}_x = \bar{I}_y = \frac{0.11R^4}{2} = 0.055R^4$$

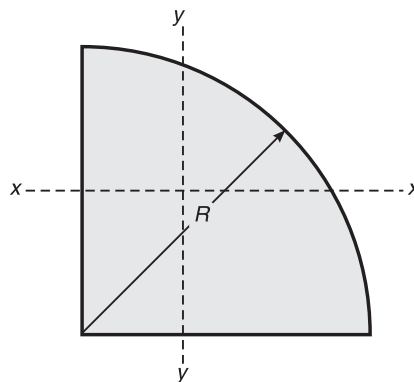

Figure 10.10 Quarter circle.

PROBLEMS ON MOMENT OF INERTIA

Steps to Solve Any Given Problem

1. Identify the reference axes. If the moment of inertia of the given figure is to be computed about any given axis, then select that axis itself as the reference axis. In general, select the symmetrical axis as the reference axis. If the figure is unsymmetrical, select the left bottom corner of the figure as the origin.
2. Subdivide the compound figure into known geometric shapes and identify the centroids of the sub-figures.
3. Write the tabular format as follows and enter the values.

Reference table

| Comp. | Area(A) | x | y | Ax | Ay | Ax ² | Ay ² | \bar{I}_x | \bar{I}_y |
|-------|------------|---|---|-------------|-------------|-----------------|-----------------|-----------------|-----------------|
| 1 | 2 | 3 | 4 | 5 | 6 | 7 | 8 | 9 | 10 |
| | ΣA | | | ΣAx | ΣAy | ΣAx^2 | ΣAy^2 | ΣI_{gx} | ΣI_{gy} |

where

Col. 1 indicates the component or sub-figure number

Col. 2 indicates the area of the sub-figure number

Col. 3 indicates the centroidal distance of the sub-figure from the y -reference axis

Col. 4 indicates the centroidal distance of the sub-figure from the x -reference axis

Col. 5 indicates the product of cells of Col. 2 and Col. 3

Col. 6 indicates the product of cells of Col. 2 and Col. 4

Col. 7 indicates the product of cells of Col. 3 and Col. 5

Col. 8 indicates the product of cells of Col. 4 and Col. 6

Col. 9 indicates the moment of inertia of the sub-figure about its individual centroidal x -axis

Col. 10 indicates the moment of inertia of the sub-figure about its individual centroidal y -axis

4. Compute the centroidal values of the given figure as

$$\bar{x} = \frac{\Sigma Ax}{\Sigma A} \quad \text{and} \quad \bar{y} = \frac{\Sigma Ay}{\Sigma A}$$

5. Compute the moment of inertia of the given compound figure on the x -reference axis using the parallel axis theorem, i.e.

$$I_{1-1} = \bar{I}_x + A \bar{y}^2$$

or

$$I_{1-1} = \Sigma \bar{I}_x + \Sigma Ay^2$$

6. Compute the moment of inertia of the given compound figure about its centroidal x -axis as

$$\bar{I}_x = I_{1-1} - A \bar{y}^2$$

7. Compute the moment of inertia of the given compound figure on the y -reference axis using the parallel axis theorem

$$I_{2-2} = \bar{I}_y + A \bar{x}^2$$

$$I_{2-2} = \Sigma \bar{I}_y + \Sigma Ax^2$$

256 ELEMENTS OF CIVIL ENGINEERING AND ENGINEERING MECHANICS

8. Compute the moment of inertia of the given compound figure about its centroidal
- y
- axis as

$$\bar{I}_y = I_{2-2} - A\bar{x}^2$$

Example 10.1 Find the moment of inertia along the horizontal axis and vertical axis passing through the centroid of a section shown in Figure 10.11. VTU (April 2001)

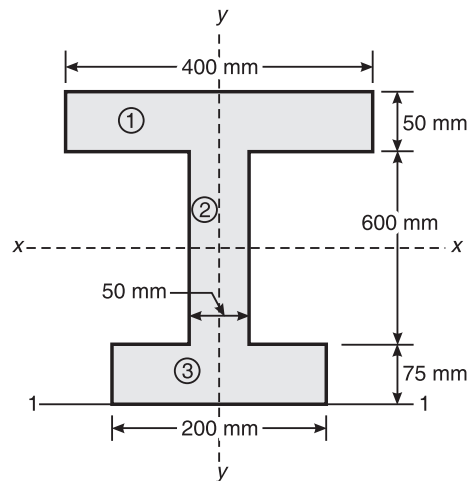

Figure 10.11 Example 10.1.

Solution The given figure is symmetrical about the y -axis. Therefore, the centroidal y -axis coincides with the reference y -axis. Hence $\bar{x} = 0$.

Moment of inertia about the centroidal x - x axis

$$I_{1-1} = \bar{I}_x + A\bar{y}^2 = \Sigma \bar{I}_x + \Sigma Ay^2$$

or

$$I_{1-1} - A\bar{y}^2 = \bar{I}_x$$

$$I_{2-2} = \bar{I}_y + A\bar{x}^2$$

| Comp. | Area (mm ²) | y | Ay (mm ³) | Ay^2 (mm ⁴) | \bar{I}_x (mm ⁴) | \bar{I}_y (mm ⁴) |
|----------|-----------------------------|------------------------------------|-------------------------------------|---------------------------|--|---|
| 1. | 400×50 = 20,000 | $75 + 600 + \frac{50}{2}$ = 700 | 14,000,000 = 14×10^6 | 9.8×10^9 | $\frac{400(50)^3}{12}$ = 4.167×10^6 | $\frac{50(400)^3}{12}$ = 266,666,666.7 |
| 2. | 50×600 = 30,000 | $75 + \frac{600}{2}$ = 375 | 11,250,000 = 11.25×10^6 | 4.219×10^9 | $\frac{50 \times 600^3}{12}$ = 900×10^6 | $\frac{600 \times 50^3}{12}$ = 6,250,000 |
| 3. | 200×75 = 15,000 | $\frac{75}{2} = 37.5$ | 562,500 | 21.09×10^6 | $\frac{200 \times 75^3}{12}$ = 7.03×10^6 | $\frac{75 \times 200^3}{12}$ = 5,00,00,000 |
| Σ | 65,000 | | 25.812×10^6 | 1.404×10^{10} | 911.197×10^6 | 322,916,666.7 |

$$\bar{y} = \frac{\Sigma Ay}{\Sigma A} = \frac{25.812 \times 10^6}{65,000} = 397.108 \text{ mm}$$

$$\bar{I}_{1-1} = \bar{I}_x + A \bar{y}^2 = \Sigma \bar{I}_x + \Sigma Ay^2 = 1.495 \times 10^{10} \text{ mm}^4$$

$$\bar{I}_x = \bar{I}_{1-1} - A \bar{y}^2 = 1.495 \times 10^{10} - 65000 \times (397.108)^2 = 4.691 \times 10^9 \text{ mm}^4 \quad \text{Ans.}$$

When the moment of inertia is required on a symmetrical axis, then

$$\bar{I}_y = \Sigma \bar{I}_y = 329,216,666.7 \text{ mm}^4 \quad \text{Ans.}$$

Example 10.2 Determine the moment of inertia of the unequal I-section about its centroidal axes as shown in Figure 10.12.

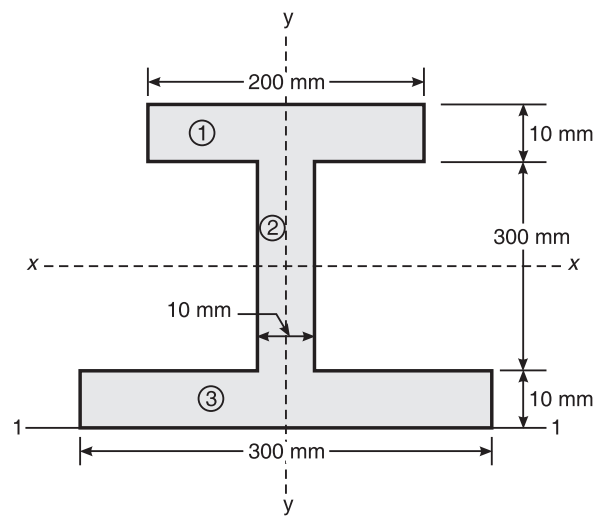

Figure 10.12 Example 10.2.

Solution

| Comp. | Area (mm ²) | y (mm) | Ay (mm ³) | Ay ² (mm ³) | \bar{I}_x (mm ⁴) | \bar{I}_y (mm ⁴) |
|-------|-------------------------|------------------------------------|-------------------------|------------------------------------|--|---|
| 1. | 200 × 10 = 2000 | 10 + 300 + $\frac{10}{2}$ = 315 | 6.3 × 10 ⁵ | 1.98 × 10 ⁸ | $\frac{200(10)^3}{12}$ = 16,666.67 | $\frac{10(200)^3}{12}$ = 6,666,666.67 |
| 2. | 300 × 10 = 3000 | 10 + $\frac{300}{2}$ = 160 | 4.8 × 10 ⁵ | 0.798 × 10 ⁸ | $\frac{10 \times 300^3}{12}$ = 225,00,000 | $\frac{300 \times 10^3}{12}$ = 25,000 |
| 3. | 300 × 10 = 3000 | $\frac{10}{2} = 5$ | 0.15 × 10 ⁵ | 75 × 10 ³ | $\frac{300 \times 10^3}{12}$ = 25,000 | $\frac{10 \times 300^3}{12}$ = 2,25,00,000 |
| Σ | 8000 | | 11.25 × 10 ⁵ | 2.75 × 10 ⁸ | 22,541,666.67 | 29,191,666.7 |

258 ELEMENTS OF CIVIL ENGINEERING AND ENGINEERING MECHANICS

$$\bar{y} = \frac{\Sigma Ay}{\Sigma a} = \frac{11.25 \times 10^5}{8000} = 140.625 \text{ mm}$$

$$I_{1-1} = \bar{I}_x + A \bar{y}^2 = \Sigma \bar{I}_x + \Sigma Ay^2 = 22,541,666.67 + 2.75 \times 10^8 = 297,541,666.67 \text{ mm}^4$$

$$\bar{I}_x = I_{1-1} - A \bar{y}^2 = 297,541,666.67 - 8000 \times (140.625)^2 = 139,338,541.67 \text{ mm}^4 \quad \text{Ans.}$$

$$\bar{I}_y = 29,191,666.7 \text{ mm}^4 \quad \text{Ans.}$$

Example 10.3 Determine the moment of inertia of the section, shown in Figure 10.13, about its centroidal axes. Calculate the least radius of gyration for the section as well.

VTU (February 2003)

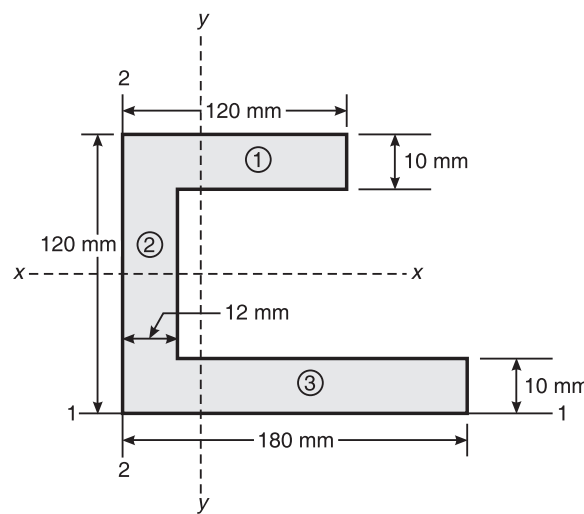

Figure 10.13 Example 10.3.

Solution

| Comp. | Area | x | y | Ax | Ay | Ax^2 | Ay^2 |
|----------|-----------------------------|----------------------|---------------------------------|---------------------|--------------------|----------------------|----------------------|
| 1. | 120×10 $= 1200$ | $\frac{30}{2} = 60$ | $120 - \frac{10}{2}$ $= 115$ | 72×10^3 | 138×10^3 | 4.32×10^6 | 15.87×10^6 |
| 2. | 12×100 $= 1200$ | $\frac{12}{2} = 6$ | $\frac{120}{2} = 60$ | 7.2×10^3 | 72×10^3 | 43.2×10^3 | 4.32×10^6 |
| 3. | 180×10 $= 1800$ | $\frac{180}{2} = 90$ | $\frac{10}{2} = 5$ | 162×10^3 | 9×10^3 | 14.58×10^6 | 45×10^3 |
| Σ | 4200 | | | 2.412×10^5 | 2.19×10^5 | 18.943×10^6 | 20.235×10^6 |

| Comp. | \bar{I}_x (mm ⁴) | \bar{I}_y (mm ⁴) |
|----------|--|--|
| 1. | $\frac{120(10)^3}{12} = 10,000$ | $\frac{10(120)^3}{12} = 1,440,000$ |
| 2. | $\frac{12 \times 100^3}{12} = 1,000,000$ | $\frac{100 \times 12^3}{12} = 14,400$ |
| 3. | $\frac{180 \times 10^3}{12} = 15,000$ | $\frac{10 \times 180^3}{12} = 4,861,800$ |
| Σ | 1.025×10^6 | 6.3162×10^6 |

$$\bar{x} = \frac{\Sigma Ax}{\Sigma A} = 57.428 \text{ mm} \quad \text{and} \quad \bar{y} = \frac{\Sigma Ay}{\Sigma A} = \frac{2.19 \times 10^5}{4200} = 52.143 \text{ mm}$$

$$I_{1-1} = \Sigma \bar{I}_x + \Sigma Ay^2 = 1.025 \times 10^6 + 20.235 \times 10^6 = 21.26 \times 10^6 \text{ mm}^4$$

$$\bar{I}_x = I_{1-1} - A \bar{y}^2 = 21.26 \times 10^6 - 4200 \times (52.143)^2 = 9.841 \times 10^6 \text{ mm}^4 \quad \text{Ans.}$$

$$I_{2-2} = \Sigma \bar{I}_y + \Sigma Ax^2 = 6.3162 \times 10^6 + 18.943 \times 10^6 = 25.2592 \times 10^6 \text{ mm}^4$$

$$\bar{I}_y = I_{2-2} - A \bar{x}^2 = 25.2592 \times 10^6 - 4200 \times (57.428)^2 = 11.4077 \times 10^6 \text{ mm}^4 \quad \text{Ans.}$$

$$\bar{I}_x = 9.841 \times 10^6 \text{ mm}^4$$

\therefore Radii of gyration

$$k_x = \sqrt{\frac{\bar{I}_x}{A}} = \sqrt{\frac{9.841 \times 10^6}{4200}} = 48.406 \text{ mm} \quad \text{and} \quad k_y = \sqrt{\frac{\bar{I}_y}{A}} = \sqrt{\frac{11.4077 \times 10^6}{4200}} = 52.1126 \text{ mm}$$

Least radius of gyration = 48.406 mm

Ans.

Example 10.4 Find the least radius of gyration about the x -axis and y -axis of the shaded area shown in Figure 10.14.

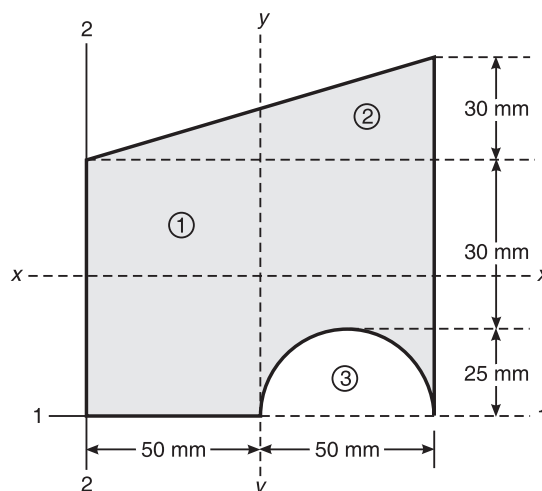

Figure 10.14 Example 10.4.

260 ELEMENTS OF CIVIL ENGINEERING AND ENGINEERING MECHANICS

Solution

| Component | Area (mm ²) | x (mm) | y (mm) | Ax | Ay | Ax ² | Ay ² |
|--------------|--|--------------------------------------|---------------------------------------|---------|-----------|-----------------|-----------------|
| Rectangle 1 | 55 × 100 = 5500 | 50 | $\frac{55}{2} = 27.5$ | 275,000 | 151,250 | 13,750,000 | 4,159,375 |
| Triangle 2 | $\frac{1}{2} \times 30 \times 100$ = 1500 | $\frac{2}{3} \times 100$ = 66.667 | 55 + 10 = 65 | 100,000 | 97,500 | 6,666,667 | 6,337,500 |
| Semicircle 3 | $-\frac{\pi \times (25)^2}{2}$ = -981.748 | 50 + 25 = 75 | $\frac{4 \times 25}{3\pi}$ = 10.61 | -73,631 | -10,416.7 | -5,522,326 | -110,524 |
| Sum | 6018.252 | | | 301,369 | 238,333.3 | 14,894,340 | 10,386,351 |

| Component | \bar{I}_x (mm ⁴) | \bar{I}_y (mm ⁴) |
|--------------|--|--|
| Rectangle 1 | $\frac{100 \times 55^3}{12} = 1,386,458$ | $\frac{55 \times 100^3}{12} = 4,583,333$ |
| Triangle 2 | $\frac{100 \times 30^3}{36} = 75,000$ | $\frac{30 \times 100^3}{36} = 833,333.3$ |
| Semicircle 3 | $-0.11(25)^4 = -42,968.8$ | $\frac{-\pi(25)^4}{8} = -153,398$ |
| Sum | 1,418,490 | 5,263,269 |

$$\bar{x} = \frac{\Sigma Ax}{\Sigma A} = \frac{3.014 \times 10^5}{6018.252} = 50.07582 \text{ mm}$$

$$\bar{y} = \frac{\Sigma Ay}{\Sigma A} = \frac{2.384 \times 10^5}{6018.252} = 39.60175 \text{ mm}$$

$$I_{x-x} = I_{1-1} - A \bar{y}^2$$

$$I_{1-1} = \Sigma \bar{I}_x + \Sigma Ay^2 = 1,418,490 + 10,386,351 = 11,804,840 \text{ mm}^4$$

$$I_{2-2} = \Sigma \bar{I}_y + \Sigma Ax^2 = 5,263,269 + 14,894,340 = 20,157,609 \text{ mm}^4$$

$$\bar{I}_x = I_{1-1} - A \bar{y}^2 = 11,804,840 - 6018.253 \times (39.602)^2 = 2,366,424 \text{ mm}^4$$

$$\bar{I}_y = I_{2-2} - A \bar{x}^2 = 20,157,609 - 6018.253 \times (50.076)^2 = 5,066,309 \text{ mm}^4$$

$$k_x = \sqrt{\frac{\bar{I}_x}{A}} = \sqrt{\frac{23,66,424}{6018.252}} = 19.829 \text{ mm}$$

Ans.

and $k_y = \sqrt{\frac{\bar{I}_y}{A}} = \sqrt{\frac{50,66,309}{6018.253}} = 29.014 \text{ mm}$

Ans.

Example 10.5 Find the polar radius of gyration for the area shown in Figure 10.15.

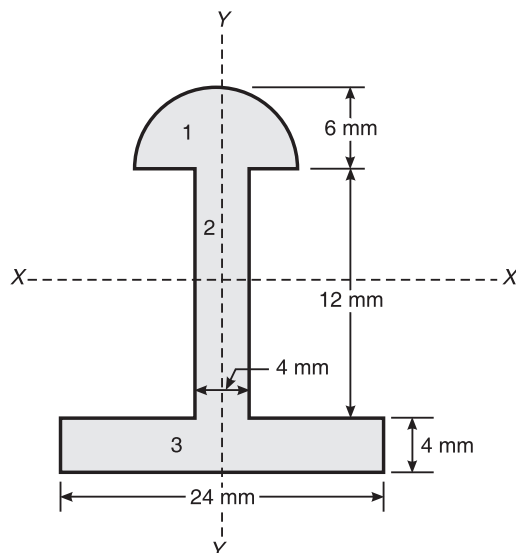

Figure 10.15 Example 10.5.

Solution

| Component | Area (mm ²) | y (mm) | Ay (mm ³) | Ay ² (mm ⁴) |
|--------------|-------------------------------------|---|-----------------------|------------------------------------|
| Semicircle 1 | $\frac{\pi \times 6^2}{2} = 56.549$ | $16 + \frac{4 \times 6}{3\pi} = 18.546$ | 1.049×10^3 | 19.45×10^3 |
| Rectangle 2 | $4 \times 12 = 48$ | $4 + \frac{12}{2} = 10$ | 0.48×10^3 | 4.8×10^3 |
| Rectangle 3 | $24 \times 4 = 96$ | $\frac{4}{2} = 2$ | 0.192×10^3 | 0.384×10^3 |
| Sum | 224.549 | | 1.721×10^3 | 24.634×10^3 |

| Component | \bar{I}_x (mm ⁴) | \bar{I}_{gy} (mm ⁴) |
|--------------|---|---------------------------------------|
| Semicircle 1 | $0.11 \times 6^4 = 142.56$ | $\frac{\pi \times 6^4}{8} = 508.9376$ |
| Rectangle 2 | $\frac{b^2 d_2^3}{12} = \frac{6 \times 12^3}{12} = 864$ | $\frac{12 \times 6^3}{12} = 216$ |
| Rectangle 3 | $\frac{b_3 d_3^2}{12} = \frac{24 \times 4^3}{12} = 128$ | $\frac{4 \times 24^3}{12} = 4608$ |
| Sum | 1134.56 | 5332.938 |

262 ELEMENTS OF CIVIL ENGINEERING AND ENGINEERING MECHANICS

$$\bar{y} = \frac{\Sigma Ay}{\Sigma A} = \frac{1960.75}{224.549} = 8.731 \text{ mm}$$

$$I_{1-1} = \Sigma \bar{I}_x + \Sigma Ay^2 = 1134.56 + 27,034.26 = 28.1688 \times 10^3 \text{ mm}^4$$

$$\bar{I}_x = I_{1-1} - A \bar{y}^2 = 28.1688 \times 10^3 - 224.549 \times (8.731)^2 = 11051.349 \text{ mm}^4$$

$$\bar{I}_y = 5332.938 \text{ mm}^4$$

$$\bar{I}_z = \bar{I}_x + \bar{I}_y = 11051.349 + 5332.938 = 16.384 \times 10^3 \text{ mm}^4$$

$$k_z = \sqrt{\frac{\bar{I}_z}{A}} = \sqrt{\frac{16.384 \times 10^3}{224.549}} = \sqrt{72.965} = 8.542 \text{ mm}$$

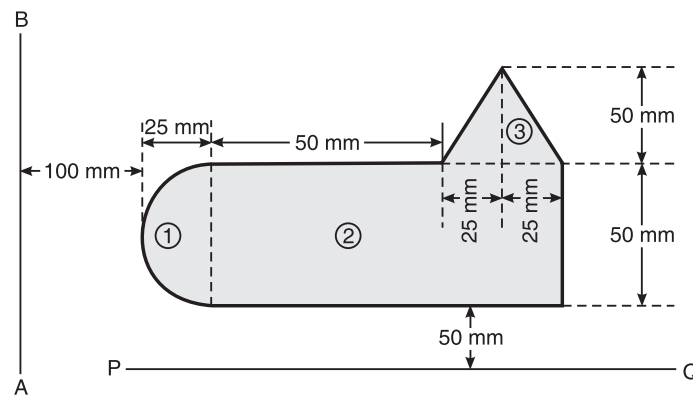
Ans.**Example 10.6** Determine the moment of inertia about PQ and AB of the plane lamina (Figure 10.16).**Figure 10.16** Example 10.6.**Solution**

| Component | Area | x | y | $Ax \times 10^3$ | $Ay \times 10^3$ | $Ax^2 \times 10^6$ | $Ay^2 \times 10^6$ |
|--------------|---|---|---------------------------------|------------------|------------------|--------------------|--------------------|
| Semicircle 1 | $\frac{\pi \times (25)^2}{2}$ = 981.748 | $100 + 25 - \frac{4 \times 25}{3\pi}$ = 135.61 | $50 + \frac{50}{2}$ = 75 | 112.301 | 73.631 | 12.846 | 5.522 |
| Rectangle 2 | 100×50 = 5000 | $50 + 25 + 100$ | $50 + \frac{50}{2}$ = 75 | 875 | 375 | 153.125 | 28.125 |
| Triangle 3 | $\frac{1}{2} \times 50 \times 50$ = 1250 | $25 + 50 + 25 + 100$ = 200 | $\frac{50}{3} + 10$ = 116.66 | 250 | 145.834 | 50 | 17.014 |
| Sum | 7231.748 | | | 1237.3 | 594.465 | 215.971 | 50.661 |

| Component | \bar{I}_x | \bar{I}_y |
|--------------|--|---|
| Semicircle 1 | $\frac{\pi(25)^4}{8} = 0.153 \times 10^6$ | $0.11(25)^4 = 0.043 \times 10^6$ |
| Rectangle 2 | $\frac{100 \times 50^3}{12} = 1.042 \times 10^6$ | $\frac{100^3 \times 50}{12} = 4.167 \times 10^6$ |
| Triangle 3 | $\frac{50 \times 50^3}{36} = 0.174 \times 10^6$ | $\frac{50 \times 50^3}{48} = 130.208 \times 10^3$ |
| Sum | 1.369×10^6 | 4.34×10^6 |

$$I_{PQ} = \Sigma \bar{I}_x + \Sigma Ay^2 = 1.369 \times 10^6 + 50.661 \times 10^6 = 52.03 \times 10^6 \text{ mm}^4 \quad \text{Ans.}$$

$$I_{AB} = \Sigma \bar{I}_y + \Sigma Ax^2 = (4.34 + 215.971) \times 10^6 = 220.311 \times 10^6 \text{ mm}^4 \quad \text{Ans.}$$

Example 10.7 Determine the moment of inertia about the horizontal axis of the plane lamina (Figure 10.17). Also find k about the horizontal axis.

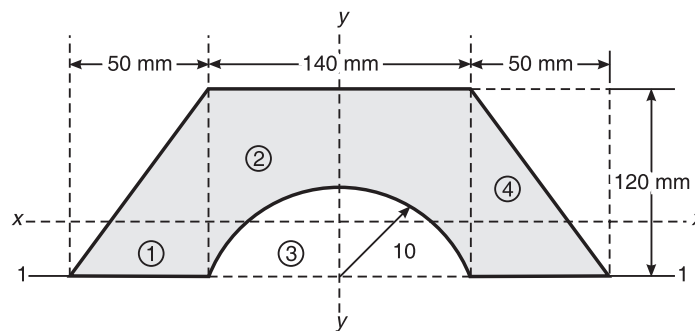

Figure 10.17 Example 10.7.

Solution

| Component | Area | y | Ay | Ay^2 | \bar{I}_x |
|--------------|--|------------------------------------|----------------------|----------------------|--|
| Triangle 1 | $\frac{1}{2} \times 50 \times 120$ $= 3000$ | $\frac{1}{3} \times 120$ $= 40$ | 1.2×10^5 | 4.8×10^6 | $\frac{50 \times 120^3}{36}$ $= 2.4 \times 10^6$ |
| Rectangle 2 | 140×120 $= 16,800$ | $\frac{120}{12} = 60$ | 10.08×10^6 | 60.48×10^6 | $\frac{140 \times 120^3}{12}$ $= 20.16 \times 10^6$ |
| Semicircle 3 | $-\frac{\pi \times (70)^2}{2}$ | $\frac{4 \times 70}{3\pi}$ | -2.887×10^5 | -6.793×10^6 | $0.11 \times (R^4)$ $= -2.64 \times 10^6$ |
| Triangle 4 | $\frac{1}{2} \times 50 \times 120$ $= 3000$ | $\frac{1}{3} \times 120$ $= 40$ | 1.2×10^5 | 4.8×10^6 | 2.4×10^6 (Same as Triangle 1) |
| Sum | 15,103.098 | | 9.593×10^5 | 63.287×10^6 | 22.32×10^6 |

264 ELEMENTS OF CIVIL ENGINEERING AND ENGINEERING MECHANICS

$$I_{1-1} = \bar{I}_x + A \bar{y}^2$$

$$I_{1-1} = \Sigma \bar{I}_x + \Sigma A \bar{y}^2 = (22.32 + 63.287) \times 10^6 = 85.607 \times 10^6 \text{ mm}^4$$

$$I_x = I_{1-1} - A \bar{y}^2 = 85.607 \times 10^6 - 15,103.098 \times (63.516)^2 = 24.677 \times 10^6 \text{ mm}^4 \quad \text{Ans.}$$

$$k_x = \sqrt{\frac{\bar{I}_x}{A}} = \sqrt{\frac{24.677 \times 10^6}{15,103.098}} = 40.421 \text{ mm} \quad \text{Ans.}$$

Example 10.8 Find the polar moment of inertia of the plane lamina (Figure 10.18) about point O .

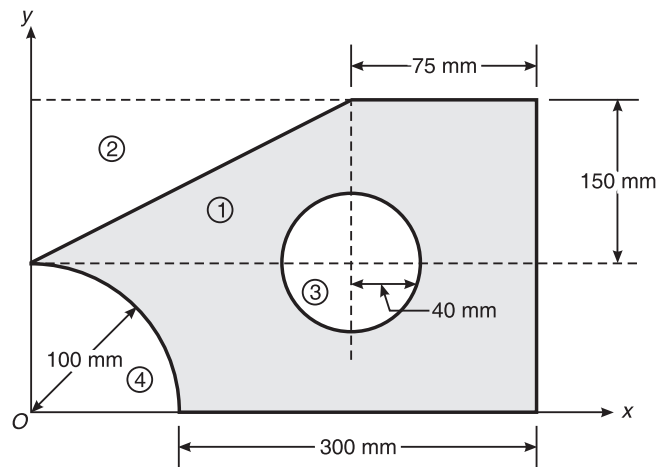

Figure 10.18 Example 10.8.

Solution

| Component | Area (mm ²) | x (mm) | y (mm) | $Ax \times 10^6$ | $Ay \times 10^6$ | $Ax^2 \times 10^9$ | $Ay^2 \times 10^9$ |
|-------------|---|---|---|------------------|------------------|--------------------|--------------------|
| Rectangle 1 | 400×250 $= 100,000$ | $\frac{400}{2} = 200$ | $\frac{250}{2} = 125$ | 20 | 12.5 | 4 | 1.563 |
| Triangle 2 | $\frac{1}{2} \times 325 \times 150$ $= 24.375 \times 10^3$ | $\frac{1}{3} \times 325$ $= 108.333$ | $100 + \frac{2}{3} \times 150$ $= 200$ | -2.641 | -4.875 | -0.286 | -0.975 |
| Circle 3 | $-\pi(40)^2$ $= -5.027 \times 10^3$ | $400 - 75$ $= 325$ | 100 | -1.634 | -0.503 | -0.531 | -0.05 |
| Quadrant 4 | $-\frac{\pi \times (100)^2}{4}$ $= -7.854 \times 10^3$ | $\frac{4 \times 100}{3\pi}$ $= 42.441$ | $\frac{4 \times 100}{3\pi}$ $= 42.441$ | -0.333 | -0.333 | -0.014 | -0.014 |
| Sum | 62.744×10^3 | | | 15.392 | 6.789 | 3.169 | 0.524 |

| Component | \bar{I}_x (mm ⁴) | \bar{I}_y (mm ⁴) |
|-------------|---|---|
| Rectangle 1 | $\frac{400 \times 250^3}{12} = 521 \times 10^9$ | $\frac{250 \times 400^3}{12} = 1.333 \times 10^9$ |
| Triangle 2 | $-\frac{325 \times 150^3}{36} = -0.305 \times 10^8$ | $\frac{150 \times 325^3}{36} = 0.143 \times 10^9$ |
| Circle 3 | $-\frac{\pi(40)^4}{4} = -0.02 \times 10^8$ | -0.02×10^8 |
| Quadrant 4 | $-0.055 \times (100)^4 = -0.055 \times 10^8$ | -0.05×10^8 |
| Sum | 4.828×10^8 | 11.828×10^8 |

$$I_{Ox} = \Sigma \bar{I}_x + \Sigma Ay^2 = 4.828 \times 10^8 + 0.524 \times 10^9 = 1.0068 \times 10^9 \text{ mm}^4$$

$$I_{Oy} = \Sigma \bar{I}_y + \Sigma Ax^2 = 11.828 \times 10^8 + 3.169 \times 10^9 = 4.351 \times 10^9 \text{ mm}^4$$

$$I_{Oz} = I_{Ox} + I_{Oy} = 5.357 \times 10^9 \text{ mm}^4$$

Ans.

Example 10.9 Determine the moment of inertia of the plane lamina (Figure 10.19) about the x -axis.

VTU (February 2004)

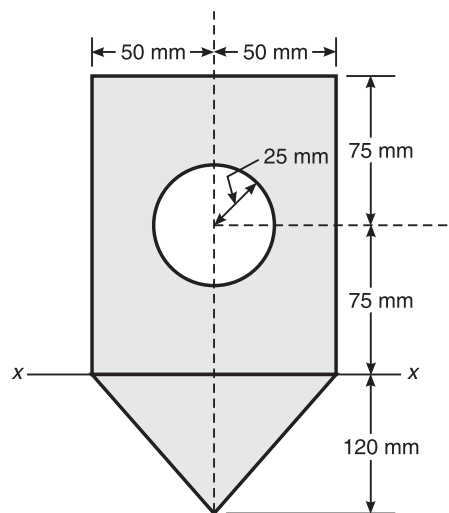

Figure 10.19 Example 10.9.

266 ELEMENTS OF CIVIL ENGINEERING AND ENGINEERING MECHANICS

Solution

| Component | Area | y | Ay^2 | \bar{I}_x |
|-------------|--|-------------------------------------|-----------------------------------|---|
| Rectangle 1 | 150×100 $= 15000$ | 75 | 84.375×10^6 | $\frac{100 \times 150^3}{12}$ $= 28.125 \times 10^6$ |
| Triangle 2 | $\frac{1}{2} \times 100 \times 20$ $= 6000$ | $\frac{1}{3} \times 120$ $= -40$ | 9.6×10^6 | $\frac{100 \times 120^3}{36}$ $= 4.8 \times 10^6$ |
| Circle 3 | $-\pi \times (25)^2$ $= -1963.495$ | 75 | -11.045×10^6 | $\frac{\pi \times (25)^4}{4}$ $= -0.307 \times 10^6$ |
| Sum | $\Sigma A = 19036.505$ | | $\Sigma Ay^2 = 82.93 \times 10^6$ | $\Sigma \bar{I}_x = 32.618 \times 10^6$ |

$$\bar{I}_x = \Sigma \bar{I}_x + \Sigma Ay^2 = (32.618 + 82.93)10^6 = 1.155 \times 10^8 \text{ mm}^4 \quad \text{Ans.}$$

Example 10.10 Find the radius of gyration of the shaded area about an axis normal to the symmetrical axis (Figure 10.20).

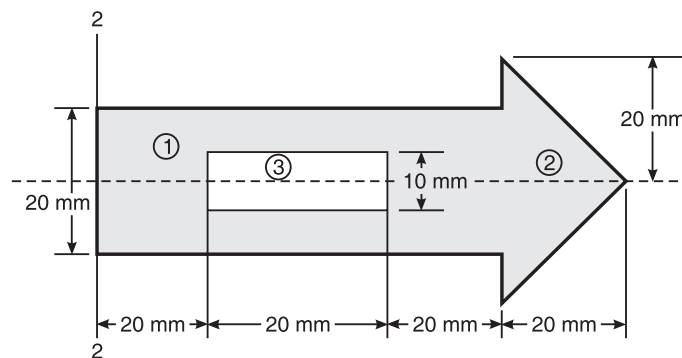

Figure 10.20 Example 10.10.

Solution

| Component | Area (mm ²) | x (mm) | Ax | Ax^2 | \bar{I}_y (mm ⁴) |
|-------------|--|--|----------------------|----------------------|--------------------------------|
| Rectangle 1 | $20 \times 70 = 1400$ | $\frac{70}{2} = 35$ | 49×10^3 | 1.715×10^6 | $\frac{20 \times 70^3}{12}$ |
| Triangle 2 | $\frac{1}{2} \times 20 \times 40$ $= 400$ | $70 + \frac{1}{3} \times 20$ $= 76.667$ | 30.667×10^3 | 2.351×10^6 | $\frac{40 \times 20^3}{36}$ |
| Rectangle 3 | -30×10 $= -300$ | $20 + 15 = 35$ | -10.5×10^3 | -0.367×10^6 | $-\frac{10 \times 30^3}{12}$ |
| Sum | $\Sigma A = 1500$ | | 69.167×10^3 | 3.699×10^6 | 558.056×10^3 |

$$\bar{x} = \frac{\Sigma Ax}{\Sigma A} = \frac{69.167 \times 10^3}{1500} = 46.111 \text{ mm}$$

$$I_{2-2} = \Sigma \bar{I}_x + \Sigma Ax^2 = 558.056 \times 10^3 + 3.699 \times 10^6 = 4.2567 \times 10^6 \text{ mm}^4$$

$$\bar{I}_y = I_{2-2} - A\bar{x}^2 = 4.2567 \times 10^6 - 1500 \times (46.111)^2 = 1.0674 \times 10^6 \text{ mm}^4 \quad \text{Ans.}$$

Example 10.11 Calculate the moment of inertia about the vertical centroidal axis of the plane lamina shown in Figure 10.21.

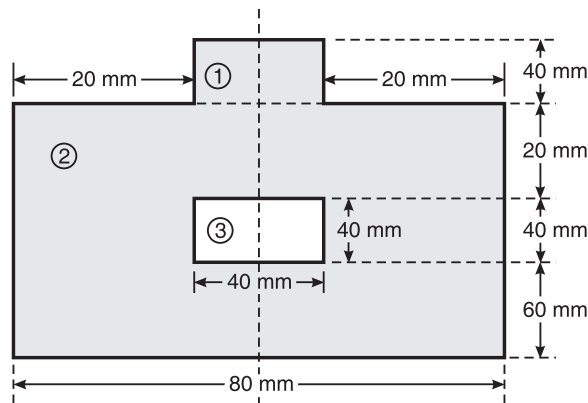

Figure 10.21 Example 10.11.

Solution The given plane figure is symmetric about the vertical centroidal axis.

$$\bar{I}_y = \Sigma \bar{I}_y = \frac{d_1 b_1^3}{12} + \frac{d_2 b_2^3}{12} - \frac{d_3 b_3^3}{12}$$

$$= \frac{40 \times 40^3}{12} + \frac{120 \times 80^3}{12} - \frac{40 \times 40^3}{12} = 5.12 \times 10^6 \text{ mm}^4 \quad \text{Ans.}$$

Example 10.12 Determine the moment of inertia and radius of gyration of the area shown in Figure 10.22 about the base AB and centroidal axis parallel to AB. *VTU (January 2007)*

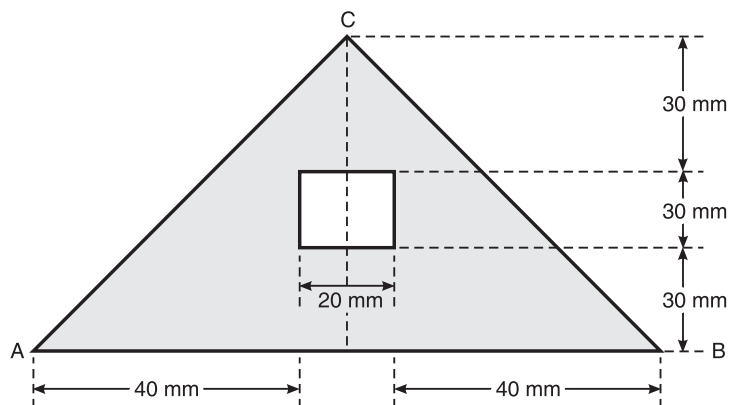

Figure 10.22 Example 10.12.

Solution

| Component | Area | y | $Ay \times 10^3$ | $Ay^2 \times 10^6$ | \bar{I}_x |
|-------------|--|------------------------------|------------------|-----------------------|---|
| Triangle 1 | $\frac{1}{2} \times 100 \times 90$ = 4500 | $\frac{1}{3} \times 90 = 30$ | 135 | 4.05 | $\frac{100 \times 90^3}{36}$ = 2.025×10^6 |
| Rectangle 2 | $20 \times 30 = -600$ | $30 + \frac{30}{2} = 45$ | -27 | -1.215 | $-\frac{20 \times 30^3}{12}$ = -45×10^3 |
| Sum | $\Sigma A = 3900$ | | 108 | $\Sigma Ay^2 = 2.835$ | $\Sigma \bar{I}_x = 1.98 \times 10^6$ |

$$\bar{y} = \frac{\Sigma Ay}{\Sigma A} = \frac{108 \times 10^3}{3900} = 27.69 \text{ mm}$$

Moment of inertia about the base AB = $I_{AB} = \bar{I}_x + A \bar{y}^2$

$$I_{AB} = \Sigma \bar{I}_x + \Sigma Ay^2 = 1.98 \times 10^6 + 2.835 \times 10^6 = 4.815 \times 10^6 \text{ mm}^4$$

$$\therefore I_{AB} = 4.815 \times 10^6 \text{ mm}^4 \quad \text{Ans.}$$

Moment of Inertia about centroidal x-axis = $\bar{I}_x = I_{1-1} - A \bar{y}^2$

$$\bar{I}_x = 4.815 \times 10^6 - 3900(27.692)^2 = 1.824 \times 10^6 \text{ mm}^4 \quad \text{Ans.}$$

Radius of gyration about AB,

$$k_{AB} = \sqrt{\frac{I_{AB}}{A}} = 35.13 \text{ mm} \quad \text{Ans.}$$

Radius of gyration about the centroidal x-axis,

$$k_x = \sqrt{\frac{\bar{I}_x}{A}} = 21.63 \text{ mm} \quad \text{Ans.}$$

Example 10.13 Compute the second moment of built-up area shown in Figure 10.23 about its horizontal centroidal axis and find the corresponding radius of gyration (all dimensions in mm).

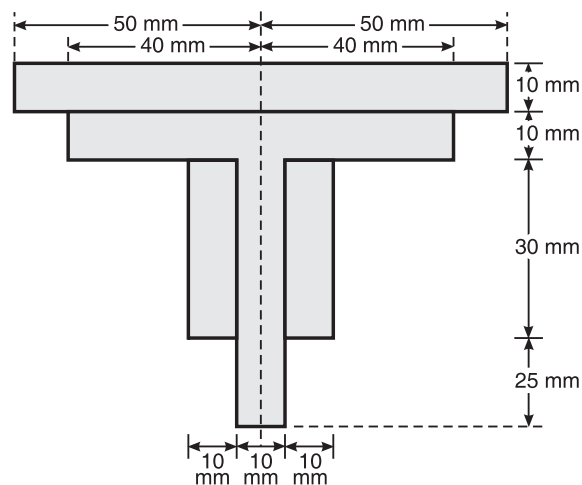

Figure 10.23 Example 10.13.

Solution

| Component | A (mm ²) | y (mm) | Ay | Ay ² | \bar{I}_x (mm ⁴) |
|-------------|----------------------|--|--------|--------------------------|--|
| Rectangle 1 | 100 × 10 = 1000 | $\frac{1}{2} \times 10 + 10$ + 30 + 25 = 70 | 70000 | 4900000 | $\frac{1}{12} \times 100 \times 10^3$ = 8333.334 |
| Rectangle 2 | 80 × 10 = 800 | $\frac{1}{2} \times 10 + 30$ + 25 = 60 | 48000 | 2.88 × 10 ⁶ | $\frac{1}{12} \times 80 \times (10)^3$ = 6666.667 |
| Rectangle 3 | 30 × 30 = 900 | $\frac{1}{2} \times 30 + 25 = 40$ | 36000 | 1.44 × 10 ⁶ | $\frac{1}{12} \times 30 \times 30^3$ = 67500 |
| Rectangle 4 | 10 × 25 = 250 | $\frac{1}{2} \times 25 = 12.5$ | 3,125 | 39.062 × 10 ³ | $\frac{1}{12} \times 10 \times 25^3$ = 13020.833 |
| Sum | 2950 | | 157125 | 9.259 × 10 ⁶ | 95520.834 |

$$\bar{y} = \frac{\Sigma Ay}{\Sigma A} = \frac{157125}{2950} = 53.26 \text{ mm}$$

We know that

$$I_{AB} = \bar{I}_x + A \bar{y}^2 \quad \text{where } I_{AB} = \text{moment of inertia about the base}$$

$$I_{1-1} = \Sigma \bar{I}_x + \Sigma Ay^2 = 95520.834 + 9.259 \times 10^6 = 9.354 \times 10^6 \text{ mm}^4$$

Moment of inertia about the centroidal x -axis = $\bar{I}_x = I_{AB} - A \bar{y}^2$

$$\therefore \bar{I}_x = 9.354 \times 10^6 - 2950(53.26)^2 = 9.354 \times 10^6 - 8.368 \times 10^6$$

$$\text{or } \bar{I}_x = 9.86 \times 10^5 \text{ mm}^4 \quad \text{Ans.}$$

$$\text{Radius of gyration, } k_x = \sqrt{\frac{\bar{I}_x}{A}} = \sqrt{\frac{9.86 \times 10^5}{2950}} = 18.282 \text{ mm} \quad \text{Ans.}$$

Example 10.14 Compute the moment of inertia of the area shown in Figure 10.24 about the axis AB.

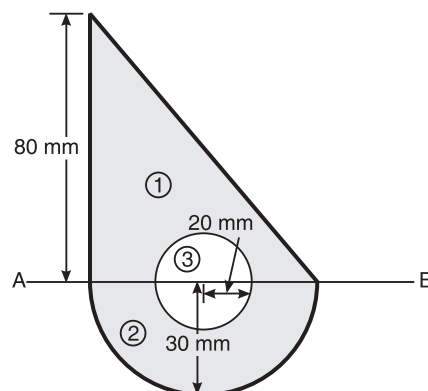

Figure 10.24 Example 10.14.

270 ELEMENTS OF CIVIL ENGINEERING AND ENGINEERING MECHANICS

Solution

| Component | A (mm^2) | y (mm) | Ay | Ay^2 | \bar{I}_x (mm^4) |
|--------------|---|--|------------|---------------------|--|
| Triangle 1 | $\frac{1}{2} \times 60 \times 80$ $= 2400$ | $\frac{80}{3} = 26.67$ | 64000.8 | 1.707×10^6 | $60 \times \frac{(80)^3}{36}$ $= 853.333 \times 10^3$ |
| Semicircle 2 | $\frac{\pi \times 30^2}{2}$ $= 1413.72$ | $\frac{4 \times 30}{3\pi}$ $= 12.732$ | -17999.432 | 2.292×10^5 | $+0.11(30)^4$ $= +89.1 \times 10^3$ |
| Circle 3 | $-\frac{\pi \times 20^2}{2}$ $= -1256.637$ | 0 | 0 | 0 | $-\frac{\pi \times 20^4}{4}$ $= -125.663 \times 10^3$ |
| Sum | 2557.079 | | 46001.368 | 1.936×10^6 | 816.77×10^3 |

$$I_{AB} = \Sigma \bar{I}_x + \Sigma Ay^2 = 816.77 \times 10^3 + 1.936 \times 10^6 = 2.753 \times 10^6 \text{ mm}^4 \quad \text{Ans.}$$

EXERCISE PROBLEMS

1. Figure 10.25 shows the T-section of dimensions $10 \times 10 \times 2$. Determine the moment of inertia of the section at the horizontal and vertical axes, passing through the centre of gravity of section.
[Ans.: $\bar{y} = 8$ cm, $\bar{I}_x = 533.33$ cm⁴, $\bar{I}_y = 173.3$ cm⁴]

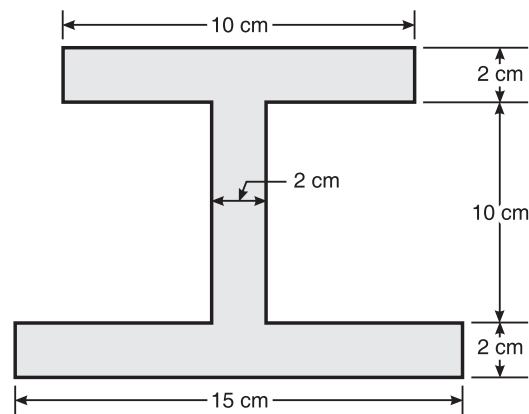

Figure 10.25

2. Find the moment of inertia of the section shown in Figure 10.26 at the centroidal axis perpendicular to the web. [Ans.: $\bar{y} = 6.14 \text{ mm}$, $\bar{I}_x = 1931.9 \text{ mm}^4$]

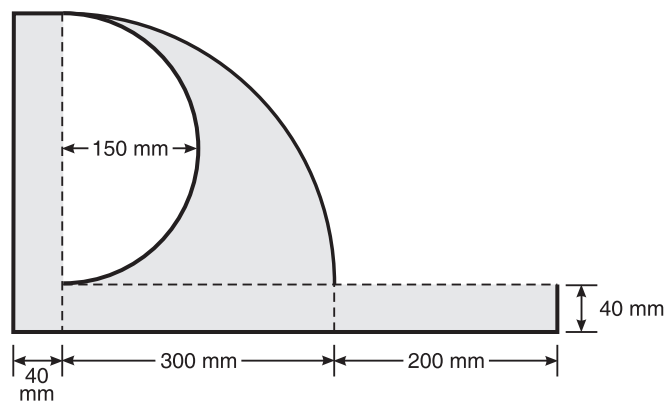

Figure 10.26

3. Determine the moment of inertia of Figure 10.27 about its centroidal y-axis. [Ans.: $\bar{x} = 18.73 \text{ mm}$, $\bar{y} = 16.67 \text{ mm}$, $\bar{I}_{xy} = 157.697 \times 10^3 \text{ mm}^4$, $\bar{I}_y = 191.859 \times 10^3 \text{ mm}^4$]

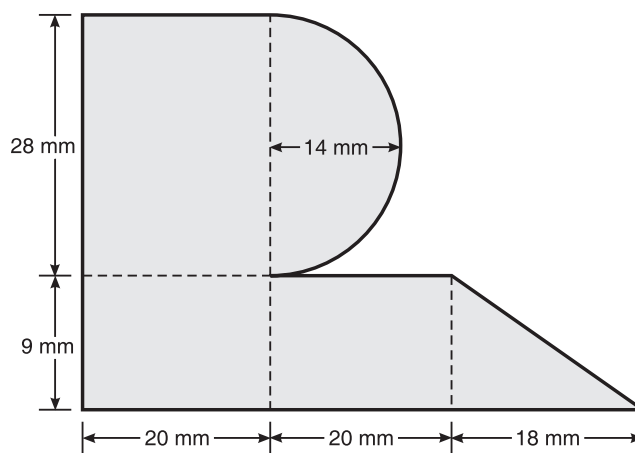

Figure 10.27

272 ELEMENTS OF CIVIL ENGINEERING AND ENGINEERING MECHANICS

4. Determine the moment of inertia of the shaded area about the reference axis (Figure 10.28).

[Ans.: $\bar{x} = 152.17 \text{ mm}$, $\bar{y} = 97.57 \text{ mm}$,
 $I_x = 293,066,492 \text{ mm}^4$, $I_y = 612,858,337 \text{ mm}^4$]

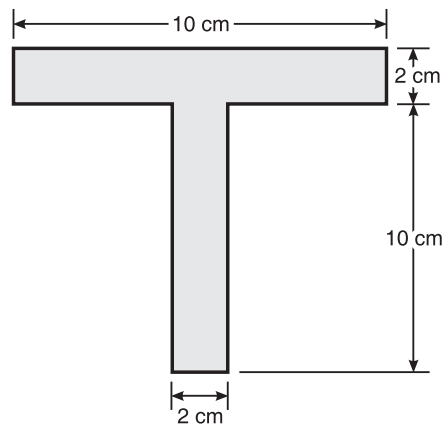

Figure 10.28

5. For the given plane shaded lamina shown in Figure 10.29, find the centroidal moment of inertia.

[Ans.: $\bar{x} = 206.485 \text{ mm}$ and $\bar{y} = 113.489 \text{ mm}$, $\bar{I}_x = 596,579,222.76 \text{ mm}^4$
and $\bar{I}_y = 1,115,487,437.16 \text{ mm}^4$]

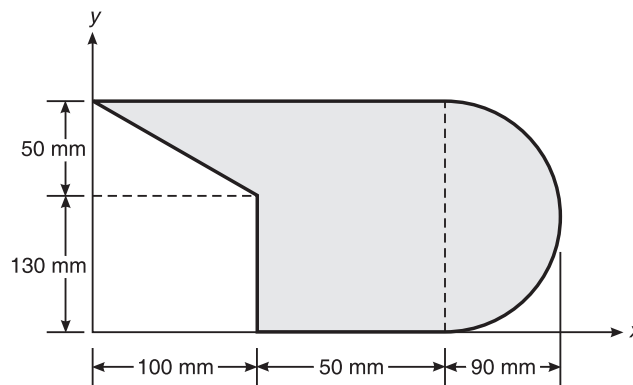

Figure 10.29

6. Find the moment of inertia of shaded area shown in Figure 10.30 about the centroidal axis.

[Ans.: $\bar{x} = 34.98$, $\bar{y} = 23.0$, $\bar{I}_x = 428,941.9 \text{ mm}^4$ and $\bar{I}_y = 132,414.9 \text{ mm}^4$]

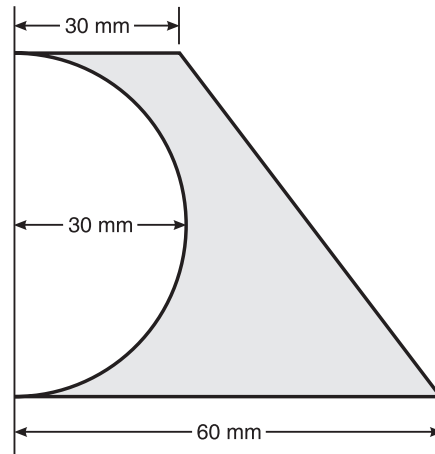

Figure 10.30

7. Find the moment of inertia of Figure 10.31 about the centroidal vertical axis (all dimensions in mm).

[Ans.: $\bar{x} = 0$, $\bar{y} = 89.17$, $\bar{I}_x = 26,271,023 \text{ mm}^4$ and $\bar{I}_y = 48,211,799.1 \text{ mm}^4$]

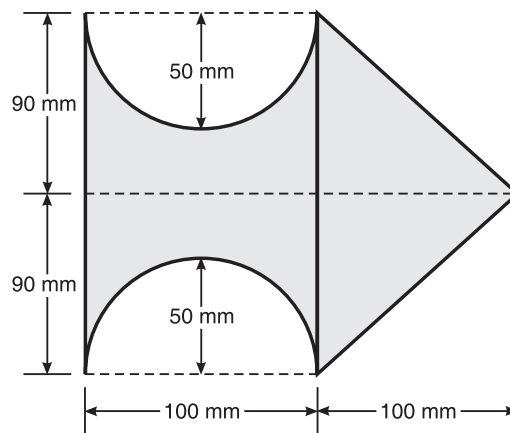

Figure 10.31

INTRODUCTION TO DYNAMICS

Dynamics is the branch of science which deals with the study of behaviour of body or particle in the state of motion under the action of force system. The first significant contribution to dynamics was made by Galileo in 1564. Later, Newton formulated the fundamental laws of motion.

Dynamics branches into two streams called kinematics and kinetics.

Kinematics is the study of relationship between displacement, velocity, acceleration and time of the given motion without considering the forces that causes the motion, or **Kinematics** is the branch of dynamics which deals with the study of properties of motion of the body or particle under the system of forces without considering the effect of forces.

Kinetics is the study of the relationships between the forces acting on the body, the mass of the body and the motion of body, or **Kinetics** is the branch of dynamics which deals with the study of properties of motion of the body or particle in such way that the forces which cause the motion of body are mainly taken into consideration.

TECHNICAL TERMS RELATED TO MOTION

Motion: A body is said to be in motion if it is changing its position with respect to a reference point.

Path: It is the imaginary line connecting the position of a body or particle that has been occupied at different instances over a period of time. This path traced by a body or particle can be a straight line/liner or curvilinear.

Displacement and Distance Travelled

Displacement is a vector quantity, measure of the interval between two locations or two points, measured along the shortest path connecting them. Displacement can be positive or negative.

Distance is a scalar quantity, measure of the interval between two locations measured along the actual path connecting them. Distance is an absolute quantity and always positive.

A particle in a rectilinear motion occupies a certain position on the straight line. To define this position P of the particle we have to choose some convenient reference point O called origin (Figure 11.1). The distance ' x_1 ' of the particle from the origin is called displacement.

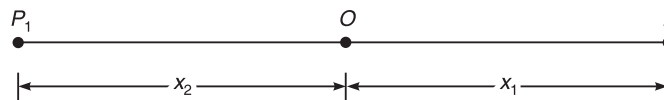

Figure 11.1

Let,

' P ' → Position of the particle at any time t_1

' x_1 ' → Displacement of particle measured in +ve direction of O

' x_2 ' → Displacement of particle measured in -ve direction of O

In this case the total distance travelled by a particle from point O to P to P_1 and back to O is not equal to displacement.

Total distance travelled = $x_1 + x_1 + x_2 + x_2 = 2(x_1 + x_2)$.

Whereas the net displacement is zero.

Velocity: Rate of change of displacement with respect to time is called velocity denoted by v .

∴ Mathematically $v = \frac{dx}{dt}$

Average velocity: When an object undergoes change in velocities at different instances, the average velocity is given by the sum of the velocities at different instances divided by the number of instances. That is, if an object has different velocities $v_1, v_2, v_3, \dots, v_n$, at times $t = t_1, t_2, t_3, \dots, t_n$, then the average velocity is given by

$$v = \frac{[v_1 + v_2 + v_3 + \dots + v_n]}{n}$$

Instantaneous velocity: It is the velocity of moving particle at a certain instant of time. To calculate the instantaneous velocity Δx is considered as very small.

$$\text{Instantaneous velocity } v = \Delta t \rightarrow 0 \frac{\Delta x}{\Delta t}$$

Speed: Rate of change of distance travelled by the particle with respect to time is called speed.

Acceleration: Rate of change of velocity with respect to time is called acceleration

$$\text{Mathematically } a = \frac{dv}{dt}$$

Average Acceleration

Consider a particle P situated at a distance of x from O at any instant of time t having a velocity v . Let P_1 be the new position of particle at a distance of $(x + \Delta x)$ from origin with a velocity of $(v + \Delta v)$. See Figure 11.2.

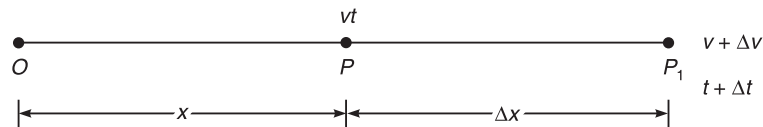

Figure 11.2

Average acceleration over a time t , is given by, $a_{\text{avg}} = \frac{\Delta v}{\Delta t}$

Acceleration due to gravity: Each and everybody is attracted towards the centre of the earth by a gravitational force and the acceleration with which the body is pulled towards the centre of the earth due to gravity is denoted by 'g'. The value of g is normally taken as 9.81 m/s^2 .

Newton's Laws of Motion

Newton's first law: This law states that 'everybody continues in its state of rest or of uniform motion, so long as it is under the influence of a balanced force system'.

Newton's second law: This law states that 'the rate of change momentum of a body is directly proportional to the impressed force and it takes place in the direction of force acting on it.

Newton's third law: This law states that 'action and reaction are equal in magnitude but opposite in direction'.

Types of Motion

1. Rectilinear motion
2. Curvilinear motion
3. Projectile motion

Graphical representation: The problems in dynamics can be analysed both analytically and graphically without compromising on the accuracy. Most of the times graphical representations can lead to simpler solutions to complicated problems. Using the simple terms defined in the initial portions of the section, we can draw different types of graphs.

Displacement–time graph: The representation with graph in Figure 11.3 shows that the displacement is uniform with time. Hence it is understood that the body is under rest as the displacement is constant with respect to time.

The representation with graph in Figure 11.4 shows that the plot is having a constant slope and the variation of displacement is uniform with time. The slope indicates the ratio of displacement to time which is equal to velocity of the body. Hence it is understood that the body is moving under uniform velocity.

Figure 11.5 shows variation of displacement with time as a curve. The tangent to this curve at any point indicates the velocity of the body at that instant. As can be seen the slope of the tangent is changing with respect to time and ever increasing, it indicates that the velocity is changing with respect to time and also indicates that the velocity is increasing with respect to time. This increasing velocity with respect to time is termed acceleration.



Figure 11.3 Variation of displacement with time.

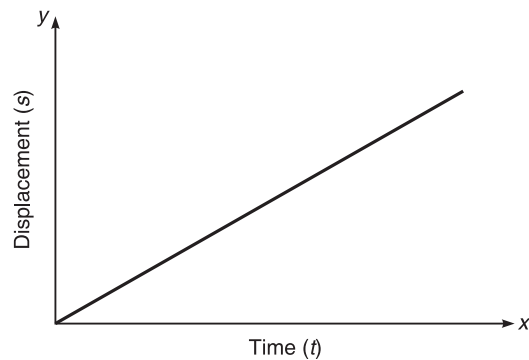

Figure 11.4 Variation of displacement with time.

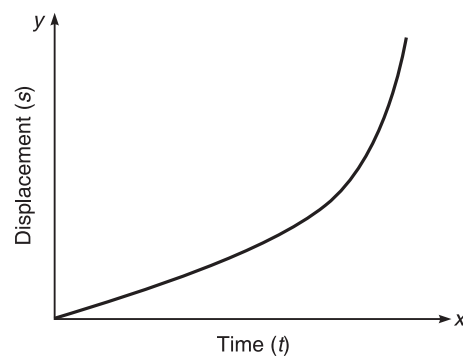

Figure 11.5 Variation of displacement with time.

278 ELEMENTS OF CIVIL ENGINEERING AND ENGINEERING MECHANICS

In case of Figure 11.6, the curvature is decreasing, and the slope of the tangent is decreasing with respect to time and rate change of velocity is decreasing. This is termed as deceleration.

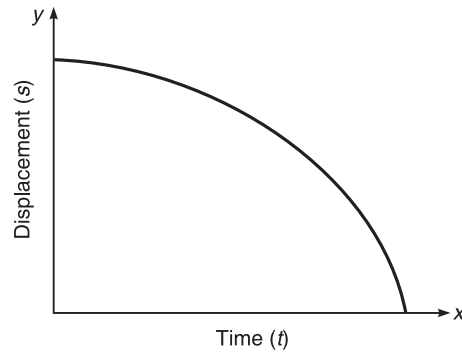

Figure 11.6 Variation of displacement with time.

Velocity–time graph: A plot of velocity with respect to time is termed as velocity–time graph (Figure 11.7).

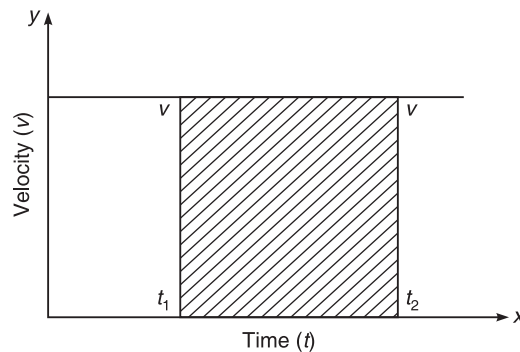

Figure 11.7 Variation of velocity with time.

$$\text{Unit of velocity} = v = LT^{-1}$$

$$\text{Unit of time} = T$$

$$\text{Velocity} \times \text{Time} = LT^{-1} \times T = L \rightarrow \text{Distance}$$

Hence, the area under V–T graph will produce the distance traveled by the body/particle from time t_1 to t_2

$$s = v \times (t_2 - t_1) = vt \quad (1)$$

This is applicable only when the velocity is uniform.

In case of Figure 11.8, the velocity is varying uniformly with respect to time as seen from sloped straight line.

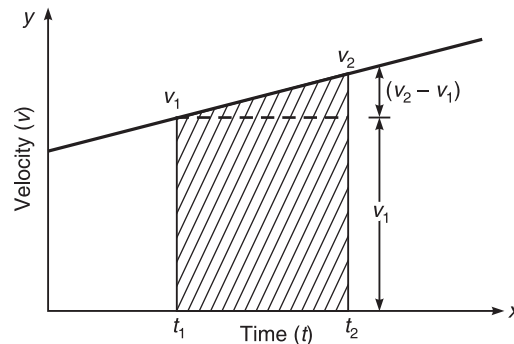

Figure 11.8 Variation of velocity with time.

The slope of the line is gives acceleration

$$a = \frac{(v_2 - v_1)}{(t_2 - t_1)}$$

$$(v_2 - v_1) = a(t_2 - t_1)$$

$$v_2 = v_1 + a(t_2 - t_1)$$

$$v = u + at$$

(1)

where v = final velocity, u = initial velocity and $t = (t_2 - t_1)$.

As seen from earlier graph, the total distance traveled is given by the area under the curve and hence the area is given as

$$s = v_1 \times t + \frac{1}{2} \times (v_2 - v_1)t$$

$$\text{But acceleration} = a = \frac{(v_2 - v_1)}{t}$$

Substituting, we get

$$s = v_1 \times t + \frac{1}{2} \times at^2 \text{ or } ut + \frac{1}{2} \times at^2$$

(2)

where u is the initial velocity or velocity at time t_1 .

Acceleration–time graph: It is a plot of acceleration versus time graph as shown in Figure 11.9. It is seen that the acceleration is constant with respect to time t . The same can be connected to velocity–time graph (Figure 11.6), wherein the velocity variation is constant.

The coordinates in acceleration–time graph show the area under the velocity–time curve.

In case of Figure 11.10, it is seen that the acceleration line in acceleration–time plot, it shows the variation of acceleration to be uniform.

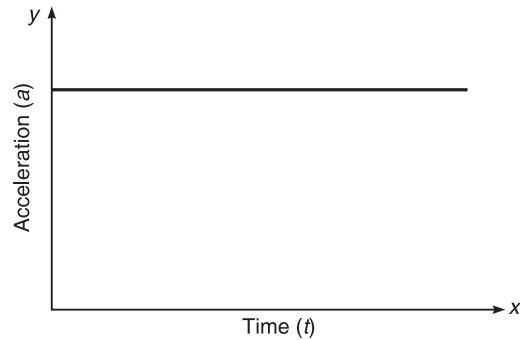
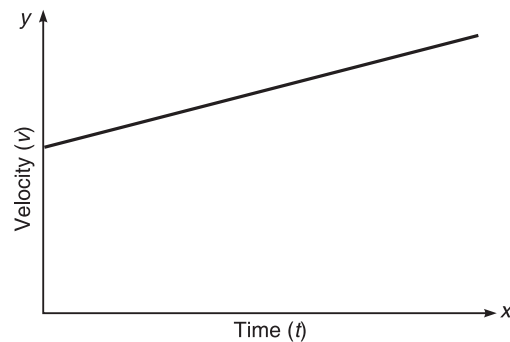
**Figure 11.9** Variation of acceleration with time.**Figure 11.10** Variation of velocity with time.

The curve in velocity–time graph, will be simplified as a straight line in acceleration–time graph.

Using Eqs. (1) and (2), to get an equation without time t , we substitute for t from Eq. 1 in Eq. 2, we get

$$s = u \frac{(v-u)}{a} + \frac{1}{2} \times a \left[\frac{(v-u)}{a} \right]^2 = \frac{u(v-u)}{a} + \frac{(v-u)^2}{2a}$$

$$2as = 2uv - 2u^2 + v^2 + u^2 - 2uv = v^2 - u^2$$

$$v^2 - u^2 = 2as \quad (3)$$

Rectilinear Motion

When a particle or a body moves along a straight line path, then it is called linear motion or rectilinear motion.

Equation of motion along a straight line

$$v = u + at$$

$$v^2 - u^2 = 2as$$

$$s = ut + \frac{1}{2} at^2$$

PROBLEMS ON KINEMATICS

Example 11.1 The motion of a particle is given by the equation $x = t^3 - 3t^2 - 9t + 12$. Determine the time, distance travelled and acceleration of particle when velocity becomes zero.

Solution

$$x = t^3 - 3t^2 - 9t + 12 \quad (1)$$

Differentiating Eq. (1) with respect to 'x', we get

$$v = \frac{dx}{dt} = 3t^2 - 6t - 9 \quad (2)$$

when $v = 0$

$$3t^2 - 6t - 9 = 0$$

The above equation is in the form of

$$ax^2 + bx + c = 0$$

and the solution is

$$x = \frac{-b \pm \sqrt{b^2 - 4ac}}{2a} \quad (3)$$

substituting the respective values in Eq. (3), we get

$$t = -1 \text{ or } t = 3 \text{ s (negative value of } t \text{ can be discarded)}$$

Substitute $t = 3$ s in (1), we get

$$x = -15 \text{ m}$$

Differentiating Eq. (2), we get

$$a = \frac{d^2x}{dt^2} = 6t - 6$$

$$a = 6 \times 3 - 6 = 12 \text{ m/s}^2$$

Example 11.2 The motion of a particle is defined by the relation $x = t^3 - 9t^2 + 24t - 6$. Determine the position, velocity and acceleration when $t = 5$ s.

Solution

$$x = t^3 - 9t^2 + 24t - 6 \quad (1)$$

Differentiating Eq. (1), we get

$$\frac{dx}{dt} = v = 3t^2 - 18t + 24 \quad (2)$$

Differentiating Eq. (2), we get

$$\frac{d^2x}{dt^2} = a = 6t - 18 \quad (3)$$

Substitute $t = 5$ s in Eqs. (1), (2) and (3), we get

$$x = 14 \text{ m}$$

$$v = 9 \text{ m/s}$$

$$a = 12 \text{ m/s}^2$$

Example 11.3 The acceleration of a particle is defined by $a = -2 \text{ m/s}^2$, if $v = 8 \text{ m/s}$ and $x = 0$ when $t = 0$. Determine (i) Velocity (ii) Distance travelled at $t = 6 \text{ s}$.

Solution We know that

$$\begin{aligned} a &= -2 \text{ m/s}^2 \\ a &= \frac{dv}{dt} \\ dv &= a dt \\ dv &= -2dt \end{aligned} \quad (1)$$

Integrating Eq. (1), we get

$$\begin{aligned} v &= -2t + C \\ \text{at } t &= 0, \quad v = 8 \text{ m/s} \\ 8 &= -2 \times 0 + C \\ \therefore C &= 8 \\ v &= -2t + 8 \end{aligned} \quad (2)$$

From (2)

$$\begin{aligned} v &= -2t + 8 \\ \frac{dx}{dt} &= v \\ dx &= v dt \\ dx &= (-2t + 8)dt \end{aligned} \quad (3)$$

Integrating Eq. (2), we get

$$\begin{aligned} x &= \frac{-2t^2}{2} + 8t + K \\ x &= -t^2 + 8t + K \\ \text{at } x &= 0, \quad t = 0, \quad K = 0 \\ x &= -t^2 + 8t \end{aligned} \quad (4)$$

Substitute $t = 6 \text{ s}$ in (2) and (4), we get

$$v = -4 \text{ m/s and } x = 84 \text{ m.}$$

Example 11.4 A driver of a car travelling at a speed of 72 km/h observes the light 300 m ahead of him turning red. The traffic light is timed to remain red for 20 s before it turns to green. If the motorist wishes to pass the light without stopping to wait for it to green. Determine (i) Required uniform acceleration of car (ii) The speed with which the motorist crosses the traffic light.

Solution

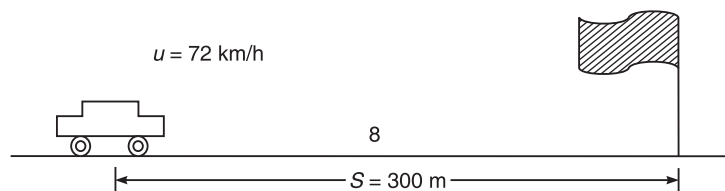

Figure 11.11

(i) *Uniform acceleration:* We know that

$$t = 20 \text{ s}$$

$$u = \frac{72 \times 1000}{60 \times 60} = 20 \text{ m/s}$$

$$\therefore s = ut + \frac{1}{2} at^2$$

$$300 = 20 \times 20 + \frac{1}{2} \times a \times (20)^2$$

$$a = -0.5 \text{ m/s}^2$$

(ii) $v = u + at$

$$v = 20 - 0.5 \times 20 = 10 \text{ m/s}$$

Example 11.5 The motion of a particle along a straight line is defined by the relation $s = 1/3t^3 - 36t$. Find (i) Average acceleration during 4th second (ii) The acceleration when it reverses its direction.

Solution We know that

$$s = \frac{1}{3}t^3 - 36t \quad (1)$$

Differentiating Eq. (1), we get

$$\frac{ds}{dt} = v = \frac{3}{3t^2 - 36}$$

$$v = t^2 - 36 \quad (2)$$

Differentiating Eq. (2), we get

$$a = \frac{dv}{dt} = 2t$$

(i) Average acceleration during 4th second

$$(a)_{t=3 \text{ s}} = 2 \times 3 = 6 \text{ m/s}^2$$

$$(a)_{t=4 \text{ s}} = 2 \times 4 = 8 \text{ m/s}^2$$

Average acceleration during 4th second

$$= \frac{(\text{Acceleration at the end of 3rd second} + \text{Acceleration at the end of 4th second})}{2}$$

$$= \frac{(6 + 8)}{2} = 7 \text{ m/s}^2$$

(ii) Acceleration when it reverse its direction ($v = 0$)

$$\frac{ds}{dt} = 0t^2 = 36, t = 6 \text{ s}$$

$$a = 2 \times 6 = 12 \text{ m/s}^2$$

Example 11.6 A motorist starts with initial velocity takes 10 s to cover a distance of 20 m and 15 s to cover a distance of 40 m. Find the uniform acceleration of car and the velocity at the end of 15 s.

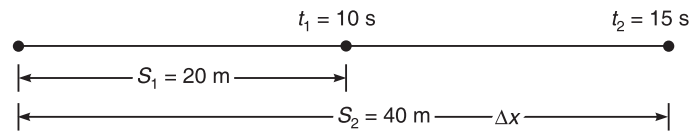

Figure 11.12

Solution We know that $s = ut + \frac{1}{2} at^2$

Distance travelled in 10 s

$$s_1 = 10ut_1 + \frac{1}{2} at_1^2$$

$$20 = 10u + \frac{1}{2} a \times 100$$

$$20 = 10u + 50a \quad (1)$$

Distance travelled in 15 s

$$s_2 = 10ut_2 + \frac{1}{2} at_2^2$$

$$40 = 15u + \frac{1}{2} a \times (15)^2$$

$$40 = 15u + 112.5a \quad (2)$$

From Eqs. (1) and (2), we get

$$a = 0.267 \text{ m/s}^2$$

$$u = 0.664 \text{ m/s}$$

Velocity at the end of 15 s

$$v = u + at$$

$$v = 0.664 + 0.267 \times 15 = 4.669 \text{ m/s}$$

Example 11.7 A body is moving with uniform acceleration and covers 15 m in 5th second and 25 m in 10th second. Determine (i) Initial velocity of body (ii) Acceleration of body.

Solution Distance covered in 5th second = 15 m

Distance covered in 10th second = 25 m

Let, u = initial velocity

a = acceleration

Distance covered in n th second

$$u + \frac{a}{2} (2n - 1) \quad (1)$$

Distance covered in 5th second

$$15 = u + \frac{a}{2}(2 \times 5 - 1)$$

$$15 = u + 4.5a \quad (2)$$

Distance covered in 10th second

$$25 = u + 9.5a \quad (3)$$

By solving Eqs. (2) and (3), we get

$$a = 2 \text{ m/s}^2 \text{ and } u = 1.667 \text{ m/s}$$

Example 11.8 A car is moving with a velocity of 15 m/s. The car is brought to rest by applying brakes in 5 s. Determine (i) Retardation (ii) Distance travelled by the car after applying the brakes.

Solution

(i) Retardation

We know that

$$v = u + at$$

$$0 = 15 + a \times 5$$

$$a = -3 \text{ m/s}^2$$

(ii) Distance travelled by the car after applying the brakes.

We know that

$$s = ut + \frac{1}{2}at^2$$

$$s = 15 \times 5 + \frac{1}{2} \times (-3) \times (5)^2$$

$$s = 37.5 \text{ m}$$

Example 11.9 The acceleration of a particle is defined by the relation $a = (32 - 6t^2)$. The particle starts at $t = 0$ with $v = 0$ and $x = 50$ m. Determine (a) Time when the velocity is again zero (b) Position and velocity when $t = 6$ s (c) The total distance travelled by the particle from $t = 0$ s to $t = 6$ s.

Solution It is given that

$$a = 32 - 6t^2$$

$$\frac{dv}{dt} = 32 - 6t^2$$

$$dv = (32 - 6t^2)dt \quad (1)$$

Integrating Eq. (1), we get

$$v = 32t - \frac{6t^3}{3} + C$$

$$v = 32t - 2t^3 + C$$

at $v = 0$, $t = 0$, $C = 0$

\therefore

$$v = 32t - 2t^3 \quad (2)$$

Again $\frac{dx}{dt} = v$

$$dx = v dt \quad (3)$$

Integrating Eq. (2), we get

$$\int dx = \int (32t - 2t^3) dt$$

$$x = 32t^2 - \frac{2t^4}{4} + K$$

$$x = 32t^2 - 0.5t^4 + K$$

at $t = 0$, $x = 50$ m

$$50 = 0 + 0 + K$$

\therefore

$$K = 50$$

$$x = 32t^2 - 0.5t^4 + 50 \quad (4)$$

(a) The time when the velocity is again zero

Substituting $v = 0$ in Eq. (1), we get

$$(32t - t^3) = 0$$

$$t(32 - t^2) = 0$$

$$t^2 = 32$$

$$t = 5.65 \text{ s}$$

(b) The position and velocity when $t = 6$ s.

$$x = 32(6)^2 - 0.5(6)^4 + 50$$

$$x = 554 \text{ m}$$

$$v = 32 \times 6 - 2(6)^3$$

$$v = 240 \text{ m/s}$$

(c) The total distance travelled by the particle from $t = 0$ s to $t = 6$ s

$$x_0 = 50$$

$$x_6 = 554 \text{ m}$$

$$x_6 - x_0 = 554 - 50 = 504 \text{ m}$$

Example 11.10 A Burglar's car starts an acceleration of 2 m/s^2 . A police vigilant party came after 5 s and continued to chase the Burglar's car with a uniform velocity of 20 m/s . Find the time taken in which the police van will overtake the car.

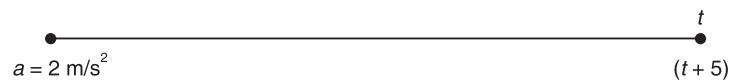

Figure 11.13

Solution Given data:

Acceleration of Burglar's car = 2 m/s^2

Uniform velocity of police party = 20 m/s

Let 't' be the time taken by the police party to overtake the Burglar's car after reaching the spot.

First consider the motion of Burglar's car:

$$u = 0, \quad a = 2 \text{ m/s}^2, \quad t_1 = (t + 5)^2$$

We know that distance travelled by the Burglar's car

$$s = ut + \frac{1}{2} at^2$$

$$s = 0 + \frac{1}{2} \times 2 (t + 5)^2$$

$$s = (t + 5)^2$$

Now consider the motion of police party, velocity = 20 m/s

∴ Distance travelled

$$s = v \times t = 20t$$

For the police party to overtake the car, two distances should be equal

$$\therefore (t + 5)^2 = 20t$$

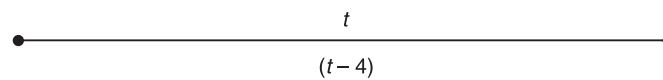

Figure 11.14

$$t = 5 \text{ s}$$

$$s = \frac{1}{2} \times 2t^2 = t^2$$

$$v = \frac{x}{t} = \frac{t-5}{20} = 20(t-5)$$

$$t = 10 \text{ s}, \quad t-5 = 5 \text{ s}$$

$$20t - 100 = t^2$$

$$t^2 - 20t + 100 = 0$$

$$\frac{+20 \pm \sqrt{(20)^2 - 4 \times 1 \times 100}}{2 \times 1} = 10 \text{ s}$$

Example 11.11 The motion of a particle is governed by $a = -8s^{-2}$ when $t = 1 \text{ s}$, $s = 4 \text{ m}$ and $v = 2 \text{ m/s}$. Determine the acceleration of particle at $t = 2 \text{ s}$.

Solution

$$a = -8s^{-2}$$

$$a = \frac{dv}{ds} \times \frac{ds}{dt} = \frac{dv}{vds}$$

∴

$$v dv = -8s^{-2} ds \quad (1)$$

288 ELEMENTS OF CIVIL ENGINEERING AND ENGINEERING MECHANICS

Integrating Eq. (1), we get

$$\frac{v^2}{2} = \frac{-8s^{-2+1}}{-2+1} + C$$

$$\frac{v^2}{2} = \frac{+8s^{-1}}{+1} + C$$

$$\frac{v^2}{2} = 8s^{-1} + C$$

at $v = 2$ m/s; $s = 4$ m

$$\frac{(2)^2}{2} = 8(4)^{-1} + C$$

∴

$$C = 0$$

$$v^2 = 16s^{-1}$$

$$v = \sqrt{16s^{-1}} = 4\sqrt{s^{-1}}$$

$$v = 4\sqrt{s^{-1}} \quad (2)$$

$$\frac{ds}{dt} = v = 4\sqrt{s^{-1}}$$

$$\frac{ds}{dt} = 4\sqrt{s^{-1}}$$

$$\frac{1}{\sqrt{s^{-1}}} ds = 4dt$$

$$\sqrt{s} ds = 4dt \quad (3)$$

$$\int \sqrt{s} ds = \int 4dt$$

$$\int s^{1/2} ds = \int 4dt$$

$$\frac{2s^{3/2}}{3} = 4t + K$$

at $s = 4$, $t = 1$

$$\frac{2(4)^{3/2}}{3} = 4 \times 1 + K$$

$$\frac{2s^{3/2}}{3} = 4t + 1.33$$

$$\begin{aligned}
 0.665^{3/2} &= 4t + 1.33 \\
 s^{3/2} &= 6t + 2 \\
 s &= (6t + 2)^{2/3} \quad (4)
 \end{aligned}$$

Differentiating Eq. (1) with respect to t , we get

$$v = \frac{ds}{dt} = \frac{2}{3} (6t + 2)^{-1/3} \quad (5)$$

Again differentiating Eq. (5), we get

$$\begin{aligned}
 a &= \frac{dv}{dt} = \frac{2}{3} (6t + 2)^{-1/3} \times 6 \\
 &= \frac{-1}{3} \times 4(6t + 2) \\
 a &= -8(6t + 2)^{-4/3} \\
 (a)_{t=2} &= -8(6t + 2)^{-4/3} \\
 a &= 0.264 \text{ m/s}^2
 \end{aligned}$$

Example 11.12 A car and truck are both travelling at a constant speed of 45 km/h. Car is 10 m behind the truck. The truck driver suddenly applies his brakes, causing the truck to decelerate at a constant rate at 2 m/s^2 . Two seconds later the driver of car applied his brakes and just manages to avoid rear end collision. Determine the constant rate at which the car decelerated.

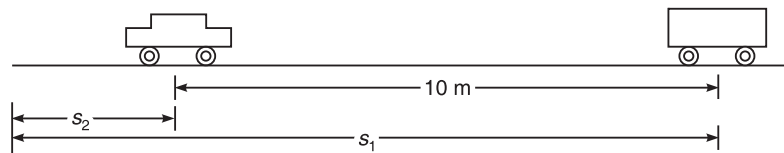

Figure 11.15

Solution Consider both car and truck are moving with a speed of 45 km/h at any time ' t '

Consider a car:

$$s_2 - s_1 = 10$$

Consider a truck:

$$v = u + at$$

$$0 = 12.5 - 2 \times t$$

$$t = 6.25 \text{ s}$$

$$s_2 = ut + \frac{1}{2} at^2$$

$$= 12.5 \times 6.25 - \frac{1}{2} \times 2(6.25)^2$$

$$s_2 = 39.06 \text{ m}$$

290 ELEMENTS OF CIVIL ENGINEERING AND ENGINEERING MECHANICS

Consider car:

$$(s_2 - 10) = u(t + 2) + \frac{1}{2} a(t + 2)^2$$

$$(39.06 - 10) = 12.5(6.25 + 2) + \frac{1}{2} a(8.25)^2$$

$$29.06 = 103.125 + 34.03a$$

$$a = -2.17 \text{ m/s}^2$$

MOTION UNDER GRAVITY

We know that every body on the earth experiences a force of attraction towards the centre of the earth is known as gravity. When a body is allowed to fall freely, it is acted upon by acceleration due to gravity and its velocity goes on increasing until it reaches the ground. The force of attraction of the earth that pulls all bodies towards the centre of earth with uniform acceleration is known as acceleration due to gravity. The value of acceleration due to gravity is constant in general and its value is considered to be 9.81 m/s^2 and is always directed towards the centre of earth. Acceleration due to gravity is generally denoted by 'g'.

When the body is moving vertically downwards, the value of g is considered as positive and if the body is projected vertically upwards, then acceleration due to gravity is considered as negative. Evidently, all equations of motion are applicable except by replacing uniform acceleration 'a' with acceleration due to gravity 'g' and are written as

- (i) When a body is projected vertically downward, under the action of gravity, the equations of motion are

$$v = u + gt$$

$$v^2 = u^2 + 2gh$$

$$h = ut + \frac{1}{2} gt^2$$

- (ii) When a body is projected vertically upward, under the action of gravity, the equations of motion are

$$v = u - gt$$

$$v^2 = u^2 - 2gh$$

$$h = ut - \frac{1}{2} gt^2$$

Example 11.13 A ball is thrown vertically upward into air with an initial velocity of 35 m/s. After 3 s another ball is thrown vertically. What initial velocity must be the second ball has to pass the first ball at 30 m from the ground.

Solution Consider the first ball, we know that

$$h = u_1 t - \frac{1}{2} gt^2$$

$$30 = 35t - \frac{1}{2} \times 9.81t^2$$

$$4.905t^2 - 35t + 30 = 0$$

$$t^2 - 7.135t + 6.116 = 0$$

$$x = \frac{+7.135 \pm \sqrt{(7.135)^2 - 4 \times 1 \times 6.116}}{2 \times 1}$$

$$x = \frac{7.135 \pm 5.142}{2} = 6.138 \text{ s and } 0.9965 \text{ s}$$

$$t = 6.138 \text{ s}$$

Consider the second ball

$$t_2 = (6.138 - 3) = 3.138 \text{ s}$$

$$h = u_2 t_2 - \frac{1}{2} g t_2^2$$

$$30 = u_2 \times 3.138 - \frac{1}{2} \times 9.81 \times (3.138)^2$$

$$30 = 3.138 u_2 - 48.30$$

$$u_2 = 24.91 \text{ m/s}$$

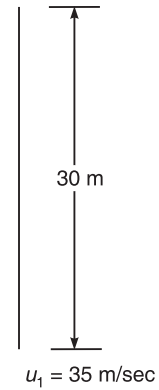

Figure 11.16

Example 11.14 A stone is dropped into a well and a sound of splash is heard after 4 s. Find the depth of well if the velocity of sound is 350 m/s.

Solution Let 'h' be the depth of the well, we have

$$t_1 + t_2 = 4 \text{ s} \quad (1)$$

Let, $t_1 \rightarrow$ Time taken by the stone to reach bottom of well

$t_2 \rightarrow$ Time taken by the sound to reach top of the well

Consider the motion of the stone:

Using equation

$$h = ut + \frac{1}{2} g t^2$$

$$h = ut + \frac{1}{2} g t^2$$

where $u = 0$, $t = t_1$, $g = 9.81 \text{ m/s}^2$

Therefore,

$$h = 0 + \frac{1}{2} 9.81 \times t_1^2$$

$$h = 4.905 t_1^2 \quad (2)$$

Consider the motion of the sound:

Let 'v' be the velocity of sound

t_2 be the time

292 ELEMENTS OF CIVIL ENGINEERING AND ENGINEERING MECHANICS

$$v = \frac{h}{t_2}$$

$$t_2 = \frac{h}{v_2}$$

$$t_2 = \frac{4.905t_1^2}{350} = 0.014t_1^2$$

Substituting in Eq. (1), we get

$$t_1 + 0.014t_1^2 = 4$$

$$t_1^2 + 71.428t_1 - 285.71$$

$$t = \frac{-71.428 \pm \sqrt{(71.428)^2 + 4 \times 1 \times 285.71}}{2 \times 1}$$

$$t = \frac{-71.428 \pm 79.024}{2}$$

$$t_1 = 3.798 \text{ s}$$

$$\therefore h = 4.905 \times (3.798)^2$$

$$h = 70.75 \text{ m}$$

Example 11.15 A stone is dropped from the top of the tower 50 m high. At the same time another stone is thrown up from the foot of the tower with a velocity of 25 m/s. At what distance from the top and after how much time the two stones cross each other.

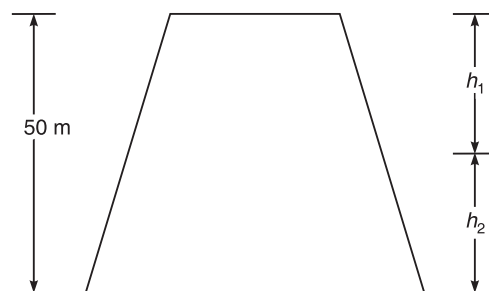

Figure 11.17

Solution Condition for the two stones to cross each other is

$$h_1 + h_2 = 50 \quad (1)$$

Consider the first stone:

$$u = 0, h = h_1, g = +9.81 \text{ m/s}^2$$

$$h = ut + \frac{1}{2}g \times t^2$$

$$h_1 = 0 + \frac{1}{2}9.81 \times t^2$$

$$h_1 = 4.905t^2$$

Consider the second stone:

$$u = 25 \text{ m/s}, h = h_2, g = -9.81 \text{ m/s}^2$$

$$\therefore h = ut + \frac{1}{2}g \times t^2$$

$$h_2 = 25t - \frac{1}{2}9.81 \times t^2 = 25t - 4.905t^2$$

Substitute h_1 and h_2 in Eq. (1), we get

$$25t = 50$$

$$t = 2 \text{ s}$$

$$\therefore h_1 = 4.905 (2)^2 = 19.6 \text{ m}$$

Example 11.16 A stone is thrown vertically upward from the top of tower 20 m high with a velocity of 15 m/s. Find (i) The highest elevation reached by the stone (ii) The time required for the stone to cross the top of tower during its downward motion and corresponding velocity.

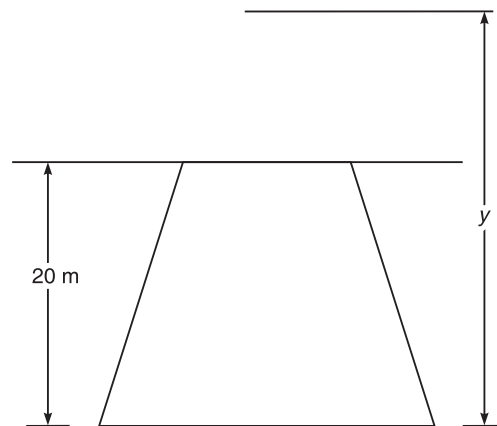

Figure 11.18

Solution Consider the general equation of motion of particle at any time 't' after its throw. The distance will be considered from the ground as a reference.

We know that

$$\frac{dv}{dt} = a = -g = -9.81 \text{ m/s}^2$$

or

$$dv = -9.81 dt \quad (1)$$

294 ELEMENTS OF CIVIL ENGINEERING AND ENGINEERING MECHANICS

Integrating Eq. (1)

$$\int_{15}^v dv = \int_0^t -9.81 dt$$

$$[v]_{15}^v = [-9.81t]_0^t$$

$$v - 15 = -9.81t$$

$$v = -9.81t + 15 \quad (2)$$

We know that

$$v = \frac{dy}{dt} = -9.81t + 15$$

$$dy = (-9.81t + 15)dt \quad (3)$$

Integrating (3)

$$\int_{20}^y dy = \int_0^t (-9.81t + 15)dt$$

$$y = \left[15t - \frac{9.81t^2}{2} \right]_0^t$$

$$y = 15t - 4.9t^2 + 20 \quad (4)$$

(i) When stone reaches highest elevation $v = 0$

$$t = 1.53 \text{ s}$$

$$\therefore y = 31.5 \text{ m from ground}$$

(ii) $y = 30 \text{ m}$ when stone crosses the top of tower

$$\therefore t = \frac{15}{4.9}$$

$$\therefore t = 3.06 \text{ s}$$

Example 11.17 A ball is tossed with a velocity of 10 m/s directed vertically upward from a window located 20 m above the ground. If the acceleration of ball is constant and equal to 9.81 m/s², determine (a) the velocity v and elevation y of the ball above the ground at any time t .

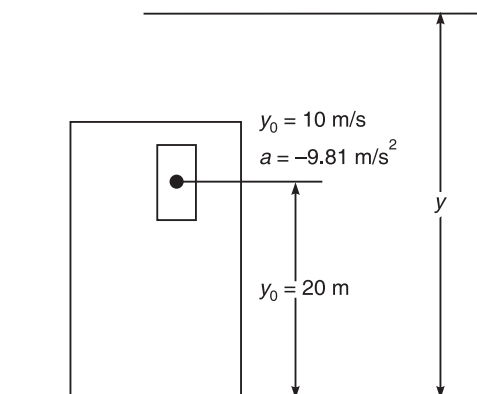

Figure 11.19

Solution

$$(a) \quad a = \frac{dv}{dt}$$

$$\int_{10}^y dv = \int_0^t -9.81 dt$$

$$v - 10 = -9.81t$$

$$v = -9.81t + 10 \quad (1)$$

Again $\frac{dy}{dt} = v$

$$dy = (10 - 9.81t) dt$$

$$\int_{20}^y dy = \int_0^t (10 - 9.81t) dt$$

$$= (y - 20) = 10t - \frac{9.81t^2}{2}$$

$$y = 20 + 10t - 4.905t^2 \quad (2)$$

Example 11.18 A stone is thrown vertically into the air from the top of tower 100 m high. At the same instant a second stone is thrown upward from the ground. The initial velocity of first stone is 50 m/s and that of second stone is 75 m/s. When and where will the stones be at the same height from the ground.

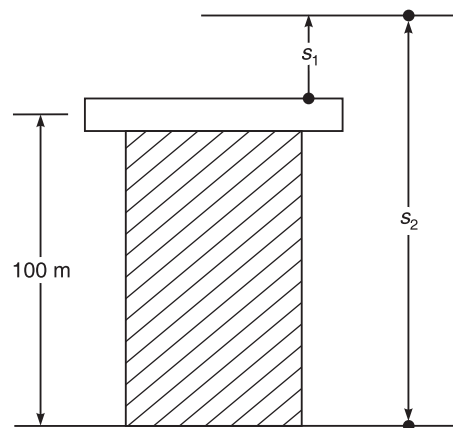

Figure 11.20

Solution Consider the first stone:

$$u_1 = 50 \text{ m/s}, \quad g = -9.81 \text{ m/s}^2$$

$$s_1 = u_1 t + \frac{1}{2} g t^2$$

$$s_1 = 50t - 4.905t^2 \quad (1)$$

Consider the second stone:

$$u_2 = 75 \text{ m/s}, \quad g = -9.81 \text{ m/s}^2$$

$$s_2 = u_2 t + \frac{1}{2} g t^2$$

$$s_2 = 75t - 4.905t^2 \quad (2)$$

$$s_2 - s_1 = 100 = (75t - 4.905t^2) - (50t - 4.905t^2)$$

$$100 = 25t$$

$$t = 4 \text{ s}$$

$$s_2 = 75 \times 4 - 4.905(4)^2 = 221.52 \text{ m}$$

$$s_1 = 50 \times 4 - 4.905(4)^2 = 121.52 \text{ m}$$

CURVILINEAR MOTION

Introduction

When a moving particle describes a path other than a straight line is said to be a particle in curvilinear motion. If the curved path lies in a single plane is called plane curvilinear motion. Most of the motions of particles encountered in engineering practices are of this type.

Curvilinear Motion in Cartesian Coordinates

In Cartesian coordinates two axes of reference will be chosen. To define the position of particle at any instant of time we have to choose a reference axis namely x and y .

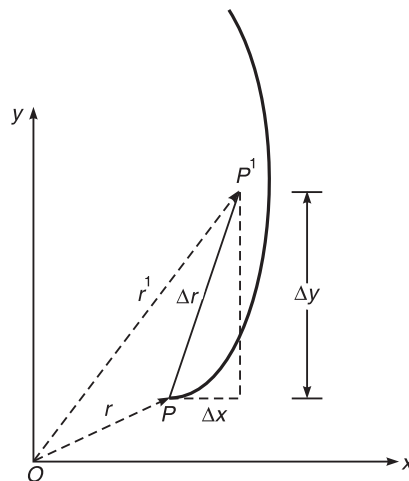

Figure 11.21

Let, P be the position of particle at any instant of time ' t '

' P^1 ' be the new position at an instant of time $(t + \Delta t)$ from origin.

Join O to P and O to P^1

Let ' r ' be the position vector of P having magnitude and direction.

r^1 be the position vector P^1

Δr be the rate of change in displacement amount over a time Δt

$$\therefore \text{Average velocity over a time } \Delta t = \frac{\Delta r}{\Delta t}$$

Velocity of particle is 'vector tangent to the path of particle'

Let, ' Δx ' be the distance travelled in x direction

' Δy ' be the distance travelled in y direction

$$\text{Velocity in 'x' direction} = v_x = \frac{dx}{dt}$$

$$\text{Velocity in 'y' direction} = v_y = \frac{dy}{dt}$$

$$\therefore \text{Resultant velocity} = v = \sqrt{v_x^2 + v_y^2}$$

Normal and tangential component of acceleration: Velocity of moving particle is always vector tangential to the path of particle. But acceleration is not tangential to path. But it is convenient to resolve the acceleration along tangential and normal direction.

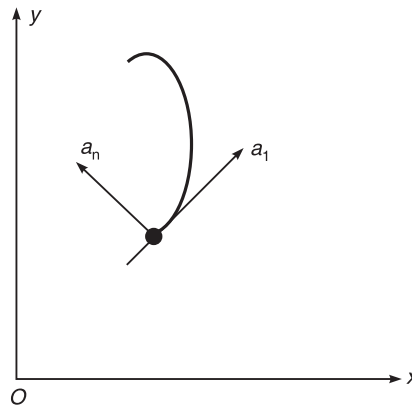

Figure 11.22

$$\therefore \text{Tangential acceleration} = a_t = \frac{dv}{dt}$$

$$\text{Normal acceleration} = a_n = \frac{v^2}{\rho} = r$$

Where ' ρ ' is the radius of curvature.

298 ELEMENTS OF CIVIL ENGINEERING AND ENGINEERING MECHANICS

From the above expression it is evident that tangential component of acceleration is equal to the rate of change of velocity with respect to time. Normal component of acceleration is equal to the square of velocity divided by the radius of curvature.

Example 11.19 The motion of a particle is described by the following equation $x = 2(t + 1)^2$, $y = 2(t + 1)^{-2}$. Show that path travelled by the particle is rectangular hyperbola. Also find the velocity and acceleration of particle at $t = 0$.

Solution To find the path travelled, we know that

$$x = 2(t + 1)^2 \quad (1)$$

$$y = 2(t + 1)^{-2} \quad (2)$$

Multiplying the two equation

$$xy = 2 \quad [\because xy = \text{constant}]$$

This represents a rectangular hyperbola

We know $x = 2(t + 1)^2$

Component of velocity in x direction $v_x = 2 \times 2(t + 1)$

Component of acceleration in x direction $a_x = \frac{d^2x}{dt^2} = 2 \times 2 = 4 \text{ m/s}^2$

When $t = 0$,

$$v_x = 4 \text{ m/s}^2$$

$$a_x = 4 \text{ m/s}^2$$

We know $y = 2(t + 1)^{-2} = \frac{2}{(t + 1)^2}$

Component of velocity in y direction

$$v_y = \frac{dy}{dt} = 2(-2)(t + 1)^{-3}$$

$$= -4(t + 1)^{-3}$$

Component of acceleration in y direction

$$a_y = \frac{d^2y}{dt^2} = (-4)(-3)(t + 1)^{-4} = -12(t + 1)^{-4}$$

When $t = 0$

$$v_y = -4(0 + 1)^{-3} = -4 \text{ m/s}$$

$$a_y = -12(0 + 1)^{-4} = +12 \text{ m/s}^2$$

$$\text{Velocity} = v = \sqrt{v_x^2 + v_y^2} = \sqrt{4^2 + (-4)^2}$$

$$\tan \theta = \frac{v_y}{v_x} = \frac{-4}{4} \theta = \tan^{-1}(-1) = -45^\circ$$

$$\text{Acceleration} = a = \sqrt{a_x^2 + a_y^2} = \sqrt{4^2 + (12)^2} = 12.65 \text{ m/s}^2$$

$$\alpha = \tan^{-1} \frac{12}{4} = 71.6^\circ$$

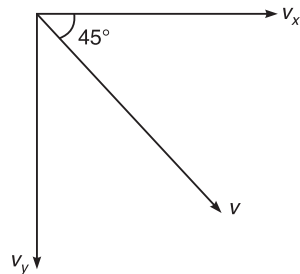

Figure 11.23

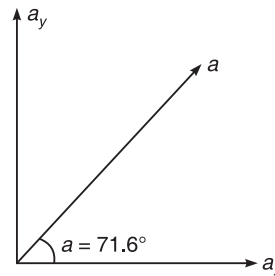

Figure 11.24

Example 11.20 A motorist travelling on a curved road of radius 200 m at a speed of 72 km/h. Find the normal and tangential components at acceleration.

He applies brakes to slow down his car uniformly to a speed of 36 km/h in 10 s. Find normal and tangential components of acceleration just after brakes are applied.

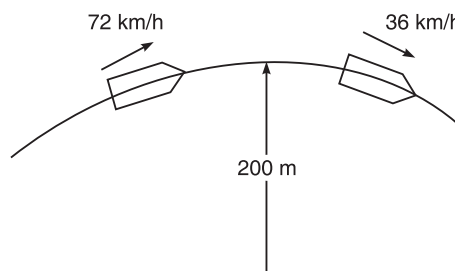

Figure 11.25

Solution

(i) When travelling at a constant speed

$$a_t = \frac{dv}{dt} = 0$$

$$a_n = \frac{v^2}{\rho} = \frac{(20)^2}{200} = 2 \text{ m/s}^2$$

(ii) At the instant when the brakes are applied the car has tangential speed of 20 m/s in addition experiences a tangential acceleration.

$$a_t = \frac{dv}{dt} = \frac{20 - 10}{10 - 0} = \frac{10}{10} = 1 \text{ m/s}^2$$

$$a_n = \frac{v^2}{\rho} = \frac{(20)^2}{200} = 2 \text{ m/s}^2$$

Normal component is constant.

300 ELEMENTS OF CIVIL ENGINEERING AND ENGINEERING MECHANICS

Example 11.21 Distance covered by particle travelling are a curved path and starting from rest is given by the equation $s = Kt^2$. Find the tangential and normal components of acceleration of particle.

Solution

$$s = Kt^2$$

$$v = \frac{ds}{dt} = 2Kt$$

$$a = \frac{dv}{dt} = 2K$$

$$\text{Tangential acceleration} = a_t = \frac{dv}{dt} = 2K$$

$$\text{Normal acceleration} = a_n = \frac{v^2}{\rho} = \frac{4K^2t^2}{r}.$$

Example 11.22 The particle moves along a curve of characteristic $x = 0.65y^2$. Its value of motion is $x = 4t^2$ at the instant when $t = 3$ s determine (i) The displacement of particle from origin (ii) The velocity of particle (iii) The acceleration of particle.

Solution Equation of curve is $x = 0.65y^2$

(i) The displacement of particle from origin at the instant $t = 3$ s

$$x = 4(3)^2 = 36 \text{ m}$$

$$y = \sqrt{\frac{x}{0.65}} = \sqrt{\frac{36}{0.65}} = 7.44 \text{ m}$$

$$x = 36 \text{ m} \quad \text{and} \quad y = 7.44 \text{ m}$$

$$s = \sqrt{x^2 + y^2} = 36.76 \text{ m}$$

(ii) The velocity of particle

$$x = 4t^2$$

$$v_x = \frac{dx}{dt} = 8t$$

$$4t^2 = 0.65y^2$$

$$y^2 = \frac{4t^2}{0.65}$$

$$y = 2.48t$$

$$v_y = \frac{dy}{dt} = 2.48$$

$$v = \sqrt{v_x^2 + v_y^2} = 24.13 \text{ m/s}$$

(iii) The acceleration of particle $a_x = 8 \text{ m/s}^2$

$$a = \sqrt{(8)^2 + 0} = 8 \text{ m/s}^2$$

Example 11.23 A car is travelling on a curved section of a track of radius 1000 m at a speed of 100 km/h. The brakes are suddenly applied causing the car to slow down at constant rate. After 10 s the speed of car is reduced to 60 km/h. Determine the acceleration of car immediately after the brakes are applied.

Solution

$$u = 100 \text{ km/h} = 27.78 \text{ m/s}$$

$$v = 60 \text{ km/h} = 16.67 \text{ m/s}$$

$$t = 10 \text{ s}$$

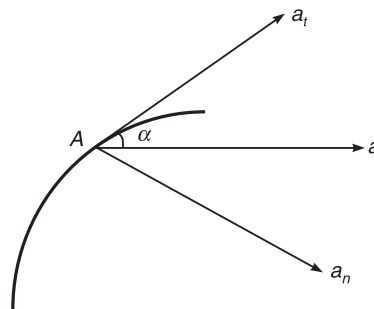

Figure 11.26

Using relation

$$\text{Tangential acceleration} = a_t = \frac{dv}{dt} = \frac{16.67 - 27.78}{10} = -1.11 \text{ m/s}^2$$

' a_t ' remains constant throughout and is negative due to retardation.

Velocity of car immediately after the brakes are applied = $v = 27.78 \text{ m/s}$

$$\text{Normal component of acceleration } a_n = \frac{v^2}{\rho} = \frac{(27.78)^2}{1000} = 0.772 \text{ m/s}^2$$

$$\text{Resultant acceleration} = a = \sqrt{a_t^2 + a_n^2}$$

$$a = \sqrt{(1.11)^2 + (0.772)^2} = 1.352 \text{ m/s}^2$$

$$\alpha = [\tan^{-1}] \left(\frac{a_n}{a_t} \right) = 34.82^\circ$$

Example 11.24 A car starts from rest on a curve of radius 250 m and accelerates at constant tangential acceleration $a_t = 1.2 \text{ m/s}^2$. Determine the distance travelled and time taken when the magnitude of total acceleration is 1.5 m/s^2 .

Solution

$$v = 0, \rho = R = 250 \text{ m}, a_t = 1.2 \text{ m/s}^2, a = 1.5 \text{ m/s}^2$$

$$\text{We know total acceleration} = a = \sqrt{a_t^2 + a_n^2}$$

$$(1.5) = \sqrt{(1.2)^2 + a_n^2}$$

$$a_n = 0.9 \text{ m/s}^2$$

We know

$$a_n = \frac{v^2}{\rho}$$

$$v^2 = a_n \times \rho = 0.9 \times 250 = 225$$

$$v = 15 \text{ m/s}^2$$

$$v = u + a_t t$$

$$15 = 0 + 1.2 \times t$$

$$t = 12.5 \text{ s}$$

Again,

$$v^2 = u^2 + 2a_t s$$

$$(15)^2 = 0 + 2 \times 1.2 \times s$$

$$s = 93.75 \text{ m}$$

$$a_t = 1.2 \text{ m/s}^2, a_n = 0.9 \text{ m/s}^2, s = 93.75 \text{ m}, t = 12.5 \text{ s}$$

Example 11.25 An automobile enters a curved road in the form of quarter of a circle and at length 360 m at a speed of 24 km/h and then leaves the curve at 48 km/h. (If the car is travelling at constant acceleration along the curve.) Determine the resultant acceleration at both the ends of curve.

Solution The curve is in the form of quarter circle and of length 360 m = 0.36 km

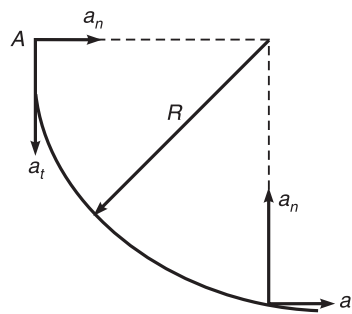

Figure 11.27

$$0.36 = \frac{1}{4} \times 2\pi r$$

$$r = 0.2293 \text{ km}$$

Hence radius of curvature = 0.2293 km

Velocity at A = $v_A = 24 \text{ km/h}$

$B = v_B = 48 \text{ km/h}$

$$v^2 = u^2 + 2as$$

$$(48)^2 = (24)^2 + 2a_t(0.36)$$

$$a_t = 2400 \text{ km/h}^2$$

Normal component of acceleration at A is $a_n = \frac{v_a^2}{\rho} = \frac{(48)^2}{(0.2293)} = 2512 \text{ km/h}^2$

Resultant acceleration = $a = \sqrt{(a_n)^2 + a_t^2}$

$$a = \sqrt{(2400)^2 + (2512)^2} = 3474 \text{ km/h}^2$$

$$\alpha = \tan^{-1}\left(\frac{2512}{2400}\right) = 46.30^\circ$$

Normal component of acceleration at B is $a_n = \frac{v_B^2}{\rho} = \frac{(48)^2}{(0.2293)} = 10048 \text{ km/h}^2$

Resultant acceleration = $a = \sqrt{(a_n)^2 + (a_t)^2}$

$$= 10330.6 \text{ km/h}^2.$$

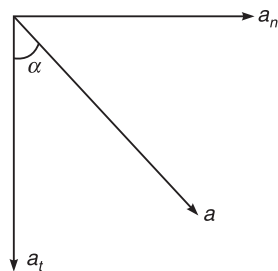

Acceleration at A

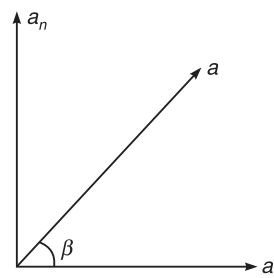
Figure 11.28

Acceleration at B

Figure 11.29

Example 11.26 A rotor 25 mm in diameter is spinning at 200 rps. Find the normal component of acceleration of a point on the rim.

Solution

Diameter = 25 mm, $R = 12.5$ mm, Angular velocity = $\omega = 200$ rps

But,

$$1 \text{ rps} = (2\pi) \text{ rad/s}, \omega = (200) (2\pi) \text{ rad/s} = 1256.64 \text{ rad/s}$$

Linear velocity = Radius \times Angular velocity

$$v = 12.5 \times 1256.64 = 15708 \text{ mm/s}$$

$$a_n = \frac{v^2}{\rho} = \frac{15708^2}{12.5} = 1.97 \times 10^7 \text{ mm/s}^2$$

$$a_n = 19700 \text{ m/s}^2$$

304 ELEMENTS OF CIVIL ENGINEERING AND ENGINEERING MECHANICS

Example 11.27 The motion of particle is described by the following equations

$$x = t^2 + 8t + 4$$

$$y = t^3 + 3t^2 + 8t + 4$$

Determine (i) Initial velocity of the particle, (ii) Velocity of particle at 2 s, (iii) Acceleration of particle at $t = 2$ s.

Solution

$$v_x = \frac{dx}{dt} = 2t + 8$$

$$v_y = \frac{dy}{dt} = 3t^2 + 6t + 8$$

$$a_x = \frac{dv_x}{dt} = 2$$

$$a_y = \frac{dv_y}{dt} = 6t + 6$$

(i) Initial velocity: when $t = 0$

$$v_x = 0 + 8 = 8 \text{ m/s}$$

$$v_y = 0 + 0 + 8 = 8 \text{ m/s}$$

$$\theta = \tan^{-1} \left(\frac{v_y}{v_x} \right) = 45^\circ$$

(ii) Velocity at $t = 2$ s

$$v_x = 2(2) + 8 = 12 \text{ m/s}$$

$$v_y = 3(2)^2 + 6(2) + 8 = 32 \text{ m/s}$$

$$v = \sqrt{(12)^2 + (32)^2} = 34.176 \text{ m/s}$$

(iii) Acceleration at $t = 2$ s

$$a_x = 2 \text{ m/s}^2$$

$$a_y = 18 \text{ m/s}^2$$

$$a = \sqrt{(2)^2 + (18)^2} = 18.11 \text{ m/s}^2$$

Example 11.28 A train starting from rest is moving along a curved track with a constant acceleration and attains a speed of 60 km/h in 3 minutes. Determine the acceleration of train 1 minute after leaving the station. The radius of curvature of track is 800 m.

Solution

$$a_t = \frac{dv}{dt} = \frac{16.66 - 0}{180 - 0} = 0.0925 \text{ m/s}^2$$

Velocity at $t = 60$ s

$$v = u + a_t t$$

 \therefore

$$v = 0 + 0.0925 \times 60 = 5.55 \text{ m/s}$$

 \therefore

$$a_n = \frac{v^2}{\rho} = \frac{(5.55)^2}{800} = 0.0385 \text{ m/s}^2$$

$$a = \sqrt{(0.0925)^2 + (0.0385)^2} = 0.100 \text{ m/s}^2$$

Example 11.29 A car starts from rest on a curved road of 250 m radius and accelerates at a constant tangential acceleration of 0.6 m/s^2 . Determine the distance and time for which that car will travel before the magnitude of total acceleration attained by it becomes 0.75 m/s^2 .

Solution

$$a = 0.75 \text{ m/s}^2$$

$$a_t = 0.6 \text{ m/s}^2$$

$$a = \sqrt{a_t^2 + a_n^2}$$

$$a_n = \sqrt{a^2 - a_t^2}$$

$$a_n = 0.45 \text{ m/s}^2$$

We know

$$a_n = \frac{v^2}{\rho} = 0.45$$

$$v = \sqrt{250 \times 0.45} = 10.6 \text{ m/s}$$

Using

$$v = u + a_t t$$

$$10.6 = 0 + 0.6 \times t$$

 \therefore

$$t = 17.68 \text{ s}$$

Using $v^2 - u^2 = 2as$

$$s = \frac{v^2}{2a} = \frac{(10.6)^2}{2 \times 0.6}$$

 \therefore

$$s = 93.93 \text{ m}$$

Example 11.30 A particle starting from the origin is subjected to acceleration such that $a_x = -3.0 \text{ m/s}^2$ and $a_y = -11.0 \text{ m/s}^2$. If the initial velocity is 80 m/s directed at a slope of 4:3 as shown in Figure 11.30. Compute the radius of curvature of path after 4 s and also find the position at the end of 4 s.

Solution The components of initial velocity = $v_0 = 80 \text{ m/s}$ (at $t = 0$ s)

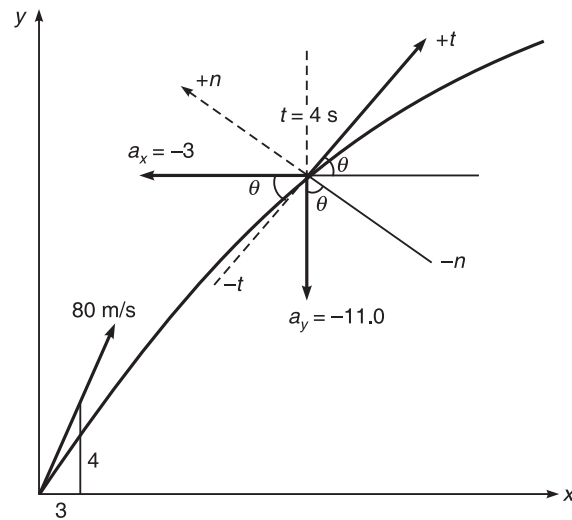

Figure 11.30

$$v_{0x} = v_0 \cos \theta = 80 \times \frac{3}{5} = 48 \text{ m/s}$$

$$v_{0y} = v_0 \sin \theta = 80 \times \frac{4}{5} = 64 \text{ m/s}$$

Velocity component at $t = 4$ s are $v = u_x + a_x t$

$$v = \sqrt{v_{0x}^2 + v_{4x}^2}$$

$$v_{4x} = 48 - 3(4) = +36.0 \text{ m/s}$$

$$v_{4y} = 64 - 11(4) = +20.0 \text{ m/s}$$

Inclination with x axis

$$\theta = \tan^{-1} \left(\frac{v_{4y}}{v_{4x}} \right) = \tan^{-1} \left(\frac{20}{36} \right) = 32^\circ$$

This gives the inclination of tangent (velocity) with x axis $\theta = 32^\circ$

$$a_n = a_y \cos \theta - a_x \sin \theta$$

$$a_n = -(-11.0) \cos 32 - 3 \sin 32 = 8.19 \text{ m/s}^2$$

Since

$$a_n = \frac{v_4^2}{\rho_4}$$

$$\therefore \rho_4 = \frac{v_4^2}{a_n} = \frac{(36)^2 + (20)^2}{8.19} = 207.08 \text{ m}$$

\therefore Radius of curvature = 207.08 m

Position at $t = 4$ s

$$x_4 = u_x t_4 + \frac{1}{2} a_x t_4^2 = 48 \times 4 + \frac{1}{2} \times (-3)(4)^2 = 168 \text{ m}$$

$$y_4 = u_y t_4 + \frac{1}{2} a_y t_4^2 = 64 \times 4 + \frac{1}{2} \times (-11.6)(4)^2 = 168 \text{ m}$$

\therefore $P(168, 168)$

Example 11.31 A particle moves in such a way that $a_x = 2 \text{ m/s}^2$ and $a_y = 10 \text{ m/s}^2$ where a_x and a_y are the components of acceleration in x and y direction. If its initial velocity is 32 m/s directed at the slope of $\tan^{-1}(4/3)$ with x direction. Compute the radius of curvature of its path in 2 s .

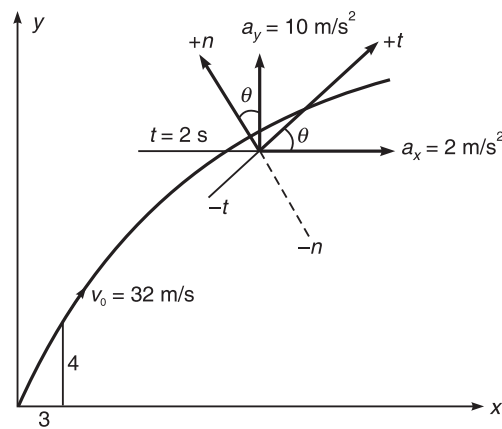

Figure 11.31

Solution at $t = 0$

Components of velocity

$$v_{0x} = v_0 \cos \theta = 32 \times \frac{3}{5} = 19.2 \text{ m/s}$$

$$v_{0y} = v_0 \sin \theta = 32 \times \frac{4}{5} = 25.6 \text{ m/s}$$

at $t = 2 \text{ s}$

$$v_{4x} = v_{0x} + a_x t = 19.2 + 2 \times 2 = 23.2 \text{ m/s}$$

$$v_{4y} = v_{0y} + a_y t = 25.6 + 10 \times 2 = 45.6 \text{ m/s}$$

$$v = \sqrt{(23.2)^2 + (45.6)^2} = 68.53$$

$$\theta = \tan^{-1} \left(\frac{45.6}{23.2} \right) = 63.03^\circ$$

$$a_n = a_y \cos \theta - a_x \sin \theta$$

$$a_n = 10 \cos 63.03 - 2 \sin 63.03 = 2.7 \text{ m/s}^2$$

$$a_n = \frac{v^2}{\rho}$$

$$\therefore \rho = \frac{v^2}{a_n} = \frac{(68.53)^2}{27} = 950.00 \text{ m/s}^2$$

Example 11.32 A particle starting from origin with initial velocity of 60 m/s directed at a slope of 3/4 to x -axis moves with acceleration $a_x = -4 \text{ m/s}^2$ and $a_y = -7 \text{ m/s}^2$ locate the position of particle after 5 s. Also find its normal and tangential acceleration at that instant. What is the radius of curvature of its path at that instant?

Solution The components of initial velocity: at $t = 0$

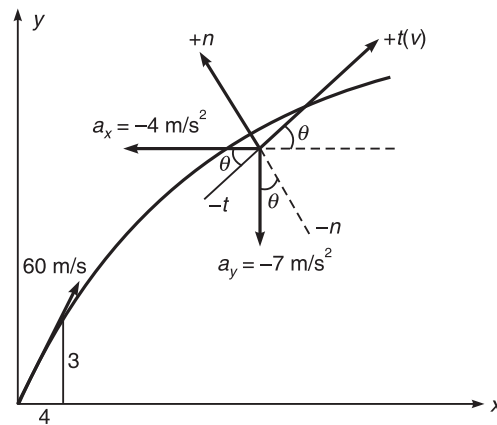

Figure 11.32

$$v_{0x} = v_0 \cos \theta = 60 \times \frac{4}{5} = 48 \text{ m/s}$$

$$v_{0y} = v_0 \sin \theta = 60 \times \frac{3}{5} = 36 \text{ m/s}$$

The components of velocity at $t = 5 \text{ s}$

$$\begin{aligned} v_x &= u_x + a_x t \\ &= 48 - 4 \times 5 = 28 \text{ m/s} \end{aligned}$$

$$\begin{aligned} v_y &= u_y + a_y t \\ &= 36 - 7 \times 5 = 1 \text{ m/s} \end{aligned}$$

$$v = \sqrt{(28)^2 + (1)^2} = 28.01 \text{ m/s}$$

$$\theta = \tan^{-1} \left(\frac{1}{28} \right) = 2.045^\circ$$

Normal acceleration

$$\begin{aligned} a_n &= a_x \sin \theta - a_y \cos \theta \\ a_n &= -4 \sin 2.045^\circ - (-7) \cos 2.045^\circ \\ &= -0.142 + 6.995 \\ a_n &= 6.853 \text{ m/s}^2 \end{aligned}$$

Radius of curvature

$$\begin{aligned} \frac{a_n}{1} &= \frac{v^2}{\rho} \\ v^2 &= a_n \rho \\ \rho &= \frac{v^2}{a_n} = \frac{(28.01)^2}{6.853} = 114.48 \text{ m} \\ a_t &= -a_x \cos \theta - a_y \sin \theta \\ a_t &= -(-4) \cos 2.045^\circ - (-7) \sin 2.045^\circ \\ &= 3.997 + 0.249 \\ a_t &= 4.246 \text{ m/s}^2 \end{aligned}$$

Position (at $t = 5$ s)

$$\begin{aligned} x_5 &= u_x t + \frac{1}{2} a_x t^2 \\ &= 28 \times 5 - \frac{1}{2} \times 4 \times (5)^2 = 90 \text{ m} \\ y_5 &= u_y t + \frac{1}{2} a_y t^2 \\ &= 1 \times 5 - \frac{1}{2} \times 7 \times (5)^2 = -82.5 \text{ m} \end{aligned}$$

Example 11.33 A particle moves along a path $y = \frac{x^3}{3}$ with uniform speed of 8 m/s. What are the x and y component of velocity when $x = 3$ m?

Solution We know that

$$\begin{aligned} y &= \frac{x^3}{3} & (1) \\ v &= 8 \text{ m/s} \end{aligned}$$

To find v_x and v_y ,

Differentiating Eq. (1), we get

$$\frac{dy}{dx} = \frac{3x^2}{3} = x^2$$

310 ELEMENTS OF CIVIL ENGINEERING AND ENGINEERING MECHANICS

$$\frac{dy}{dx} = \tan \theta = x^2 \text{ (where } x = 3\text{)}$$

$$\tan \theta = 9$$

$$\theta = \tan^{-1}(9) = 83.66^\circ$$

$$v_x = v \cos \theta = 8 \cos 83.66^\circ = 0.88 \text{ m/s}$$

$$v_y = v \sin \theta = 8 \sin 83.66^\circ = 7.95 \text{ m/s}$$

CURVILINEAR MOTION IN POLAR COORDINATES

The curvilinear motion of particle can be expressed in terms of rectangular components and components along the tangent and normal to the path of particle.

In certain problems the position of particle is more conveniently described by its polar coordinates. In that case it is much simpler to resolve the velocity and acceleration of particle into components that are parallel and perpendicular to the position vector ' r ' of the particle. These components are called radial and transverse components.

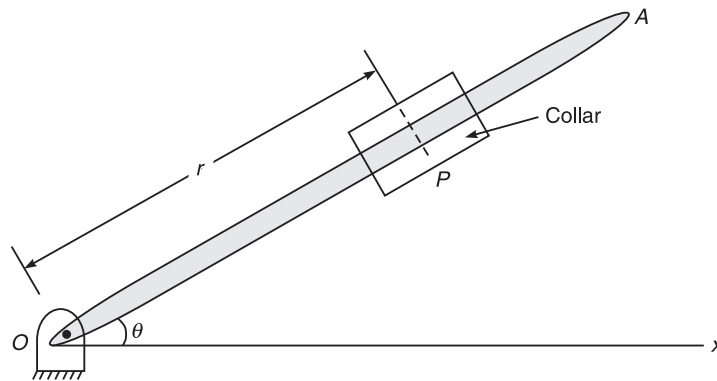

Figure 11.33

Consider a collar P sliding outward along a straight rod OA , which itself is rotating about fixed point O . It is much convenient to define the position of collar at any instant in terms of distance ' r ' from the point ' O ' and angular position ' θ ' of rod OA with x axis.

Thus polar coordinates of point P these are (r, θ) .

It can be shown that the radial and transverse components of velocity are $v_r = \dot{r}$ (Radial component directed along position vector ' r ')

Transverse component

$$v_\theta = r\dot{\theta}$$

(Transverse component directed along the normal to the position vector ' r ')

$$\therefore \text{ Total velocity } = v = \sqrt{v_r^2 + v_\theta^2}$$

$$\therefore \text{ Radial component of acceleration } a_r = \ddot{r} - r(\dot{\theta})^2$$

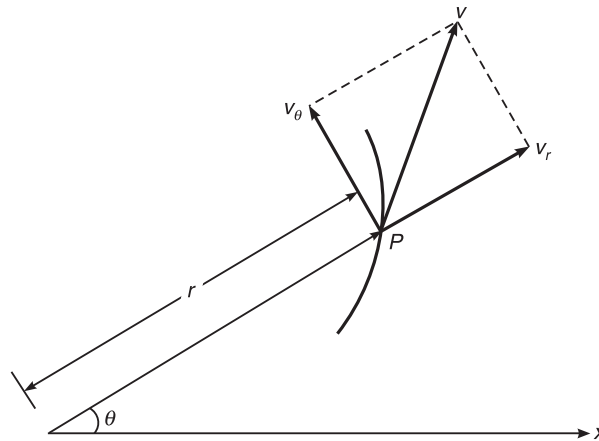

Figure 11.34

Transverse component of acceleration $a_\theta = r\ddot{\theta} + 2\dot{r}\dot{\theta}$

$$\therefore \text{Total acceleration} = a = \sqrt{a_r^2 + a_\theta^2}$$

The component of velocity and acceleration are related as

$$a_r = \dot{v}_r - v_\theta \dot{\theta}$$

$$a_\theta = \dot{v}_\theta - v_r \dot{\theta}$$

From the above equation it can be seen that ' a_r ' is not equal to ' \dot{v}_r ' and ' a_θ ' is not equal to ' \dot{v}_θ '.

It would be noted that radial component of velocity and acceleration are taken to the positive in the same sense of position vector ' r '.

Transverse components of velocity and acceleration are taken to the positive if pointing towards the increasing value of θ .

To understand the physical significance of above results let us assume the following two situations.

- (i) If ' r ' is of constant length and θ varies. Then t reduces to rotation along circular path.

$$r = \text{constant}$$

$$\dot{r} = \ddot{r} = 0$$

$$v_\theta = r\dot{\theta}$$

$$v_r = \dot{r} = 0$$

$$a_\theta = r\ddot{\theta}$$

$$a_r = -r(\dot{\theta})^2$$

(-ve sign indicates that a_r is directed opposite to the sense of position vector ' r ' or towards 'O')

- (ii) If, only ' r ' varies and θ constant it then resolves a rectilinear motion along a fixed direction θ

312 ELEMENTS OF CIVIL ENGINEERING AND ENGINEERING MECHANICS

$$\theta = \text{constant}$$

$$\dot{\theta} = \ddot{\theta} = 0$$

$$v_{\theta} = 0$$

$$v_r = \dot{r} a_{\theta} = 0$$

$$a_r = \ddot{r}$$

Example 11.34 The rotation of rod OA is defined by the relation $\theta = \pi/2 (4t - 3t^2)$. A collar P slides along this rod in such a way that its distance from O is given by $r = 1.25t^2 - 0.9t^3$. In these relations ' θ ' is expressed in radians, ' r ' is in metres, t is in s. Determine (1) The velocity of collar (2) The total acceleration of collar. When $t = 1$ s.

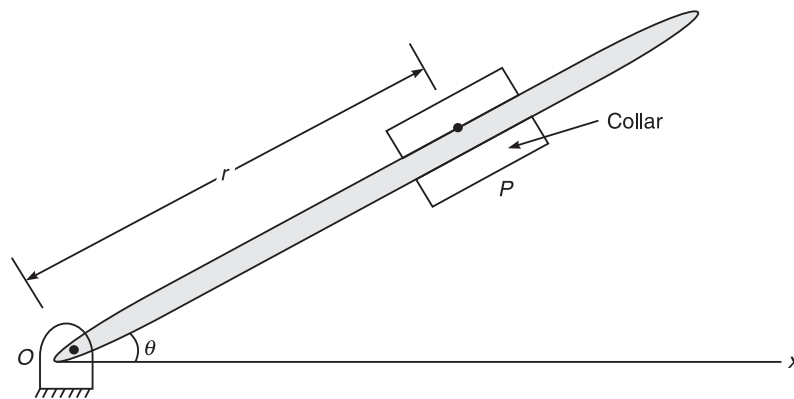

Figure 11.35

Solution Equations of motion are

$$\theta = \frac{\pi}{2} (4t - 3t^2)$$

$$r = 1.25t^2 - 0.9t^3$$

Evaluating θ , $\dot{\theta}$, $\ddot{\theta}$, r , \dot{r} and \ddot{r} at $t = 1$ s

$$\theta = \frac{\pi}{2} (4 - 3) = \frac{\pi}{2} \text{ rad}$$

$$\dot{\theta} = \frac{\pi}{2} (4 - 6t) = \text{at } t = 1 \text{ s}$$

$$\dot{\theta} = \frac{\pi}{2} (4 - 6) = -\pi \text{ rad/s}$$

$$\ddot{\theta} = \frac{\pi}{2} (0 - 6) = -3\pi \text{ rad/s}^2$$

Further,

$$\begin{aligned}r &= 1.25 - 0.9 = 0.35 \text{ m} \\ \dot{r} &= 1.25 \times 2t - 3 \times 0.9t^2 \\ \dot{r} &= 2.5 \times 2.7 = -0.2 \text{ m/s} \\ \ddot{r} &= 2.5 - 2 \times 2.7t \\ \ddot{r} &= 2.5 - 5.4 = -2.9 \text{ m/s}^2\end{aligned}$$

\therefore Velocity of collar P .

Radial component of velocity = $v_r = \dot{r} = -0.2 \text{ m/s}$

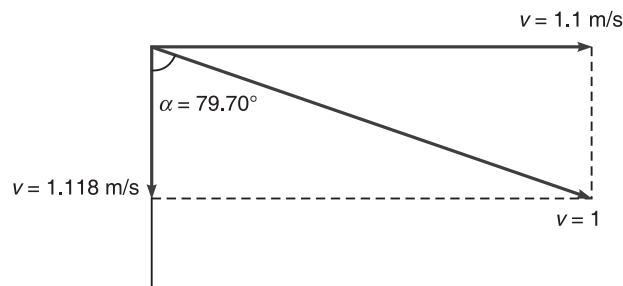

Figure 11.36

Transverse component of velocity

$$v_\theta = r \dot{\theta} = -0.35(\pi) = -1.1 \text{ m/s}$$

$$v = \sqrt{v_r^2 + v_\theta^2} = 1.118 \text{ m/s}$$

$$\tan \alpha = \frac{v_\theta}{v_r} = \frac{-1.1}{-0.2} = 79.70^\circ$$

Acceleration of collar P

$$a_r = \ddot{r} - r(\dot{\theta})^2$$

$$a_r = -2.9 - 0.35(-\pi)^2$$

$$a_r = -6.35 \text{ m/s}^2$$

$$a_\theta = r \ddot{\theta} + 2\dot{r}\dot{\theta}$$

$$a_\theta = 0.35(-3\pi) + 2(-0.2)(-\pi)$$

$$a_\theta = -2.04 \text{ m/s}^2$$

$$a = \sqrt{(a_r)^2 + (a_\theta)^2} = 6.667 \text{ m/s}^2$$

$$\tan \theta = \frac{a_\theta}{a_r} = \frac{-2.04}{-6.35} = 17.8^\circ$$

314 ELEMENTS OF CIVIL ENGINEERING AND ENGINEERING MECHANICS

Example 11.35 A particle moves along the spiral shown in Figure 11.37. The motion of particle is defined by relations $r = 10t$ and $\theta = 2\pi t$.

' r ' is expressed in cm, θ in radian, t is in s. Determine the velocity and acceleration of particle when (i) $t = 0$ and (ii) $t = 0.3$ s.

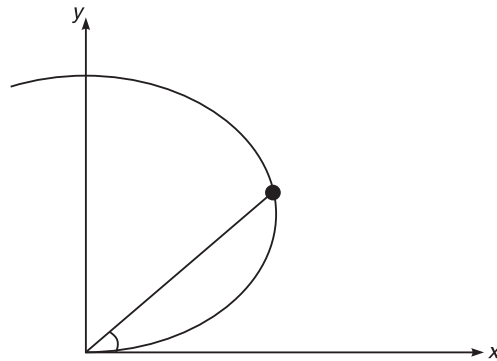

Figure 11.37

Solution Equations of motion are

$$r = 10t \text{ and } \theta = 2\pi t$$

Evaluating θ , $\dot{\theta}$, $\ddot{\theta}$ and r , \dot{r} , \ddot{r} at $t = 0$ s

$$\left. \begin{array}{l} \theta = 2\pi t \\ \dot{\theta} = 2\pi \end{array} \right\} \text{ at } t = 0 \quad \begin{array}{l} \theta = 0 \\ \dot{\theta} = 2\pi \text{ rad/s} \\ \ddot{\theta} = 0 \end{array}$$

$$\left. \begin{array}{l} r = 10t \\ \dot{r} = 10 \end{array} \right\} \text{ at } t = 0 \quad \begin{array}{l} r = 0 \\ \dot{r} = 10 \text{ cm/s} \\ \ddot{r} = 0 \end{array}$$

(i) Velocity

$$v_r = \dot{r} = 10 \text{ cm/s}$$

$$v_\theta = r\dot{\theta} = 1 \times 0 \times 2\pi = 0$$

$$v = \sqrt{(v_r)^2 + (v_\theta)^2} = \sqrt{(10)^2 + (0)^2} = 10 \text{ cm/s}$$

(i) Acceleration

$$a_r = \ddot{r} - r(\dot{\theta})^2$$

$$2a_r = 0 - 0(2\pi)^2 = 0$$

$$a_\theta = r\ddot{\theta} - 2\dot{r}\dot{\theta}$$

$$a_\theta = 0(0) + 2 \times 10 \times 2\pi = 125.6 \text{ cm/s}^2$$

$$a = \sqrt{(a_r)^2 + (a_\theta)^2} = 125.6 \text{ cm/s}^2 \text{ along } a_\theta$$

Example 11.36 The plane curvilinear motion of particle is defined in polar coordinates by $r = t^3/3 + 2t$ and $\theta = 0.3t^2$. Find the magnitude of velocity, acceleration of path when $t = 1$ s.

Solution Equations of motion are

$$r = \frac{t^3}{3} + 2t \text{ and } \theta = 0.3t^2$$

Evaluating θ , $\dot{\theta}$, $\ddot{\theta}$ and r , \dot{r} , \ddot{r} at $t = t$ s

$$\left. \begin{array}{l} \theta = 0.3t^2 \\ \dot{\theta} = 2 \times 0.3t \\ \ddot{\theta} = 0.6 \end{array} \right\} \text{ at } t = 1 \text{ s} \quad \left. \begin{array}{l} \theta = 0.3 \text{ rad} \\ \dot{\theta} = 0.6 \text{ rad/s} \\ \ddot{\theta} = 0.6 \text{ rad/s}^2 \end{array} \right\}$$

$$\left. \begin{array}{l} r = \frac{t^3}{3} + 2t \\ \dot{r} = t^2 + 2 \\ \ddot{r} = 2t \end{array} \right\} \text{ at } t = 1 \text{ s} \quad \left. \begin{array}{l} r = 2.33 \text{ m} \\ \dot{r} = 3 \text{ m/s} \\ \ddot{r} = 2 \text{ m/s}^2 \end{array} \right\}$$

Velocity

$$\begin{aligned} v_r &= \dot{r} = 3 \text{ m/s} \\ v_\theta &= r\dot{\theta} = 2.33 \times 0.6 \end{aligned}$$

Centrifugal Force

Centrifugal means Tending or causing to recede from the Centre or the body moving away from the centre during a curvilinear motion.

Centrifugal force is the effect that tends to move an object away from the centre of a circle it is rotating about as a consequent of inertia.

In a rotating reference frame, the apparent force that seems to push all bodies away from the centre of rotation of the frame and is a consequence of the body's mass and the frame's angular speed.

This force makes the bodies experience a throwing force radially away from the centre, which pulls away the body, deviating from the curvilinear path.

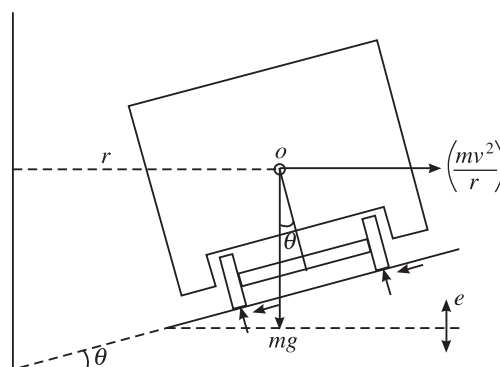

Figure 11.38

Super Elevation

If the road surface is horizontal, then the centrifugal force acting radially outwards will draw the vehicle away from the centre effecting lateral slipping of the vehicle. If this is to be prevented, then the frictional resistance offered at the wheel and road has to balance this centrifugal force.

To prevent lateral slipping of the vehicle due to the centrifugal force, the road edge away from the centre (outer edge) will be slightly raised above the inner edge by a vertical height e .

Consider vehicle of mass of m negotiate a circular curve of radius r with a velocity v . Let the angle with which the road surface be inclined at an angle θ with respect to horizontal surface.

For dynamic equilibrium along the road surface

$$mg \sin \theta = \left(\frac{mv^2}{r} \right) \cos \theta$$

$$\tan \theta = \frac{\left(\frac{mv^2}{r} \right)}{mg} = \frac{v^2}{gr}$$

Where θ is the banking angle known as super elevation.

For highways, the super elevation is provided for average speeds of the vehicles.

Problem

An automobile is supposed to negotiate with a speed of 120 kmph, a curvilinear track of radius 250 m. Find the angle of banking so that the vehicle can negotiate the curve without slipping.

$$r = 250 \text{ m, } g = 9.81 \text{ m/s}^2 \text{ (Assumed), } v = 120 \text{ kmph} = \frac{120 \times 1000}{60 \times 60} = 33.33 \text{ m/s}$$

The banking angle θ is given by

$$\tan \theta = \frac{v^2}{gr}$$

$$\tan \theta = \frac{33.33^2}{9.81 \times 250} = 0.4595$$

$$\theta = 26.54^\circ$$

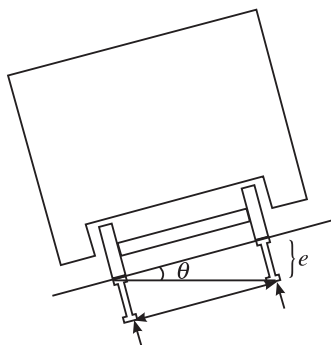

Figure 11.39

A wagon has to negotiate a curve of radius 1000 m. The mass of the wagon is 5000 kg. Find the safe speed of the train, if the outer rail is raised over the inner rail by 18 mm and the distance between the rails is 1 m.

$$r = 1000 \text{ m}, g = 9.81 \text{ m/s}^2 \text{ (Assumed)}, e = 18 \text{ mm}, \tan \theta = \frac{18}{1000}, v = ?$$

The banking angle θ is given by $\theta = \frac{v^2}{gr}$

$$\tan \theta = \frac{18}{1000} = \frac{v^2}{9.81 \times 1000}$$

$$v = \sqrt{9.81 \times 18} = 13.288 \text{ m/s}$$

$$v = \frac{60 \times 60 \times 13.288}{1000} = 47.84 \text{ kmph}$$

PROJECTILES

Whenever a particle is projected upwards with some inclination to the horizontal (but not vertical), it travels in the air and traces a parabolic path and falls on the ground point (target) other than the point of projection. The particle itself is called projectile and the path traced by the projectile is called trajectory.

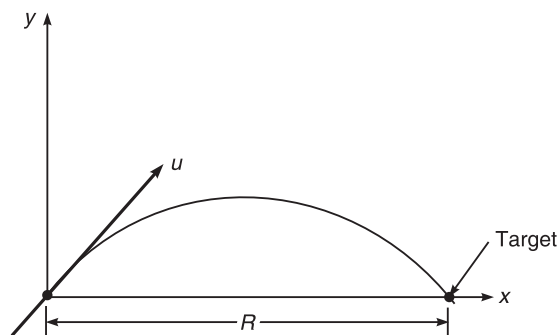

Figure 11.40

Terms used in projectile

1. **Velocity of projection (u):** It is the velocity with which projectile is projected in the upward direction with some inclination to the horizontal.
2. **Angle of projection (α):** It is the angle with which the projectile is projected with respect to horizontal.
3. **Time of flight (T):** It is the total time required for the projectile to travel from the point of projection to the point of target.

318 ELEMENTS OF CIVIL ENGINEERING AND ENGINEERING MECHANICS

4. **Horizontal range (R):** It is the horizontal distance between the point of projection and target point.
5. **Vertical height (h):** It is the vertical distance/height reached by the projectile from the point of projection.

Some relations

Time of flight: Let T be the time of flight. We know that the vertical ordinate at any point on the path of projectile after a time T is given by

$$y = (u \sin \alpha) t - \frac{1}{2} g t^2$$

When the projectile hits the ground, say at B : $y = 0$ at $t = T$
Above equation becomes

$$0 = (u \sin \alpha) t - \frac{1}{2} g t^2$$

$$(u \sin \alpha) = \frac{1}{2} g t$$

$$T = \frac{2u \sin \alpha}{g}$$

Horizontal range of the projectile: During the time of flight, the horizontal component of velocity of projectile = $u \cos \alpha$

{Horizontal distance of the projectile} = $R =$ {Horizontal component of velocity of projection} {Time of flight} = $u \cos \alpha \times T$

$$R = u \cos \alpha \times \frac{2u \sin \alpha}{g} = \frac{u^2 \sin (2\alpha)}{g}$$

$\sin (2\alpha)$ will be maximum only when $\sin 2\alpha = 1$

$$\sin 2\alpha = \sin 90 \text{ or } \alpha = 45^\circ$$

Hence maximum horizontal range is given by

$$R_{\max} = \frac{u^2 \sin 90}{g} = \frac{u^2}{g}$$

Maximum height attained by the projectile: When the projectile reaches its maximum height, vertical component of velocity of projection becomes zero.

$$v^2 - u^2 = 2gs$$

$$0 - u^2 \sin^2 \alpha = -2gh_{\max}$$

$$h_{\max} = \frac{u^2 \sin^2 \alpha}{2g}$$

Time required to reach the maximum height is given by

$$\begin{aligned}v &= u + at \\0 &= u \sin \alpha - gt \\ \text{then} \quad t &= \frac{u \sin \alpha}{g}\end{aligned}$$

Motion of projectile: Let a particle be projected upward from a point O at an angle α with horizontal with an initial velocity of u m/s as shown in Figure 11.39. Now resolving this velocity into two components, we get

$$\begin{aligned}u_x &= u \sin \alpha \\u_y &= u \cos \alpha\end{aligned}$$

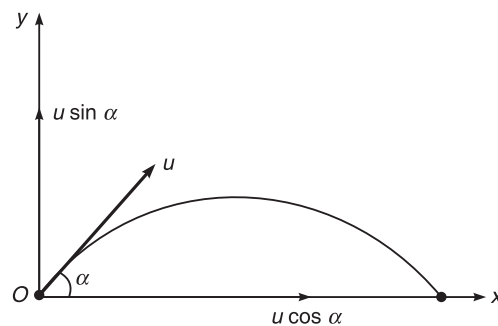

Figure 11.41

The vertical component of velocity is always affected by acceleration due to gravity. The particle will reach the maximum height when vertical component becomes zero. The horizontal component of velocity will remain constant since there is no effect of acceleration due to gravity. The combined effect of horizontal and vertical components of velocity will move the particle along some path in air and then fall on the ground other than the point of projection.

Equation for the path of projectile (Trajectory equation): Let a particle is projected at a certain angle from point O . The particle will move along a certain path OPA in the air and will fall down at A .

Let u = velocity of projection
 α = angle of projection

After ' t ' seconds, let a particle reach any point ' P ' with x and y as coordinates as shown in Figure 11.40.

We know that, horizontal component of velocity of projection = $u \cos \alpha$

Vertical component of velocity of projection = $u \sin \alpha$

Therefore, $x = u \cos \alpha t$ (1)

$$y = u \sin \alpha t - \frac{1}{2}gt^2 \quad (2)$$

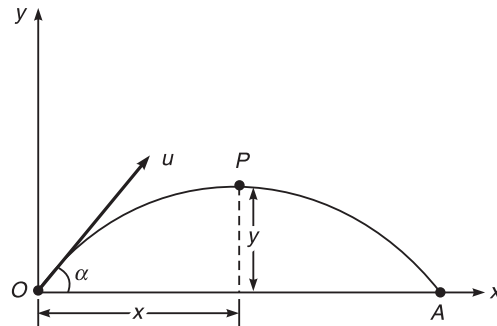

Figure 11.42

From Eq. (1)

$$t = \frac{x}{u \cos \alpha}$$

substitute in Eq. (2), we get

$$y = u \sin \alpha \left(\frac{x}{u \cos \alpha} \right) - \frac{1}{2} g \left(\frac{x}{u \cos \alpha} \right)^2$$

or

$$y = x \tan \alpha - \frac{gx^2}{2u^2 \cos^2 \alpha}$$

Example 11.37 A particle is projected at an angle of 60° with horizontal. The horizontal range of particle is 5 km. Find

- (i) Velocity of projection
- (ii) Maximum height attained by the particle

Solution Data given; $R = 5 \text{ km} = 5000 \text{ m}$, $g = 9.81 \text{ m/s}^2$ and $\alpha = 60^\circ$

To find: u and h_{\max}

We know that
$$R = \frac{u^2 \sin 2\alpha}{g} \quad (1)$$

Substituting the known values in Eq. (1), we get

$$u = 237.98 \text{ m/s}$$

Again, maximum height attained by the particle

$$h_{\max} = \frac{u^2 \sin^2 \alpha}{2g} = \frac{(237.98)^2 \sin^2 60}{2 \times 9.81} = 2164.9 \text{ m}$$

Example 11.38 A particle is projected in air with a velocity of 100 m/s at an angle of 30° with horizontal. Find the horizontal range, maximum height attained and time of flight.

Solution Data given: $u = 100 \text{ m/s}$, $g = 9.81 \text{ m/s}^2$ and $\alpha = 30^\circ$

To find: R , T and h_{\max}

We know that, horizontal range

$$R = \frac{u^2 \sin 2\alpha}{g} = \frac{(100)^2 \sin 60}{9.81} = 882.79 \text{ m}$$

Maximum height attained

$$h_{\max} = \frac{u^2 \sin^2 \alpha}{2g} = \frac{(100)^2 \sin^2 30}{2 \times 9.81} = 127.42 \text{ m}$$

Time of flight

$$T = \frac{2u \sin \alpha}{g} = \frac{2(100) \sin 30}{9.81} = 10.19 \text{ s}$$

The body is projected at such an angle that the horizontal range is three times the greatest height. Calculate the angle of projection.

It is given that

$$R = 3h_{\max} \quad (1)$$

We know that

$$R = \frac{u^2 \sin 2\alpha}{g} \quad \text{and} \quad h_{\max} = \frac{u^2 \sin^2 \alpha}{2g}$$

Substituting the values of R and h_{\max} in Eq. (1), we get

$$\frac{u^2 \sin 2\alpha}{g} = 3 \times \frac{u^2 \sin^2 \alpha}{2g}$$

$$2 = \frac{3}{2} \tan \alpha \quad \text{or} \quad \alpha = 53.8^\circ$$

Example 11.39 A projectile is aimed at a mark on a horizontal plane through the point of projection and falls 12 m short when the angle of projection is 15° , while it overshoots the mark by 24 m, when the angle of projection is 45° . Find the angle of projection to hit the mark. Assume no air resistance. Take the velocity of projection constant in all cases.

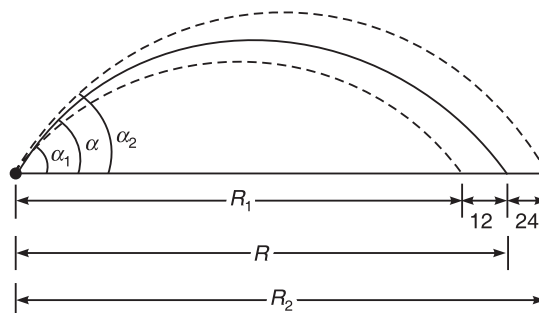

Figure 11.43

Solution Let R = horizontal range for the actual path.

322 ELEMENTS OF CIVIL ENGINEERING AND ENGINEERING MECHANICS

R_1 and R_2 = horizontal ranges for first and second imaginary paths respectively.

From figure,

$$R_1 = R - 12 \quad \text{and} \quad R_2 = R + 24$$

Using the equation for horizontal range, we have

$$R = \frac{u^2 \sin 2\alpha}{g} \quad (1)$$

Similarly

$$R_1 = \frac{u^2 \sin 2\alpha_1}{g}$$

$$R - 12 = \frac{u^2 \sin 30}{g} = 0.5 \frac{u^2}{9.81} \quad (2)$$

$$R_2 = \frac{u^2 \sin 2\alpha_2}{g}$$

$$R + 24 = \frac{u^2 \sin 90}{g} = \frac{u^2}{9.81} \quad (3)$$

Dividing Eqs. (2) by (3), we get

$$\left(\frac{R - 12}{R + 24} \right) = \frac{0.5}{1} \quad \text{or} \quad R = 48 \text{ m}$$

Substituting the value of R in Eq. (3), we get

$$u = 26.57 \text{ m/s}$$

Now substitute the value of R and u in Eq. (1), we get

$$\alpha = 20.9^\circ$$

Example 11.40 A bullet is fired upwards at an angle of 30° to the horizontal from a point P on a hill and it strikes a target which is 80 m lower than B . The initial velocity of bullet is 100 m/s. Calculate

- The maximum height with which the bullet will rise above the horizontal
- The actual velocity with which it strikes the target
- The total time required for the flight of bullet

Neglect the air resistance.

Solution Vertical downward distance of target from the point of projection = 80 m.

- The maximum height attained by the bullet above the point of projection P is given by

$$h_{\max} = \frac{u^2 \sin^2 \alpha}{2g} = \frac{100^2 \sin^2 30}{2 \times 9.81} = 127.42 \text{ m}$$

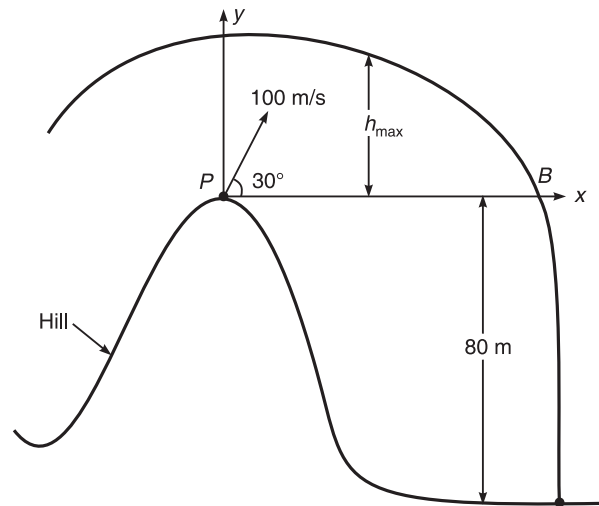

Figure 11.44

- (b) The actual velocity with which bullet strikes the target. In Figure 11.42 point A is the highest point of the projectile. At the highest point the vertical component of velocity is zero.

Consider the motion from A to target:

Let v_1 = vertical component of velocity at A = 0

v_2 = vertical component of velocity while striking the target

s = vertical distance between A and target = 127.42 + 80 = 207.42 m

We know that

$$v_2^2 - v_1^2 = 2gs$$

$$v_2^2 - 0 = 2 \times 9.81 \times 207.42$$

Therefore

$$v_2 = 63.79 \text{ m/s}$$

Vertical component of velocity while striking the target = $v_2 = 63.79 \text{ m/s}$

Horizontal component of velocity remains constant = $u \cos \alpha = 100 \cos 30 = 86.6 \text{ m/s}$

Therefore, actual velocity with which bullet strikes the target

$$\sqrt{u_1^2 + v_2^2} = 107.55 \text{ m/s}$$

- (c) The total time required for the flight of bullet

t_1 = time of flight from P to A

t_2 = time of flight from A to target

Total time of flight

$$T = t_1 + t_2$$

Consider the motion from P to A:

Initial velocity in vertical direction at P = $u \sin \alpha = 100 \sin 30 = 50 \text{ m/s}$

Final velocity in vertical direction at A = 0

324 ELEMENTS OF CIVIL ENGINEERING AND ENGINEERING MECHANICS

Final velocity = initial velocity $- gt_1$

$$0 = 50 - 9.81 \times t_1$$

$$t_1 = 5.096 \text{ s}$$

Now consider the motion from A to target:

Vertical component of velocity at A = 0

Vertical component of velocity at target = 63.79 m/s

Therefore, final velocity = initial velocity $+ gt_1$

$$63.79 = 0 + 9.81 \times t_2$$

$$t_2 = 6.5 \text{ s}$$

Therefore, total time of flight

$$T = t_1 + t_2 = 11.596 \text{ s.}$$

Example 11.41 A projectile is fired from the edge of 150 m high cliff with an initial velocity of 180 m/s at an angle of elevation of 30° with horizontal. Neglecting the air resistance, find (a) The greatest elevation above the ground reached by the projectile (b) The horizontal distance from the gun to the point where the projectile strikes the ground.

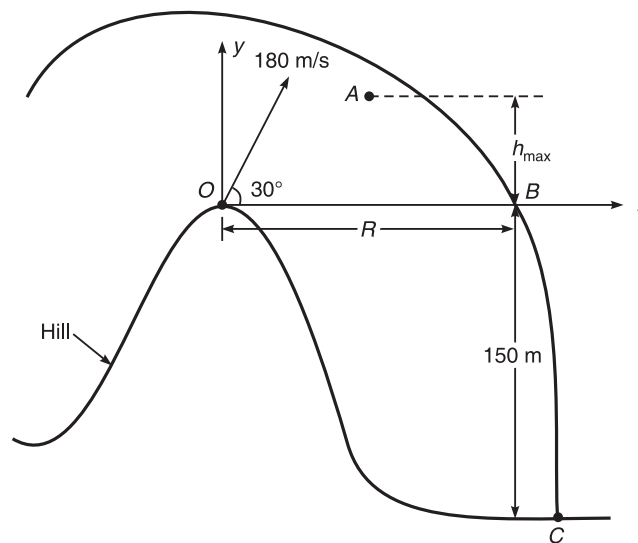

Figure 11.45

Solution

- (a) The greatest elevation above the ground reached by the projectile
Let a gun is fired at point O and strikes at the ground point C

$$h_{\max} = \frac{u^2 \sin^2 \alpha}{2g} = \frac{180^2 \sin^2 30}{2 \times 9.81} = 412.84 \text{ m}$$

Hence the greatest elevation above the ground reached by the projectile = $150 + h_{\max} = 562.84 \text{ m.}$

- (b) The horizontal distance from the gun to the point where the projectile strikes the ground
We know that

$$T = t_1 + t_2$$

Consider motion from O to A

$$v = u - gt_1 \quad (u \text{ and } v \text{ are the vertical components of velocity})$$

$$0 = 180 \times \sin 30 - 9.81t_1, \quad t_1 = 9.17 \text{ s.}$$

Now consider motion from A to C

$$v = u - gt_2 \quad (1)$$

Where

$$u = \text{vertical component of velocity at } A = 0$$

$$v = \text{vertical component of velocity at } C$$

We know that

$$v^2 - u^2 = 2gs$$

$$v^2 - 0 = 2 \times 9.81 \times 562.84$$

$$v = 105.085 \text{ m/s}$$

Substituting the values of v and u in Eq. (1), we get, $t_2 = 10.7$ s

Therefore, $9.17 + 10.7 = 19.87$ s.

Now, horizontal distance between O and C = horizontal component of velocity $\times T$
 $= 180 \cos 30 \times 19.87 = 3097.42$ m

Example 11.42 Determine from first principle the angle at which the bullet must be fired over a horizontal plane such that the greatest height attained by it is equal to the greatest distance travelled on the plane.

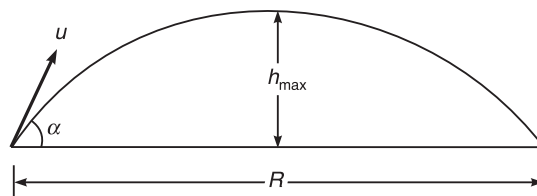

Figure 11.46

Solution We have

$$R = h_{\max} \quad (1)$$

$$R = \frac{u^2 \sin 2\alpha}{g}$$

$$h_{\max} = \frac{u^2 \sin^2 \alpha}{2g}$$

326 ELEMENTS OF CIVIL ENGINEERING AND ENGINEERING MECHANICS

Substituting the values of R and h_{\max} in Eq. (1), we get

$$\frac{u^2 \sin 2\alpha}{g} = \frac{u^2 \sin^2 \alpha}{2g}$$

Therefore, $\alpha = 70.48^\circ$.

Example 11.43 Determine the position at which the ball is thrown up the plane will strike the inclined plane as shown in Figure 11.45. The initial velocity is 30 m/s and angle of projection is $\tan^{-1}(4/3)$ with horizontal.

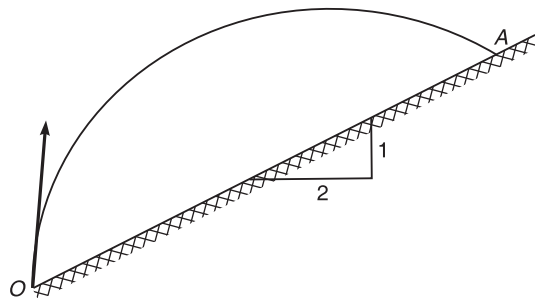

Figure 11.47

Solution Let the ball strikes the point A with elevation y above O . As the slope is 1 : 2

$$\therefore \quad x = 2y$$

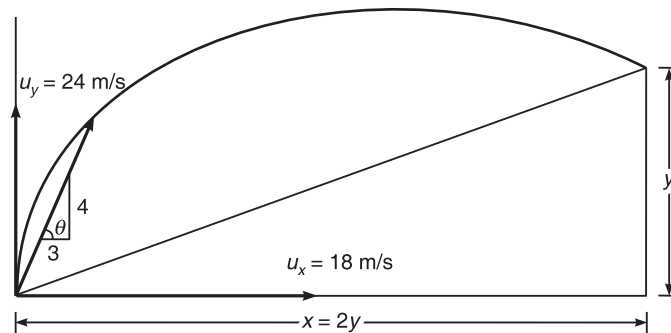

Figure 11.48

Horizontal component of velocity

$$u_x = u \cos \theta = 30 \times \frac{3}{5} = 18 \text{ m/s}$$

Vertical component of velocity

$$u_y = u \sin \theta = 30 \times \frac{4}{5} = 24 \text{ m/s}$$

For the motion of ball along y direction

$$y = u \sin \theta \times t - gt^2 = 24t - \frac{9.81}{2}t^2$$

$$y = 24t - 4.905t^2 \quad (1)$$

For the motion of ball along x direction

$$x = 2y = u \cos \theta t = 18t$$

$$y = 9t$$

Substituting the value of y in Eq. (1), we get

$$t = 3.058 \text{ s and also } x = 55.046 \text{ s, } y = 27.523 \text{ s.}$$

Example 11.44 A bullet is from a gun with a initial velocity of 250 m/s to hit a target. The target is located at a horizontal distance of 3750 m and 625 m above the gun (point of projection). Determine the minimum of angle of projection so that the bullet will hit the target.

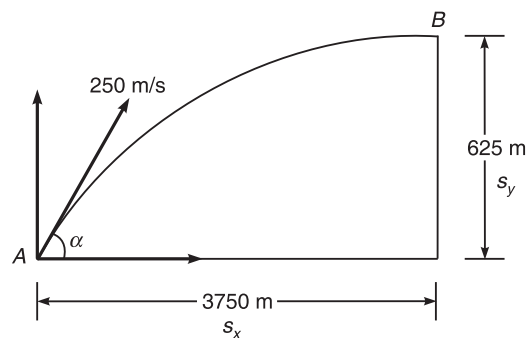

Figure 11.49

Solution

Let, $\alpha =$ angle of projection, $u = 250 \text{ m/s}$

Horizontal component of velocity $= u \cos \alpha = 250 \cos \alpha$

Vertical component of velocity $= u \sin \alpha = 250 \sin \alpha$

Consider the horizontal motion ($a_x = 0$)

$$s_x = u_x t + \frac{1}{2} a_x t^2$$

$$3750 = 250 \cos \alpha t \quad (1)$$

Consider the vertical motion

$$s_y = u_y t + \frac{1}{2} a_y t^2$$

$$625 = 250 \sin \alpha t - \frac{1}{2} \times 9.81 \times t^2 \quad (2)$$

328 ELEMENTS OF CIVIL ENGINEERING AND ENGINEERING MECHANICS

From (1) $t = \frac{3750}{250 \cos \alpha}$ and substitute in (2), we get

$$625 = 250 \sin \alpha \left(\frac{3750}{250 \cos \alpha} \right) - \frac{1}{2} \times 9.81 \times \left(\frac{3750}{250 \cos \alpha} \right)^2$$

$$625 = 3750 \tan \alpha - 593.5 \sec^2 \alpha$$

$$625 = 3750 \tan \alpha - 593.5 (1 + \tan^2 \alpha)$$

By solving the above quadratic equation, we get

$$\tan \alpha = 5.97 \quad \text{or} \quad \alpha = 80.49^\circ$$

$$\tan \alpha = 0.343 \quad \text{or} \quad \alpha = 18.96^\circ$$

\therefore Minimum angle of projection = 18.96° .

Example 11.45 A toy missile is projected with an initial velocity of 20 m/s. If the missile lands 15 m away at the same level, what must have been the angle of projection?

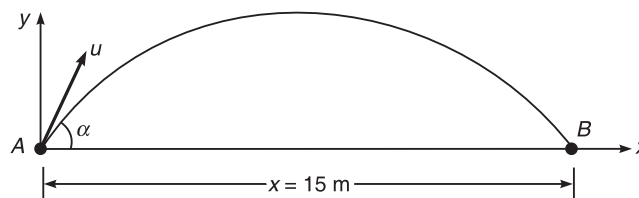

Figure 11.50

Solution Consider point B:

$$y = 0, x = 15 \text{ m and } g = 9.81 \text{ m/s}^2$$

We have

$$y = x \tan \alpha - \frac{gx^2}{2u^2 \cos^2 \alpha}$$

$$0 = 15 \tan \alpha - \frac{9.81 \times 15^2}{2 \times 20^2 \cos^2 \alpha} = 15 \tan \alpha - 2.756 \sec^2 \alpha$$

$$0 = 15 \tan \alpha - 2.756 (1 + \tan^2 \alpha)$$

$$15 \tan \alpha - 2.756 \tan^2 \alpha - 2.756$$

\therefore $\alpha = 10.76^\circ$ (minimum)

$$\alpha = 79.22^\circ$$
 (maximum)

Example 11.46 A boy throws a ball so that it may just clear a wall 3.6 m high. The boy is at a distance of 4.8 m from the wall. The ball was found to hit the ground at a distance of 3.6 m on the other side of wall. Find the least velocity with which ball can be thrown.

Solution The equation of path with point of projection as origin is given by

$$y = x \tan \alpha - \frac{gx^2}{2u^2 \cos^2 \alpha} \quad (1)$$

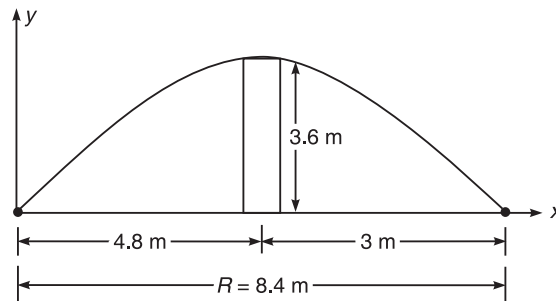

Figure 11.51

Substituting $x = 4.8$ m and $y = 3.6$ m, we get

$$3.6 = 4.8 \tan \alpha - \frac{g(4.8)^2}{2u^2 \cos^2 \alpha} \quad (2)$$

We know that

$$R = \frac{u^2 \sin 2\alpha}{g} \quad (3)$$

Substitute the value of u^2/g in Eq. (2), we get

$$3.6 = 4.8 \tan \alpha - \frac{(4.8)^2 \sin 2\alpha}{2 \cos^2 \alpha \times 8.4}$$

$$3.6 = 4.8 \tan \alpha - 2.74 \tan \alpha$$

$$\therefore \alpha = 60.2^\circ$$

Substituting the value of α in Eq. (3), we get

$$u = 9.7 \text{ m/s}$$

Motion of a body thrown horizontally from a certain height into air

The figure shows a body thrown horizontally from certain height ' H ' into air. At ' B ' there is only horizontal component of velocity. As the body moves in the air towards the ground, the body has both horizontal and vertical components of velocity.

The horizontal component of velocity from B to A remains constant and will be equal to u . But the vertical component of velocity in the downward direction will be subjected to gravitational force and hence will not be a constant.

$$\therefore \text{Resultant velocity} = R = \sqrt{u^2 + v^2} \text{ and } \theta = \tan^{-1} \left(\frac{v}{u} \right)$$

(i) Vertical downward distance travelled by the body is given by

$$H = (\text{vertical component of velocity at } B)t + \frac{1}{2}gt^2$$

$$H = 0 + \frac{1}{2}gt^2 = \frac{1}{2}gt^2$$

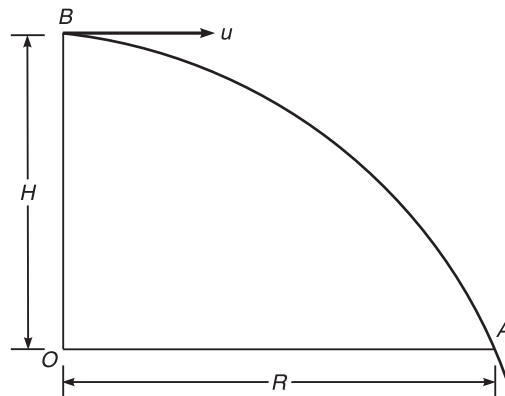

Figure 11.52

(ii) The horizontal distance travelled by the body

$$R = (\text{horizontal component of velocity at } B)t$$

$$\therefore R = ut$$

(iii) The vertical component of velocity at point A is obtained from the equation

$$v = u + gt$$

or
$$v = gt$$

$$\text{Resultant velocity at } A = R = \sqrt{u^2 + v^2}$$

Example 11.47 An aircraft is moving horizontally at a speed of 108 km/h at an altitude of 1000 m towards a target on the ground releases a bomb which hits the target. Estimate the horizontal distance of aircraft from the target when it release a bomb. Calculate also the direction and velocity with which bomb hits the target.

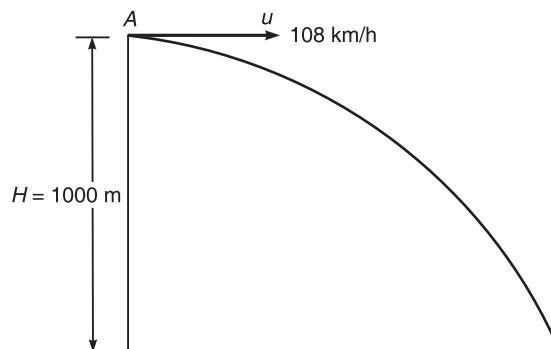

Figure 11.53

Solution

$$\text{Speed of aircraft} = \frac{108 \times 1000}{60 \times 30} = 30 \text{ m/s}$$

Horizontal velocity of bomb = $u = 200$ m/s

Height $H = 1000$ m

Let ' t ' be the time required for the bomb to hit the target

We know that

$$H = \frac{1}{2}gt^2$$

$$\therefore 1000 = \frac{1}{2} \times 9.81 \times t^2 \quad \text{or} \quad t = 14.278 \text{ s}$$

- (i) Horizontal distance of aircraft from the target when it release a bomb.

We know that

$$R = u \times t = 30 \times 14.278 = 428.57 \text{ m}$$

- (ii) Velocity with which bomb hits the target.

Vertical component of velocity = $v = gt = 9.81 \times 14.278 = 139.9$ m/s

Horizontal component of velocity = $u = 30$ m/s

$$\text{Resultant velocity} = R = \sqrt{u^2 + v^2} = 143.08 \text{ m/s}$$

$$\text{Direction} = \theta = \tan^{-1} \left(\frac{v}{u} \right) = 77$$

EXERCISE PROBLEMS

- The velocity of body changes from 30 m/s to 150 m/s in 20 s. Find the acceleration and distance travelled by the body. (Ans: $a = 6 \text{ m/s}^2$, $s = 1800 \text{ m}$)
- A car starts from a station and moves in a station and moves with a constant acceleration. It covers a distance of 19 m during 10th seconds of its motion. Find the acceleration and velocities after 9th and 10th seconds from the start. (Ans: $a = 2 \text{ m/s}^2$, $v = 18 \text{ m/s}$ and $v = 20 \text{ m/s}$)
- An automobile accelerates from a velocity of 24 km/h to a velocity of 72 km/h in a distance of 160 m. Compute the acceleration and time required. (Ans: $a = 1.11 \text{ m/s}^2$ and $t = 12 \text{ s}$)
- A motorist travelling at 20 m/s. When he observes the traffic light 180 m ahead of him turns red. The traffic light is to stay red for 10 s. If the motorist wishes to pass the light without stopping just as it turns green. Determine the acceleration and speed of the motor as it passes the light. (Ans: $a = -0.4 \text{ m/s}^2$ and $v = 16 \text{ m/s}$)
- A car travels along a straight line between two points at a mean speed of 60 m/s. It then returns over the same path at a mean speed of 40 m/s. What is its mean speed for the entire travel? (Ans: $v = 48 \text{ m/s}$)
- A motorcyclist leaves from a point with an acceleration of 2 m/s^2 . After a lapse of 10 s. A car leaves the same point with an acceleration of 8 m/s^2 . Calculate when and where will the car overtake the motorcyclist. (Ans: $t = 10 \text{ s}$, $s = 400 \text{ m}$)

332 ELEMENTS OF CIVIL ENGINEERING AND ENGINEERING MECHANICS

7. A stone is dropped from a balloon that is ascending at a uniform rate of 10 m/s. The stone takes 10 s to reach the ground. What is the height of balloon at the instant from the ground?
(Ans: $h = -390.5$ m)
8. A body is thrown up with a velocity of 50 m/s. Find the maximum height to which it will reach and time required to reach maximum height. (Ans: $h = 127.42$ m and $t = 5.09$ s)
9. A body is projected vertically upwards with a velocity of 40 m/s. Find how high it will reach and what time will it be 50 m above the point of projection.
(Ans: $h = 81.55$ m and $t = 6.61$ s or $t = 1.54$ s)
10. A stone is dropped from the tower 60 m height and another stone is projected upwards at the same time from the foot of the tower which meets the first stone at the height of 18 m. Find the velocity with which the second stone was projected upward.
(Ans: $u = 20.5$ m/s)
11. A stone is dropped from the top of cliff of height 120 m. After 10 s another stone is thrown down which strikes the first stone at the foot of the cliff. Find the velocity with which the second stone was thrown.
(Ans: $v = 49.05$ m/s)
12. A stone is dropped into well is heard to strike the water in 5 s. Find the depth of water in the well and having a velocity of sound being 335 m/s.
(Ans: $h = 108.16$ m)
13. A train is travelling on a curved track of radius 1000 m at the speed of 180 km/h. The breaks are suddenly applied, causing the train to slow down at uniform rate after 10 s, the speed has been reduced to 100 km/h. Determine the deceleration of the train immediately after the breaks have been applied.
(Ans: $a = 3.35$ m/s²)
14. A car starts from rest on a curved road of 250 m radius and accelerates at a constant tangential acceleration of 0.6 m/s². Determine the distance and the time for which that car will travel before the magnitude of total acceleration attained by it becomes 0.75 m/s².
(Ans: $s = 93.63$ m and $t = 17.67$ s)
15. A car enters a curved portion of the road of radius 200 m travelling at a constant speed of 36 km/h. Determine the velocity and acceleration of the car in terms of the normal and tangential components.
(Ans: $a_n = 0.5$ m/s² and $a_t = 0$ m/s²)
16. A bullet shot is fired with an initial velocity of 40 m/s at an angle of 60° with horizontal. Find time of flight, maximum height and horizontal range of the bullet shot.
(Ans: $T = 7.06$ s, $h_{\max} = 61.16$ m and $R = 141.24$ m)
17. A missile projected from the rocket travel 10 km horizontally at the vertical height of 20 km from the launching point, when it was found that fuel of the rocket had exhausted. At that instant the missile had acquired a velocity of 1600 m/s at an angle of 35° with horizontal. Assuming that there is no air resistance. Calculate (i) The total horizontal distance covered (ii) The time of flight after fuel had completely burnt (iii) Maximum height from the ground.
(Ans: $s = 281.067$ m, $T = 206.82$ s and $h_{\max} = 42926.31$ m)
18. A player throws a ball from a height of 1.6 m above the ground level with a velocity of 10 m/s at an angle of elevation of 40°. It is caught by another player at a height of 0.6 m above the ground level. Find the distance between the players. Also find the maximum height reached by the ball giving horizontal distance of that point from the first player.
(Ans: $R = 11.113$ m and $h_{\max} = 2.1059$ m)

19. A bullet is fired with a velocity of 100 m/s from the top of the tower 54 m high. The angle of projection with horizontal is 60° . Find the maximum height attained from the ground and the time of travel of bullet. Also determine the velocity of bullet after 10 s.

(Ans: $h_{\max} = 384$ m from the top of the tower = 17.611 s. and $v_R = 51.3$ m/s)

20. A particle is projected with a velocity of 100 m/s at an angle of projection of 60° with respect to horizontal from the foot of an inclined plane having inclination 30° with respect to horizontal. Determine the range on inclined plane and time of flight.

(Ans: $R = 679.57$ m and $T = 679.57$ m)

(Hint: $R = \frac{2u^2 \cos \alpha \times \sin(\alpha - \beta)}{g \cos^2 \beta}$ and $T = \frac{2u \sin(\alpha - \beta)}{g \cos \beta}$ and $\alpha = 60^\circ, \beta = 30^\circ$)

ANNEXURE 1

USEFUL RELATIONSHIPS

Mensuration

1. Rectangle

$$\text{Area} = \text{Length} \times \text{breadth}$$

$$\text{Diagonal} = \sqrt{(\text{Length})^2 + (\text{Breadth})^2}$$

$$\text{Perimeter} = 2 (\text{Length} + \text{Breadth})$$

2. Triangle

$$\text{Area} = \frac{1}{2} (\text{Base} \times \text{Height})$$

$$= \sqrt{s(s-a)(s-b)(s-c)}$$

where s is semi perimeter given by

$$s = \frac{a+b+c}{2}$$

and a , b and c are three sides of triangle.

3. Parallelogram

$$\text{Area} = \text{Base} \times \text{Height}$$

$$= \text{Diagonal} \times \text{Offset of diagonal}$$

$$\text{Area} = 2\sqrt{s(s-a)(s-b)(s-d)}$$

where

$$s = \frac{a+b+d}{2}$$

where d is diagonal and a and b are two adjacent sides.

336 ANNEXURE 1: USEFUL RELATIONSHIPS**4. Trapezoid**

$$\text{Area} = \frac{1}{2}(a + b)h$$

where a and b are parallel sides and h is the perpendicular height.

5. Circle

$$\text{Area} = \frac{\pi \times \text{Diameter}^2}{4} = \pi \times \text{Radius}^2$$

$$\text{Perimeter} = \pi \times \text{Diameter} = 2 \times \pi \times \text{Radius}$$

6. Sector

$$\text{Area} = \text{Half angle of sector (in Radians)} \times (\text{Radius})^2$$

7. Arc of circle

$$\text{Length of arc} = \text{Radius} \times \text{Half angle of sector (in Radians)}$$

8. Cylinder

$$\text{Total surface area} = \pi \times \text{Diameter} (\text{Height} + \text{Radius})$$

$$\text{Volume} = \pi \times (\text{Radius})^2 \times \text{Height}$$

$$\text{Surface area (without ends)} = \pi \times \text{Diameter} \times \text{Height}$$

| | | | | | |
|-------------|-------|------------|-----------|---|-----------|
| Micro-Micro | | 10^{-12} | Mega-Mega | | 10^{12} |
| Milli-Micro | | 10^{-9} | Kilo-Mega | | 10^9 |
| Micro | μ | 10^{-6} | Mega | M | 10^6 |
| Milli | m | 10^{-3} | Kilo | k | 10^3 |
| Centi | c | 10^{-2} | Hecto | | 10^2 |
| Deci | | 10^{-1} | Deca | | 10^1 |

Conversions

| | From | To | From | To |
|--------|-------------------|-------------------------|------------------|------------------------|
| Length | 1 cm | 0.3937 inch | 1 m | 1.093 yards |
| | 1 cm | 10 mm | 1 yard | 3 Ft |
| | 1 m | 3.28 Ft | 1 km | 0.621 mile |
| Area | 1 cm ² | 0.155 inch ² | 1 m ² | 10.764 Ft ² |
| Volume | 1 cm ³ | 0.061 inch ³ | 1 m ³ | 35.31 Ft ³ |
| | 1 Litre | 61.02 inch ³ | 1 Litre | 0.22 gallon |

Trigonometric Functions of Angles

| | 0° | 30° | 45° | 60° | 90° | 15° | 75° |
|-------|----------|----------------------|----------------------|----------------------|----------|--------------------------------|--------------------------------|
| Sin | 0 | $\frac{1}{2}$ | $\frac{1}{\sqrt{2}}$ | $\frac{\sqrt{3}}{2}$ | 1 | $\frac{\sqrt{3}-1}{2\sqrt{2}}$ | $\frac{\sqrt{3}+1}{2\sqrt{2}}$ |
| Cos | 1 | $\frac{\sqrt{3}}{2}$ | $\frac{1}{\sqrt{2}}$ | $\frac{1}{2}$ | 0 | $\frac{\sqrt{3}+1}{2\sqrt{2}}$ | $\frac{\sqrt{3}-1}{2\sqrt{2}}$ |
| Tan | 0 | $\frac{1}{\sqrt{3}}$ | 1 | $\sqrt{3}$ | ∞ | $2-\sqrt{3}$ | $2+\sqrt{3}$ |
| Cosec | ∞ | 2 | $\sqrt{2}$ | $\frac{2}{\sqrt{3}}$ | 1 | $\frac{2\sqrt{2}}{\sqrt{3}-1}$ | $\frac{2\sqrt{2}}{\sqrt{3}+1}$ |
| Sec | 1 | $\frac{2}{\sqrt{3}}$ | $\sqrt{2}$ | 2 | ∞ | $\frac{2\sqrt{2}}{\sqrt{3}+1}$ | $\frac{2\sqrt{2}}{\sqrt{3}-1}$ |
| Cot | ∞ | $\sqrt{3}$ | 1 | $\frac{1}{\sqrt{3}}$ | 1 | $\frac{1}{2-\sqrt{3}}$ | $\frac{1}{2+\sqrt{3}}$ |

1. Sine Rule

$$\frac{a}{\sin A} = \frac{b}{\sin B} = \frac{c}{\sin C} = 2R$$

where R is circumradius of the triangle

2. Cosine Rule

$$\cos A = \frac{b^2 + c^2 - a^2}{2bc}; \quad \cos B = \frac{c^2 + a^2 - b^2}{2ca}; \quad \cos C = \frac{a^2 + b^2 - c^2}{2ab}$$

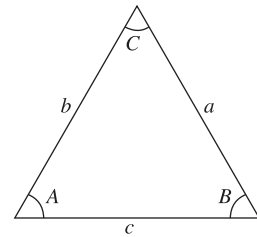
**3. Projection Rule**

$$a = b \cos C + c \cos B; \quad b = c \cos A + a \cos C; \quad c = a \cos B + b \cos A$$

4. Law of tangents

In any triangle ABC,

$$\frac{a-b}{a+b} = \frac{\tan\left(\frac{A-B}{2}\right)}{\tan\left(\frac{A+B}{2}\right)}; \quad \frac{c-a}{c+a} = \frac{\tan\left(\frac{C-A}{2}\right)}{\tan\left(\frac{C+A}{2}\right)}; \quad \frac{b-c}{b+c} = \frac{\tan\left(\frac{B-C}{2}\right)}{\tan\left(\frac{B+C}{2}\right)}$$

5. Expression for half angles in terms of a , b and c

$$\sin\left(\frac{A}{2}\right) = \sqrt{\frac{(s-b)(s-c)}{bc}}; \quad \cos\left(\frac{A}{2}\right) = \sqrt{\frac{s(s-a)}{bc}}; \quad \tan\left(\frac{A}{2}\right) = \sqrt{\frac{(s-b)(s-c)}{s(s-a)}}$$

338 ANNEXURE 1: USEFUL RELATIONSHIPS

6. Inverse Functions

If $y = \sin^{-1} x$, then $x = \sin y$

$$\cos y = \sqrt{1-x^2}$$

$$y = \cos^{-1} \sqrt{1-x^2}$$

$$\tan y = \frac{x}{\sqrt{1-x^2}}$$

o r

$$y = \tan^{-1} \left[\frac{x}{\sqrt{1-x^2}} \right]$$

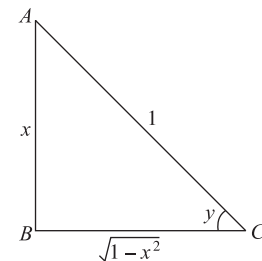

7. Algebra

$$(a+b)^2 = a^2 + b^2 + 2ab; \quad (a-b)^2 = a^2 + b^2 - 2ab;$$

$$(a+b)^3 = a^3 + b^3 + 3ab(a+b); \quad (a-b)^3 = a^3 - b^3 - 3ab(a-b)$$

Laws of indices:

$$a^m a^n = a^{m+n}; \quad \frac{a^m}{a^n} = a^{m-n}; \quad [a^m]^n = a^{mn}$$

$$[ab]^n = a^n b^n; \quad \left[\frac{a}{b} \right]^n = \frac{a^n}{b^n}; \quad a^0 = 1$$

$$\log_a uv = \log_a u + \log_a v; \quad \log_a \left[\frac{u}{v} \right] = \log_a u - \log_a v;$$

$$\log_a u^m = m \log_a u; \quad \log_b u = \frac{\log_a u}{\log_a b}$$

Sum of n terms of an Arithmetic Progression,

$$S_n = 1 + 2 + 3 + \dots + n = \frac{n}{2}(a+1)$$

Sum of first n terms of a Geometric Progression

$$S_n = \frac{a(1-r^n)}{(1-r)} \quad \text{or} \quad \frac{a(r^n-1)}{(r-1)}$$

Roots of quadratic equation $ax^2 + bx + c = 0$ is given by $x = \frac{-b \pm \sqrt{b^2 - 4ac}}{2a}$.

8. Calculus

$$\frac{d}{dx}(x^n) = nx^{n-1}; \quad \frac{d}{dx}(\text{constant}) = 0; \quad \text{If } y = u \pm v, \quad \frac{dy}{dx} = \frac{du}{dx} \pm \frac{dv}{dx}$$

$$\text{if } y = \sqrt{x}, \frac{dy}{dx} = \frac{1}{2\sqrt{x}}; \text{ if } y = uv, \frac{dy}{dx} = u \frac{dv}{dx} + v \frac{du}{dx}; \text{ if } y = \frac{u}{v}, \frac{dy}{dx} = \frac{v \frac{du}{dx} - u \frac{dv}{dx}}{v^2}$$

$$\begin{aligned} d(\sin x) &= \cos x; & d(\cos x) &= -\sin x; & d(\tan x) &= \sec^2 x \\ d(\cot x) &= -\operatorname{cosec} x; & d(\sec x) &= \sec x \tan x; & d(\operatorname{cosec} x) &= \operatorname{cosec} x \cot x \end{aligned}$$

$$\text{if } y = e^x, \frac{dy}{dx} = e^x; \text{ if } y = \log_e x, \frac{dy}{dx} = \frac{1}{x}; \text{ if } y = e^{ax}, \frac{dy}{dx} = ae^{ax}$$

$$\int a dx = ax; \int x^n dx = \frac{x^{n+1}}{n+1}; \int \frac{dx}{x} = \log x; \int e^x dx = e^x; \int a^x dx = \frac{a^x}{\log a}$$

$$\int \sin x dx = -\cos x; \int \cos x dx = \sin x; \int \sec^2 x dx = \tan x; \int \operatorname{cosec}^2 x dx = -\cot x;$$

$$\int \tan x \sec x dx = \sec x; \int \operatorname{cosec} x \cot x dx = -\operatorname{cosec} x;$$

$$\int \tan x dx = \log \sec x = -\log \cos x$$

9. Trigonometric Relationships

(i) Reduction formulae

$$\begin{aligned} \sin(-\alpha) &= -\sin \alpha & \cos(-\alpha) &= \cos \alpha & \tan(-\alpha) &= -\tan \alpha \\ \sin(180 \pm \alpha) &= \mp \sin \alpha & \sin(90 \pm \alpha) &= +\cos \alpha & \tan(180 \pm \alpha) &= \pm \tan \alpha \\ \cos(180 \pm \alpha) &= -\cos \alpha & \cos(90 \pm \alpha) &= \mp \sin \alpha & \tan(90 \pm \alpha) &= \mp \cot \alpha \end{aligned}$$

(ii) Addition and subtraction formulae

$$\begin{aligned} \sin(\alpha + \beta) &= \sin \alpha \cos \beta + \cos \alpha \sin \beta & \sin(\alpha - \beta) &= \sin \alpha \cos \beta - \cos \alpha \sin \beta \\ \cos(\alpha + \beta) &= \cos \alpha \cos \beta - \sin \alpha \sin \beta & \cos(\alpha - \beta) &= \cos \alpha \cos \beta + \sin \alpha \sin \beta \\ \tan(\alpha + \beta) &= \frac{\tan \alpha + \tan \beta}{1 - \tan \alpha \tan \beta} & \tan(\alpha - \beta) &= \frac{\tan \alpha - \tan \beta}{1 + \tan \alpha \tan \beta} \end{aligned}$$

(iii) Double angle and half angle formulae

$$\begin{aligned} \sin 2\alpha &= 2 \sin \alpha \cos \alpha \\ \tan 2\alpha &= \frac{2 \tan \alpha}{1 - \tan^2 \alpha} \\ \cos 2\alpha &= \cos^2 \alpha - \sin^2 \alpha = 1 - 2 \sin^2 \alpha = 2 \cos^2 \alpha - 1 \\ \sin\left(\frac{\alpha}{2}\right) &= \pm \sqrt{\frac{1 - \cos \alpha}{2}} \\ \cos\left(\frac{\alpha}{2}\right) &= \pm \sqrt{\frac{1 + \cos \alpha}{2}} \\ \tan\left(\frac{\alpha}{2}\right) &= \pm \sqrt{\frac{1 - \cos \alpha}{1 + \cos \alpha}} = \frac{\sin \alpha}{1 + \cos \alpha} = \frac{1 - \cos \alpha}{\sin \alpha} \end{aligned}$$

340 ANNEXURE 1: USEFUL RELATIONSHIPS

(iv) *Reducing trigonometric expressions*

$$\sin \alpha + \sin \beta = 2 \sin \left(\frac{\alpha + \beta}{2} \right) \cos \left(\frac{\alpha - \beta}{2} \right)$$

$$\sin \alpha - \sin \beta = 2 \cos \left(\frac{\alpha + \beta}{2} \right) \sin \left(\frac{\alpha - \beta}{2} \right)$$

$$\cos \alpha + \cos \beta = 2 \cos \left(\frac{\alpha + \beta}{2} \right) \cos \left(\frac{\alpha - \beta}{2} \right)$$

$$\cos \alpha - \cos \beta = -2 \sin \left(\frac{\alpha + \beta}{2} \right) \sin \left(\frac{\alpha - \beta}{2} \right)$$

$$\cos \alpha + \sin \beta = \sqrt{2} \cos (45 - \alpha)$$

$$\cos \alpha - \sin \beta = \sqrt{2} \sin (45 - \alpha)$$

$$\tan \alpha \pm \tan \beta = \frac{\sin (\alpha \pm \beta)}{\cos \alpha \cos \beta}$$

$$1 + \cos \alpha = 2 \cos^2 \left(\frac{\alpha}{2} \right)$$

$$1 - \cos \alpha = 2 \sin^2 \left(\frac{\alpha}{2} \right)$$

$$1 + \sin \alpha = 2 \cos^2 \left(45 - \frac{\alpha}{2} \right)$$

$$1 - \sin \alpha = 2 \sin^2 \left(45 - \frac{\alpha}{2} \right)$$

$$1 \pm \tan \alpha = \frac{\sqrt{2} \sin (45 \pm \alpha)}{\cos \alpha}$$

$$1 \pm \tan \alpha \tan \beta = \frac{\cos (\alpha \mp \beta)}{\cos \alpha \cos \beta}$$

$$1 - \tan^2 \alpha = \frac{\cos 2\alpha}{\cos^2 \alpha}$$

$$\tan^2 \alpha - \tan^2 \beta = \frac{\sin (\alpha + \beta) \sin (\alpha - \beta)}{\cos^2 \alpha \cos^2 \beta}$$

$$\sin \alpha \sin \beta = \frac{1}{2} [\cos (\alpha - \beta) - \cos (\alpha + \beta)]$$

$$\cos \alpha \cos \beta = \frac{1}{2} [\cos (\alpha - \beta) + \cos (\alpha + \beta)]$$

$$\sin \alpha \cos \beta = \frac{1}{2} [\sin (\alpha - \beta) + \sin (\alpha + \beta)]$$

$$\sin \alpha = \frac{2 \tan \left(\frac{\alpha}{2} \right)}{1 + \tan^2 \left(\frac{\alpha}{2} \right)}; \quad \cos \alpha = \frac{1 - \tan^2 \left(\frac{\alpha}{2} \right)}{1 + \tan^2 \left(\frac{\alpha}{2} \right)}; \quad \tan \alpha = \frac{2 \tan \left(\frac{\alpha}{2} \right)}{1 - \tan^2 \left(\frac{\alpha}{2} \right)}$$

ANNEXURE 2

ELEMENTS OF CIVIL ENGINEERING AND MECHANICS (4:0:0)

Sub Code: 14CV13/23
Hrs/week: 4+0+0
Total Hours: 50

Internal Marks: 25
Exam Marks: 100

COURSE OUTCOMES

After a successful completion of the course, the student will be able to:

- (a) Know basics of Civil Engineering, its scope of study, knowledge about Roads, Bridges and Dams.
- (b) Comprehend the action of Forces, Moments and other loads on systems of rigid bodies.
- (c) Compute the reactive forces and the effects that develop as a result of the external loads.
- (d) Express the relationship between the motion of bodies.
- (e) Equipped to pursue studies in allied courses in Mechanics.

PARTICULARS

Hours

| | |
|--|-----------|
| Module 1: Introduction to Civil Engineering and Engineering Mechanics | 10 |
| Introduction to Civil Engineering, Scope of different fields of Civil Engineering— Surveying, Building Materials, Construction Technology, Geotechnical Engineering, Structural Engineering, Hydraulics, Water Resources and Irrigation Engineering, Transportation Engineering, Environmental Engineering. | 01 |
| Infrastructure: Types of infrastructure, Role of Civil Engineer in the Infrastructural Development, Effect of the infrastructural facilities on socio-economic development of a country. | 01 |
| Roads: Classification of Roads and their functions, Comparison of Flexible and Rigid Pavements (Advantages and Limitations). | 01 |
| Bridges: Types of Bridges and Culverts, RCC, Steel and Composite Bridges. | 01 |

342 ANNEXURE 2: ELEMENTS OF CIVIL ENGINEERING AND MECHANICS (4:0:0)

| | |
|--|-----------|
| Dams: Different types of Dams based on Material, Structural behavior and functionality with simple sketches. | 01 |
| Introduction to Engineering Mechanics | |
| Basic idealizations—Particle, Continuum and Rigid body; Force and its characteristics, types of forces, Classification of force systems; Principle of physical independence of forces, Principle of superposition of forces, Principle of transmissibility of forces; Newton’s laws of motion, Introduction to SI units. | 02 |
| Couple, Moment of a couple, Characteristics of couple, Moment of a force, Equivalent force—Couple system; Numerical problems on moment of forces and couples, on equivalent force—couple system. | 02 |
| Module 2: Analysis of Force Systems—Concurrent and Non-concurrent System | 10 |
| Concurrent Force System | |
| Composition of forces—Definition of Resultant; Composition of coplanar—concurrent force system, Parallelogram Law of forces, Principle of resolved parts; Numerical problems on composition of coplanar concurrent force systems. | 04 |
| Non-concurrent Force System | |
| Composition of coplanar—non-concurrent force system, Varignon’s principle of moments; Numerical problems on composition of coplanar non-concurrent force system. | 06 |
| Module 3: Equilibrium of Forces and Friction | 10 |
| Equilibrium of Concurrent and Non-concurrent Forces | |
| Equilibrium of forces—Definition of Equilibrant; Conditions of static equilibrium for different force systems, Lami’s theorem; Numerical problems on equilibrium of coplanar—concurrent and non-concurrent force systems. | 03 |
| Support Reaction | |
| Types of Loads and Supports, Statically determinate beams, Numerical problems on support reactions for statically determinate beams with Point load (Normal and inclined) and uniformly distributed loads. | 03 |
| Friction | |
| Definitions: Types of friction, Laws of static friction, Limiting friction, Angle of friction, angle of repose; Impending motion on horizontal and inclined planes; Numerical Problems on single and two blocks on inclined planes. | 02 01 |
| Numerical problems on Ladder and Wedge friction. | 01 |

Module 4: Centroid and Moment of Inertia of Engineering Sections 10

Centroids

Introduction to the concept, centroid of line and area, centroid of basic geometrical figures, computing centroid for composite lines and Engineering composite sections—T, L, I and Z sections and their built up sections. Numerical problems. 05

Moment of Inertia

Introduction to the concept, Radius of gyration, Parallel axis theorem, Perpendicular axis theorem, Moment of Inertia of basic planar figures, computing moment of Inertia for Engineering composite sections—T, L, I and Z sections and their built up sections. Numerical problems. 05

Module 5: Kinematics 10

Definitions – Displacement – Average velocity – Instantaneous velocity – Speed – Acceleration – Average acceleration – Variable acceleration – Acceleration due to gravity – Newton’s Laws of Motion. 02

Rectilinear Motion – Numerical problems. 02

Curvilinear Motion – Super elevation – Projectile Motion – Relative motion – Numerical problems. 03

Motion under gravity – Numerical problems. 03

Textbooks

1. *Elements of Civil Engineering and Engineering Mechanics* by M.N. Shesha Prakash and Ganesh B. Mogaveer, PHI Learning, 3rd Revised edition, 2014.
2. *Engineering Mechanics—Statics and Dynamics* by A Nelson, Tata McGraw-Hill Education, New Delhi, 2009.
3. *Elements of Civil Engineering*, 4th ed., by S.S. Bhavikatti, New Age International Publisher, New Delhi, 3rd edition, 2009.

References

1. *Engineering Mechanics* by S. Timoshenko, D.H. Young, and J.V. Rao, Tata McGraw-Hill, New Delhi.
2. Beer, FP and Johnson, ER, *Mechanics for Engineers—Dynamics and Statics*, 3rd SI Metric edition, Tata McGraw-Hill, 2008.
3. Shames IH, *Engineering Mechanics—Statics and Dynamics*, PHI Learning, 2009.

OBJECTIVE TYPE QUESTIONS

Chapter 1: INTRODUCTION TO CIVIL ENGINEERING

1. Geotechnical engineering involves the study of _____.
(a) Water (b) **Soil** (c) Air (d) All of these
2. By-pass road is constructed _____.
(a) Inside the city (b) Over the main road
(c) **Around the city** (d) None of these
3. The part of civil engineering which deals with waste water and solid waste is called _____.
(a) Water supply engineering (b) Geotechnical engineering
(c) **Sanitary engineering** (d) Structural engineering
4. A bascule bridge is a _____.
(a) Floating bridge (b) Arch bridge
(c) Suspension bridge (d) **Movable bridge**
5. A branch of civil engineering dealing with the technical measures to use and protect the components of environment is _____.
(a) Transportation engineering (b) Hydraulics engineering
(c) Geotechnical engineering (d) **Environmental engineering**
6. A bridge constructed at some angle to river flow is _____.
(a) **Skew bridge** (b) Square bridge
(c) Steel bridge (d) Lift bridge
7. The part of civil engineering which deals with design of slabs, beams columns footings etc. is called _____.
(a) Transportation engineering (b) **Structural engineering**
(c) Geotechnical engineering (d) Water supply engineering
8. An effect of pollution and reducing the ill-effects is studied under _____.
(a) Surveying (b) Geotechnical engineering
(c) Hydraulics (d) **Environmental engineering**

346 OBJECTIVE TYPE QUESTIONS

9. River flood controlling can be done by constructing
(a) Bridge (b) Tunnel (c) **Dam** (d) Harbour
10. Long span bridges are generally made of _____.
(a) Plain cement concrete (b) **Pre-stressed concrete**
(c) Timber (d) Pozzolona concrete
11. _____ is used for flood control, navigation and hydropower generation.
(a) **Multipurpose dam** (b) Detention dam
(c) Timber dam (d) Culvert
12. Which of the following is not a term related to bridge?
(a) Approach (b) Pier
(c) **Impervious core** (d) Abutment
13. _____ are constructed on both sides of abutments to prevent scouring for protecting the banks of river.
(a) **Wing walls** (b) Dams (c) Piers (d) Trusses
14. For crossing a water course or valley in all seasons _____ is essential.
(a) Pathways (b) Flooring (c) **Bridge** (d) Curb
15. Use of _____ is essential for saving time labour, money, etc. during a work.
(a) **Construction technology** (b) Arch bridge
(c) Pipe culvert (d) Gravity dam
16. Composite material consisting of cement concrete and steel used in civil engineering structural construction is _____.
(a) Prestressed Concrete (PSC) (b) **Reinforced Cement Concrete (RCC)**
(c) Fibre Reinforced Concrete (FRC) (d) Plain Cement Concrete (PCC)
17. Highway which are superior to national highways and are provided wherever volume of traffic is very high are _____.
(a) State highway (b) Roadways (c) Airways (d) **Expressways**
18. Studying of the properties of soil in assessing safe bearing capacity is called as _____.
(a) Transportation engineering (b) Building materials
(c) Estimation (d) **Geotechnical engineering**
19. Building tanks and dams and carrying stored water to field is known as _____.
(a) Structural engineering
(b) Environmental engineering
(c) **Water resource & irrigation engineering**
(d) Construction technology
20. Kerbs are the components of _____.
(a) **Roads** (b) Bridges (c) Building (d) Dam
21. Reinforced cement concrete (RCC) comes under _____.
(a) Architecture & town planning (b) Hydraulics
(c) Surveying (d) **Structural engineering**

22. The science of map making is known as _____.
- (a) Estimation (b) **Surveying**
(c) Town planning (d) Construction technology
23. The structure which provides passage over the obstacles like valley, river without closing the way underneath is _____.
- (a) Dam (b) **Bridge** (c) Harbour (d) Airport
24. Pick up a structure in which a inspection gallery is formed
- (a) **Gravity dam** (b) Bridge (c) Harbour (d) Airport

Chapter 2: INTRODUCTION TO ENGINEERING MECHANICS

1. A particle can have _____.
- (a) **Only translational motion**
(b) Only rotational motion
(c) A combination of translational and rotational motions
(d) All the above types of motion
2. A scalar quantity has _____.
- (a) **Only magnitude** (b) Only direction
(c) Both magnitude and direction (d) Neither magnitude nor direction
3. A vector quantity has _____.
- (a) Only magnitude (b) Only direction
(c) **Both magnitude and direction** (d) Neither magnitude nor direction
4. Moment of a force can be defined as the product of force and _____ distance from the line of action of force to the moment centre
- (a) **Least** (b) Maximum (c) Any (d) None of these
5. Effect of force on a body depends on _____.
- (a) Direction (b) Magnitude (c) Position (d) **All of these**
6. The forces which meet at one point and have their lines of action in different planes are called _____.
- (a) Coplanar concurrent forces (b) **Non-coplanar concurrent forces**
(c) Non-coplanar non-concurrent forces (d) None of these
7. Couple means two forces acting parallel, _____.
- (a) Equal in magnitude and in the same direction
(b) Not equal in magnitude but in the same direction
(c) **Equal in magnitude, but opposite in direction**
(d) None of the above
8. Moment of a force about a moment centre is the measure of its _____.
- (a) Translatory effect (b) Rotational effect
(c) **Both a and b** (d) None of these

348 OBJECTIVE TYPE QUESTIONS

9. The translatory effect of a couple on the rigid body is _____.
(a) Positive (b) Negative (c) **Zero** (d) None of these
10. Principle of transmissibility of forces states that when a force acts upon a body, its effect is _____.
(a) Minimum if it acts at the C.G. of the body
(b) Maximum if it acts at the C.G. of the body
(c) **Same at every point on its line of action**
(d) Different at different points on its line of action
11. Two parallel forces equal in magnitude and opposite in direction and separated by a finite distance are said to form _____.
(a) Moment (b) **Couple** (c) Resultant (d) Equilibrant
12. Couple is a _____.
(a) **Free vector** (b) Sliding vector (c) Fixed vector (d) Unit vector
13. Force can be resolved into _____.
(a) Only one component (b) Only two components
(c) Only three components (d) **Any number of components**
14. The magnitude of the moment is _____ when a force is applied perpendicular to a lever
(a) **Maximum** (b) Minimum (c) Zero (d) Negative
15. The component of force is always _____.
(a) Less than its magnitude (b) Greater than its magnitude
(c) Equal to its magnitude (d) **None of these**
16. The net force that results from a number of individual forces acting on an object is the vector sum of the individual forces. This is termed as the _____.
(a) **Principle of superposition** (b) Principle of transmissibility
(c) Moment of forces (d) Principle of physical independence
17. An object regarded as only mass but no size in mechanics is _____.
(a) Point force (b) Rigid body
(c) Deformable body (d) **Particles**
18. The term 'force' may be defined as an agent which produces or tends to produce, destroy or tends to destroy motion.
(a) **Agree** (b) Disagree
19. A force while acting on a body may
(a) Change its motion (b) Balance the forces, already acting on it
(c) Give rise to the internal stresses in it (d) **All of these**
20. The unit of the force in S.I. system of units is
(a) Dyne (b) Kilogram (c) **Newton** (d) Watt
21. One kg force is equal to
(a) 7.8 N (b) 8.9 N (c) **9.8 N** (d) 12 N

22. The algebraic sum of the resolved parts of a number of forces in a given direction is equal to the resolved part of their resultant in the same direction. This is known as
 (a) Principle of independence of forces (b) **Principle of resolution of forces**
 (c) Principle of transmissibility of forces (d) None of these
23. The moment of a force
 (a) Is the turning effect produced by a force, on the body, on which it acts
 (b) Is equal to the product of force acting on the body and the perpendicular distance of a point and the line of action of the force
 (c) Is equal to twice the area of the triangle, whose base is the line representing the force and whose vertex is the point, about which the moment is taken
 (d) **All of the above**
24. Three forces acting on a rigid body are represented in magnitude, direction and line of action by the three sides of a triangle taken in order. The forces are equivalent to a couple whose moment is equal to
 (a) Area of the triangle (b) **Twice the area of the triangle**
 (c) Half the area of the triangle (d) None of these
25. Two equal and opposite parallel forces whose lines of action are different form a couple.
 (a) **Right** (b) Wrong
26. A couple produces
 (a) Translatory motion (b) **Rotational motion**
 (c) Combined translatory and rotational motion
 (d) None of the above
27. Which of the following statement is correct?
 (a) The algebraic sum of the forces, constituting the couple is zero
 (b) The algebraic sum of the forces, constituting the couple, about any point is the same
 (c) A couple cannot be balanced by a single force but can be balanced only by a couple of opposite sense
 (d) **All of the above**
28. The resultant of two forces each equal to P acting at right angles is
 (a) $\frac{P}{\sqrt{2}}$ (b) $\frac{P}{2}$ (c) $\frac{P}{2\sqrt{2}}$ (d) $\sqrt{2}P$
29. The resultant of two forces is P and Q is R . If Q is doubled, the new resultant is perpendicular to P . Then
 (a) $P = Q$ (b) $Q = R$ (c) $Q = 2R$ (d) None of these
30. Two forces are acting at an angle of 120° . The bigger force is 40 N and the resultant is perpendicular to the smaller force. The smaller force is
 (a) **20 N** (b) 40 N (c) 80 N (d) None of these
31. If three forces of 100 N, 200 N and 300 N have their line of action parallel to each other, but act in the opposite directions. These forces are known as
 (a) Coplanar concurrent forces (b) Coplanar non concurrent forces
 (c) Like parallel forces (d) **Unlike parallel forces**

350 OBJECTIVE TYPE QUESTIONS

32. Two like parallel forces are acting at a distance of 24 mm apart and their resultant is 20 N. If the line of action of the resultant is 6 mm from any given force, the two forces are
(a) **15 N and 5 N** (b) 20 N and 5 N (c) 15 N and 15 N (d) None of these
33. Moment of a force about a point can be represented by
(a) Area of triangle
(b) Area of quadrilateral
(c) **Twice the Area of triangle**
(d) Moment cannot be represented by any geometrical figures
34. The moment of the resultant of the system of forces about three non collinear points is zero. This statement signifies
(a) The moment of the resultant about all the three points is same
(b) The three points cannot be a non collinear
(c) **The resultant of the forces is zero**
(d) None of the above
35. The moment of a couple is called
(a) Torque (b) Torsion (c) **Both (a) and (b)** (d) None of these
36. In determining the position of point of action of the resultant of system of coplanar non concurrent forces the diagram drawn is called
(a) **Funicular polygon** (b) Space diagram
(c) Vector diagram (d) None of these
37. A smooth cylinder lying on a _____ is in neutral equilibrium.
(a) Curved surface (b) Convex surface
(c) **Horizontal surface**
38. Two equal and opposite parallel forces whose line of action are different, can be replaced by a single force parallel to the given forces.
(a) Correct (b) **Incorrect**

**Chapter 3: COPLANAR CONCURRENT FORCE SYSTEM
and
Chapter 4: COPLANAR NON-CONCURRENT FORCE SYSTEM**

1. The technique of finding the resultant of a system of forces is called _____.
(a) Resultant (b) Resolution (c) **Composition** (d) None of these
2. If two forces P and Q ($P > Q$) act on the same straight line but in opposite direction, their resultant is _____.
(a) $P + Q$ (b) $\frac{P}{Q}$ (c) $Q - P$ (d) $P - Q$
3. Component of a force at right angles to its line of action is _____.
(a) **Zero** (b) Positive (c) Negative (d) None of these

4. If two concurrent forces each of magnitude P act at right angles to each other, their resultant is _____.
- (a) $2P$ (b) P (c) $P\sqrt{2}$ (d) $2\sqrt{P}$
5. A rigid body acted upon by coplanar non-concurrent force system has _____.
- (a) Both translatory and rotary motion
 (b) Translatory motion in one direction and rotary motion about itself
 (c) Under rest completely
 (d) **All of the above**
6. If the resultant of coplanar concurrent force system acts along horizontal X-axis, then _____.
- (a) $\Sigma F_x = 0$ (b) $\Sigma F_x = R$ (c) $\Sigma F_y = R$ (d) None of these
7. Varignon's theorem is not applicable for forces which are _____.
- (a) Coplanar non-concurrent (b) Non-coplanar non-concurrent
 (c) **Concurrent** (d) Parallel
8. The magnitudes of two given forces are 40 N and 60 N. Which of the following cannot be their resultant?
- (a) 20 N (b) 30 N (c) 40 N (d) **120 N**
9. If magnitude of the resultant of two forces of magnitudes P and P is p , the angle between the two forces is _____.
- (a) 60° (b) 30° (c) 45° (d) **120°**
10. In coplanar concurrent force system if $\Sigma H = 0$, then the resultant is _____.
- (a) Horizontal (b) **Vertical** (c) Moment (d) None of these
11. The single force which will have the same effect as the system of force is _____.
- (a) Couple (b) **Resultant** (c) Moment (d) Force
12. The simplest resultant of a parallel force system is always _____.
- (a) A wrench (b) **A force**
 (c) A moment (d) A force and a moment
13. The purpose of replacing a number of forces acting on a body simultaneously is _____.
- (a) To find resolution (b) To find transmission
 (c) **To find resultant** (d) To find moment of forces
14. If two forces act at an angle of 120° , the greater force is 50 N and their resultant is perpendicular to the smaller force is _____.
- (a) 20 N (b) **25 N** (c) 30 N (d) 43.33 N
15. The resultant of two forces of two concurrent forces becomes maximum and minimum if angle between them is _____.
- (a) **0° and 180°** (b) 0° and 90° (c) 90° and 0° (d) None of these
16. The resultant of force system shown in figure
- (a) 65 N (b) 40 N (c) **76.32 N** (d) 32.76 N

352 OBJECTIVE TYPE QUESTIONS

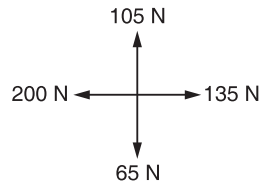

17. The forces which pass through a single point and lie in the same plane are _____.
- (a) Collinear forces (b) Coplanar non-concurrent forces
(c) **Coplanar concurrent forces** (d) None of these
18. Forces co-exist on a plane and all the forces act-helter –skelter over the body. These are _____.
- (a) **Coplanar non-concurrent forces** (b) Coplanar concurrent forces
(c) Coplanar parallel forces (d) Non-coplanar non-concurrent forces
19. Forces whose lines of action lie along the same lines are _____.
- (a) Coplanar parallel forces (b) **Collinear forces**
(c) Coplanar concurrent forces (d) Coplanar non-concurrent forces
20. A resultant force is a single force which produces the same effect as produced by all the given forces acting on a body.
- (a) **True** (b) False
21. The process of finding out the resultant force is called _____ of forces.
- (a) **Composition** (b) Resolution
22. The resultant of two forces P and Q acting at an angle θ is
- (a) $\sqrt{P^2 + Q^2 + 2PQ \sin \theta}$ (b) $\sqrt{P^2 + Q^2 + 2PQ \cos \theta}$
(c) $\sqrt{P^2 + Q^2 - 2PQ \cos \theta}$ (d) $\sqrt{P^2 + Q^2 - 2PQ \tan \theta}$
23. If the resultant of two forces P and Q acting at an angle θ , make an angle α with the force P , then
- (a) $\tan \alpha = \frac{P \sin \theta}{P + Q \cos \theta}$ (b) $\tan \alpha = \frac{P \cos \theta}{P + Q \cos \theta}$
(c) $\tan \alpha = \frac{Q \sin \theta}{P + Q \cos \theta}$ (d) $\tan \alpha = \frac{Q \cos \theta}{P + Q \sin \theta}$
24. The resultant of two equal forces P making an angle θ , is given by
- (a) $2P \sin \frac{\theta}{2}$ (b) $2P \cos \frac{\theta}{2}$ (c) $2P \tan \frac{\theta}{2}$ (d) $2P \cot \frac{\theta}{2}$
25. The angle between two forces when the resultant is maximum and minimum respectively are
- (a) 0° and 180° (b) 180° and 0° (c) 90° and 180° (d) 90° and 0°
26. If the resultant of two equal forces has the same magnitude as either of the forces, then the angle between the two forces is
- (a) 30° (b) 60° (c) 90° (d) **120°**

27. If a number of forces are acting at a point, their resultant will be inclined at an angle θ with the horizontal such that
- (a) $\tan \theta = \frac{\Sigma H}{\Sigma V}$ (b) $\tan \theta = \frac{\Sigma V}{\Sigma H}$
 (c) $\tan \theta = \Sigma V \times \Sigma H$ (d) $\tan \theta = \sqrt{\Sigma V + \Sigma H}$
28. Concurrent forces are those forces whose lines of action
- (a) Lie on the same line (b) **Meet at one point**
 (c) Meet on the same plane (d) None of these
29. If the resultant of a number of forces acting on a body is zero, then the body will not be in equilibrium.
- (a) Yes (b) **No**
30. The forces which do not meet at one point, but their lines of action lie on the same plane, are known as coplanar concurrent forces.
- (a) **Agree** (b) Disagree
31. The forces which meet at one point, but their lines of action _____ on the same plane, are known as non-coplanar concurrent forces.
- (a) Lie (b) **Do not lie**
32. The forces which do not meet at one point and their lines of action do not lie on the same plane, are known as
- (a) Coplanar concurrent forces (b) Coplanar non-concurrent forces
 (c) Non-coplanar concurrent forces (d) **None of these**
33. Coplanar non-concurrent forces are those forces which _____ at one point, but their lines of action lie on the same plane.
- (a) Meet (b) **Do not meet**
34. Non-coplanar concurrent forces are those forces which
- (a) **Meet at one point, but their lines of action do not lie on the same plane**
 (b) Do not meet at one point and their lines of action do not lie on the same plane
 (c) Meet at one point and their lines of action also lie on the same plane
 (d) Do not meet at one point, but their lines of action lie on the same plane
35. Vectors method for the resultant force is also called polygon law of forces
- (a) Correct (b) Incorrect
36. Non-coplanar concurrent forces are those forces which
- (a) Meet at one point, but their lines of action do not lie on the same plane
 (b) **Do not meet at one point and their lines of action do not lie on the same plane**
 (c) Do not meet at one point, but their lines of action lie on the same plane
 (d) None of the above
37. If a number of coplanar forces acting at a point be in equilibrium, the sum of clockwise moments must be _____ the sum of anticlockwise moments, about any point.
- (a) **Equal to** (b) Less than (c) Greater than

354 OBJECTIVE TYPE QUESTIONS

38. Varignon's theorem of moments states that if a number of coplanar forces acting on a particle are in equilibrium, then
- (a) Their algebraic sum is zero
 - (b) Their lines of action are at equal distances
 - (c) The algebraic sum of their moments about any point in their plane is zero
 - (d) **The algebraic sum of their moments about any point is equal to the moment of their resultant force about the same point**
39. According to the law of moments, if a number of coplanar forces acting on a particle are in equilibrium, then
- (a) Their algebraic sum is zero
 - (b) Their lines of action are at equal distances
 - (c) **The algebraic sum of their moments about any point in their plane is zero**
 - (d) The algebraic sum of their moments about any point is equal to the moment of their resultant force about the same point
40. The forces, whose lines of action are parallel to each other and act in the same directions, are known as
- (a) Coplanar concurrent forces
 - (b) Coplanar non-concurrent forces
 - (c) **Like parallel forces**
 - (d) Unlike parallel forces
41. If a body is acted upon by a number of coplanar non-concurrent forces, it may
- (a) Rotate about itself without moving
 - (b) Move in any one direction rotating about itself
 - (c) Be completely at rest
 - (d) **All of these**
42. Varignon's theorem is applicable only to
- (a) Coplanar concurrent forces
 - (b) Coplanar non concurrent forces
 - (c) **Both (a) and (b)**
 - (d) Forces lying in different planes
43. If a body is in equilibrium under the action of several forces, then the algebraic sum of moments of these forces about any point in their plane is zero, the above statement is called
- (a) **Principle of moments**
 - (b) Varignon's theorem
 - (c) Theorem of moments
 - (d) None of these

Chapter 5: EQUILIBRIUM OF COPLANAR CONCURRENT FORCE SYSTEM

1. The necessary condition for equilibrium of a coplanar concurrent force system is that algebraic sum of _____ must be zero.
- (a) **Horizontal and vertical forces**
 - (b) Moment of forces
 - (c) Horizontal, vertical forces and moments
 - (d) None of the above
2. In non-concurrent force system if $\Sigma H = 0$ and $\Sigma V = 0$ then the resultant is _____.
- (a) Resultant force
 - (b) Force
 - (c) **Moment**
 - (d) Zero

3. The force which is equal and opposite to the resultant is _____.
 - (a) Resultant force
 - (b) Force
 - (c) **Equilibrant**
 - (d) None of these
4. The procedure of resolution is _____.
 - (a) To find the resultant of the force system
 - (b) **To break up an inclined force into two components**
 - (c) To find the equilibrant
 - (d) None of the above
5. A rigid body is in equilibrium if the resultant force of concurrent force system is _____.
 - (a) Positive
 - (b) Negative
 - (c) **Zero**
 - (d) None of these
6. A system of force that possesses resultant force move in _____.
 - (a) **The direction of line of action of resultant**
 - (b) Opposite to the direction of line of action of resultant
 - (c) Perpendicular to the direction of line of action of resultant
 - (d) None of the above
7. Lami's theorem is valid for _____.
 - (a) Two concurrent forces in equilibrium
 - (b) Four concurrent forces in equilibrium
 - (c) **Three concurrent forces in equilibrium**
 - (d) None of the above
8. For a smooth spherical surface reaction acts _____.
 - (a) Horizontal to the plane of contact
 - (b) Inclined to the plane of contact
 - (c) **Perpendicular to the plane of contact**
 - (d) None of the above
9. Lami's equation can be applied when number of unknown forces are _____.
 - (a) **Two**
 - (b) Three
 - (c) Five
 - (d) None of these
10. The necessary condition for equilibrium of coplanar concurrent force system is _____.
 - (a) $\Sigma F_y = \Sigma F_x$
 - (b) **$\Sigma F_x = 0, \Sigma F_y = 0$**
 - (c) $\Sigma m = 0$
 - (d) $\Sigma F_x - \Sigma F_y = 1$
11. A system that possesses a resultant _____.
 - (a) Will be in equilibrium
 - (b) Will be under rest
 - (c) **Will not be in equilibrium**
 - (d) None of these
12. If a body is in equilibrium, we may conclude that _____.
 - (a) No force is acting on the body
 - (b) The resultant of all the forces acting on it is zero
 - (c) The moments of the forces about any point is zero
 - (d) **Both (b) and (c)**
13. If the sum of all the forces acting on a body is zero, then the body may be in equilibrium provided the forces are _____.
 - (a) **Concurrent**
 - (b) Parallel
 - (c) Like parallel
 - (d) Unlike parallel

356 OBJECTIVE TYPE QUESTIONS

14. Three forces acting on a body can keep it in equilibrium, only when they are _____.
- (a) Collinear (b) **Coplanar and concurrent**
(c) Coplanar and parallel (d) Coplanar and non-concurrent
15. A particle acted upon by two forces of equal magnitudes is in equilibrium. The angle between the two forces is _____.
- (a) 0° (b) 90° (c) **180°** (d) 45°
16. Lami's theorem _____.
- (a) Relates the forces with the sines of angles
(b) **Relates the action of three concurrent forces and sines of angles**
(c) May be applied to consider relationship between forces
(d) May be applied for a body which may or may not be in equilibrium
17. A rigid body is in equilibrium under the action of three forces. It implies that the forces must be such that the _____.
- (a) Resultant is zero (b) Equilibrant is zero
(c) **Both (a) and (b)** (d) None of these
18. If sum of all the forces acting on a body is zero, it may be concluded that the body
- (a) **Must be in equilibrium**
(b) Cannot be in equilibrium
(c) May be in equilibrium provided the forces are concurrent
(d) May be in equilibrium provided the forces are parallel
19. The necessary condition of equilibrium of concurrent force system is _____.
- (a) **The algebraic sum of horizontal and vertical forces must be zero**
(b) The algebraic sum of moments of forces must be zero
(c) The algebraic sum of horizontal, vertical and moments of forces must be zero
(d) All of the above
20. Equilibrant is nothing but a resultant _____.
- (a) Equal in magnitude and in the same direction
(b) **Equal in magnitude but opposite in direction**
(c) Not equal in magnitude but in the same direction
(d) Not equal in magnitude and opposite in direction
21. If a given force (or a given system of forces) acting on a body _____ the position of the body, but keeps it in equilibrium, then its effect is to produce internal stress in the body.
- (a) Change (b) **Does not change**
22. If three forces acting at a point are represented in magnitude and direction by the three sides of a triangle, taken in order, then the forces are in equilibrium.
- (a) **Yes** (b) No
23. If a number of forces acting at a point be represented in magnitude and direction by the three sides of a triangle, taken in order, then the forces are not in equilibrium.
- (a) Agree (b) **Disagree**

24. For any system of coplanar forces, the condition of equilibrium is that the
- (a) Algebraic sum of the horizontal components of all the forces should be zero
 - (b) Algebraic sum of the vertical components of all the forces should be zero
 - (c) Algebraic sum of moments of all the forces about any point should be zero
 - (d) **All of the above**
25. If three forces acting at a point be represented in magnitude and direction by the three sides of a triangle, taken in order, the forces shall be in equilibrium.
- (a) **True**
 - (b) False
26. A number of forces acting at a point will be in equilibrium, if
- (a) All forces are equally inclined
 - (b) **Sum of all forces is zero**
 - (c) Sum of resolved parts in the vertical direction is zero
 - (d) Sum of resolved parts in the horizontal direction is zero
27. If three forces acting at a point are in equilibrium, then each force is proportional to the sine of the angle between the other two.
- (a) **Right**
 - (b) Wrong

Chapter 6: EQUILIBRIUM OF COPLANAR NON-CONCURRENT FORCE SYSTEM

1. Statically determinate beams are _____.
- (a) **The beams which can be analyzed completely using equations of equilibrium**
 - (b) The beams which can be analyzed using static equations
 - (c) Fixed beams
 - (d) None of the above
2. Fixed beams are _____.
- (a) One end is fixed and the other is simply supported
 - (b) **Both ends are fixed**
 - (c) Both ends are roller support
 - (d) One end is fixed and the other is free
3. The number of reaction components at fixed end of a beam are _____.
- (a) 2
 - (b) **3**
 - (c) 4
 - (d) None of these
4. Udl stands for _____.
- (a) Uniform dead load
 - (b) **Uniformly distributed load**
 - (c) Uniform door load
 - (d) All of these
5. A reaction line at roller support with respect to plane of contact is _____.
- (a) Oblique
 - (b) Obtuse
 - (c) **Perpendicular**
 - (d) None of these
6. Support reactions for statically determinate beams can be determined by applying _____.
- (a) **Conditions of static equilibrium**
 - (b) Lami's theorem
 - (c) Varignon principle
 - (d) None of these

358 OBJECTIVE TYPE QUESTIONS

7. When load acts at constant rate over given length beam it is called _____.
- (a) Point load (b) **Udl** (c) Uvl (d) None of these
8. A beam having one end hinged support and other roller support subjected to vertical loading can be regarded as _____.
- (a) Fixed beam (b) Cantilever beam
(c) **Simply supported beam** (d) None of these
9. The numbers of reaction components at a hinged end of a beam are _____.
- (a) 0 (b) **2** (c) 3 (d) 1
10. A cantilever beam is one in which _____.
- (a) Both ends are fixed
(b) Both ends are hinged
(c) **One end is fixed and the other is free**
(d) One end is fixed and the other is simply supported
11. At the fixed end of cantilever, number of unknown reaction components are _____.
- (a) 1 (b) 2 (c) **3** (d) 4
12. If one end of beam is fixed and the other is supported by a roller, it is known as _____.
- (a) Cantilever beam (b) Fixed beam
(c) **Propped cantilever beam** (d) Overhanging beam
13. A beam with three or more than three supports is known as _____.
- (a) Cantilever beam (b) Fixed beam
(c) Propped cantilever beam (d) **Continuous beam**
14. A simply supported beam cannot remain in equilibrium if only a _____.
- (a) Inclined force is applied (b) Vertically upward force is applied
(c) Moment is applied (d) **Any of these**
15. The number of equations available for solving a beam supported by rollers at both ends is _____.
- (a) 1 (b) **2** (c) 3 (d) 4
16. A beam is said to be determinate, if
- (a) **The reaction can be determined using the equations of equilibrium**
(b) The reactions cannot be determined using the equations of equilibrium
(c) The reaction can be determined by using the force equilibrium conditions
(d) The reactions can be determined by using the moment equilibrium condition only
17. The beam is neither permitted to move in any direction nor allowed to rotate in the case of _____.
- (a) Hinged support (b) **Fixed support**
(c) Roller support (d) Simple support
18. Uvl stands for _____.
- (a) Uniform vertical load (b) Uniform velocity
(c) Uniform vague load (d) **Uniformly varying load**

19. A thin rigid beam hinged at one end and roller-supported at its mid-point is said to be
- (a) A simply supported beam (b) **A overhanging beam**
 (c) A cantilever beam (d) Fixed beam

Chapter 7: PLANE TRUSSES

- In case of a perfect truss, it satisfies the following expression _____.
 (a) $m < 2j - 3$ (b) $m > 2j - 3$ (c) **$m = 2j - 3$** (d) None of these
- In case of an imperfect truss, _____.
 (a) $m < 2j - 3$ (b) $m > 2j - 3$
 (c) **All the above** (d) None of these
- A framed structure is perfect, if the number of members is _____ ($2j - 3$), where j is the number of joints.
 (a) Less than (b) **Equal to**
 (c) Greater than (d) Either (a) or (c)
- A framed structure is imperfect, if the number of members is _____ ($2j - 3$), where j is the number of joints.
 (a) Less than (b) Equal to
 (c) Greater than (d) **Either (a) or (c)**
- A redundant frame is also called _____ frame.
 (a) Perfect (b) **Imperfect**
 (c) Deficient (d) None of these
- A framed structure of triangular shape is _____.
 (a) **Perfect** (b) Imperfect
 (c) Deficient (d) Redundant
- A truss having four members and four joints and supported by a hinge and a roller is _____.
 (a) **Deficient** (b) Redundant
 (c) Perfect (d) None of these
- The minimum number of members to form a perfect truss is _____.
 (a) 1 (b) 2 (c) **3** (d) 4
- The minimum number of joints in a perfect truss is _____.
 (a) 1 (b) 2 (c) **3** (d) 4
- A joint in a truss has a horizontal member and a vertical member. The joint in the truss is supported by a roller resting on a horizontal surface. Then, _____.
 (a) Vertical member has zero force
 (b) **Horizontal member has zero force**
 (c) Both members have zero force
 (d) Both members have non-zero force

Chapter 8: FRICTION

1. Angle of friction is angle between _____.
(a) The incline and horizontal
(b) The normal reaction and friction force
(c) The weight of the body and the friction here
(d) **Normal reaction and the resultant**
2. The force of friction developed at the contact surface is always _____.
(a) Parallel to the plane and along the direction of the applied force
(b) Perpendicular to the plane
(c) **Parallel to the plane and along the direction of the applied force**
(d) All of the above
3. The maximum inclination of the plane on which the body free from external forces can repose is called _____.
(a) Cone of friction
(b) Angle of friction
(c) **Angle of repose**
(d) None of these
4. The force of friction depend on _____.
(a) Area of contact
(b) **Roughness of the surfaces**
(c) Both areas of contact and roughness of the surfaces
(d) None of the above
5. The maximum frictional force developed when a body just begins to slide over the surface of another body is _____.
(a) Sliding friction
(b) Rolling friction
(c) **Limiting friction**
(d) None of these
6. The angle of which an inclined surface makes with the horizontal when a body placed on it is on the verge of moving down is called _____.
(a) **Angle of repose**
(b) Angle of friction
(c) Angle of inclination
(d) None of these
7. Frictional force is independent of
(a) Coefficient of friction
(b) Angle of friction
(c) **Shape and size of surface of contact**
(d) None of the above
8. Compared to static friction, kinetic friction is _____.
(a) Greater
(b) **Smaller**
(c) Very large
(d) Zero
9. Coefficient of friction (μ) is given by _____.
(a) $\mu = F \cdot R$
(b) $\mu = \frac{F}{R}$
(c) $\mu = \frac{R}{F}$
(d) $\mu = F^2$
10. If Φ = angle of friction and μ = coefficient of friction, then which equation is valid?
(a) **$\tan \Phi = \mu$**
(b) $\tan \Phi = \frac{1}{\mu}$
(c) $\sin \Phi = \mu$
(d) $\cos \Phi = \mu$

11. If Φ = angle of friction and a = angle of repose then which relation is correct.
 (a) $\Phi = \frac{1}{a}$ (b) $\Phi = a$ (c) $\Phi = \tan a$ (d) $a = \tan \Phi$
12. Force of friction developed at contact surface is _____.
 (a) **Opposite to the direction of motion**
 (b) Along to the direction of motion
 (c) Perpendicular to the plane (d) All of the above
13. When a body resting on a rough plane acted upon by gradually increasing tangential force, _____.
 (a) Frictional force is zero
 (b) Frictional force remains constant
 (c) Frictional force increases indefinitely
 (d) **There is a limit up to which frictional force can increase**
14. Frictional force acts _____ the surface in contact.
 (a) **Tangential to** (b) Normal to (c) Inclined to (d) Away from
15. Coulomb's laws of friction can be applied to _____.
 (a) Fluid friction (b) Fluid –structure interaction
 (c) **Dry friction between solid bodies** (d) Lubricated surfaces
16. Impending motion of the body refers to a _____.
 (a) Body at rest (b) **Body about to move**
 (c) Body moving with uniform speed (d) Body moving with uniform acceleration
17. At the point impending motion, the static frictional force is _____.
 (a) Zero (b) **Maximum** (c) Minimum (d) Infinite
18. At the point impending motion _____.
 (a) The body is on the verge of moving
 (b) The frictional force reaches the maximum value
 (c) The frictional force is equal to the tangential applied force
 (d) **All of the above**
19. Force is required to start motion is _____.
 (a) Less than that required for keeping it in motion
 (b) **More than that required for keeping it in motion**
 (c) Same as the force required for keeping it in motion
 (d) Zero, while force required for keeping it in motion is non- zero
20. The tangent of angle of friction is _____.
 (a) Angle of repose (b) **Co-efficient of friction**
 (c) Cone of friction (d) Limiting friction
21. The angle made by the resultant of normal reaction and frictional force with the normal reaction at the point of impending motion is called _____.
 (a) Angle of inclination (b) Angle of repose
 (c) **Angle of friction** (d) Normal angle

362 OBJECTIVE TYPE QUESTIONS

22. The unit of co-efficient of friction is _____.
- (a) Newton (b) Radian (c) Meter (d) **Dimensionless**
23. The frictional force is independent of
- (a) **The area of contact** (b) The coefficient of friction
(c) The normal reaction (d) The angle of friction
24. Once a body just begins to slide, it continues to slide because
- (a) **The body has inertia** (b) Inertia force acts on the body
(c) The body accelerates (d) The frictional force becomes less
25. The coefficient of friction between two surfaces is the constant of proportional between the applied tangential force and the normal reaction _____.
- (a) At the instant of application of the force
(b) At any instant when the body is at rest the force
(c) **At the instant of impending motion**
(d) At an instant after the motion takes place
26. The angle of friction is angle between
- (a) The incline and the horizontal
(b) The normal reaction and frictional force
(c) The weight of the body and the friction force
(d) **The normal reaction and the resultant**
27. Force acting in the opposite direction to the motion of the body is called force of friction.
- (a) **Agree** (b) Disagree
28. The friction experienced by a body, when at rest, is known as
- (a) **Static friction** (b) Dynamic friction
(c) Limiting friction (d) Coefficient of friction
29. The ratio of static friction to dynamic friction is always
- (a) Equal to one (b) Less than one
(c) **Greater than one** (d) None of these
30. The friction experienced by a body, when in motion, is known as
- (a) Rolling friction (b) **Dynamic friction**
(c) Limiting friction (d) Static friction
31. The static friction
- (a) Bears a constant ratio to the normal reaction between the two surfaces
(b) Is independent of the area of contact between the two surfaces
(c) Always acts in a direction, opposite to that in which the body tends to move
(d) **All of the above**
32. Static friction is always _____ dynamic friction.
- (a) Equal to (b) Less than (c) **Greater than**
33. The angle which the normal reaction makes with the resultant reaction is called angle of friction.
- (a) **Agree** (b) Disagree

34. The angle of inclination of the plane at which the body begins to move down the plane, is called
 (a) **Angle of friction** (b) Angle of repose
 (c) Angle of projection (d) None of these
35. The minimum force required to slide a body of weight W on a rough horizontal plane is
 (a) $W \sin \theta$ (b) $W \cos \theta$ (c) **$W \tan \theta$** (d) None of these
36. A body will begin to move down an inclined plane, if the angle of inclination of the plane is _____ the angle of friction.
 (a) Equal to (b) Less than (c) **Greater than**
37. Coefficient of friction is the ratio of the limiting friction to the normal reaction between the two bodies.
 (a) **Yes** (b) No
38. The force required to move the body up the plane will be minimum if it makes an angle with the inclined plane _____ the angle of friction.
 (a) **Equal to** (b) Less than (c) Greater than
39. A ladder is resting on a smooth ground and leaning against a rough vertical wall. The force of friction will act
 (a) Towards the wall at its upper end (b) Away from the wall at its upper end
 (c) Downward at its upper end (d) **Upward at its upper end**
40. A ladder is resting on a rough ground and leaning against a smooth vertical wall. The force of friction will act
 (a) Downward at its upper end (b) Upward at its upper end
 (c) **Zero at its upper end** (d) Perpendicular to the wall at its upper end
41. The angle of the inclined plane at which the body begins to slide down the plane, is called helix angle
 (a) True (b) **False**
42. Coefficient of friction depends upon
 (a) Area of contact only (b) **Nature of surface only**
 (c) Both (a) and (b) (d) None of these
43. Total reaction is
 (a) The resultant of limiting friction and sliding friction
 (b) The resultant of sliding friction **and** normal reaction
 (c) **The resultant of limiting friction and normal reaction**
 (d) There is no term called total reaction
44. Limiting friction depends upon
 (a) Materials of the bodies in contact
 (b) Weight of the body to be moved
 (c) Roughness of the surface of contact of the two bodies
 (d) **All of the above**

364 OBJECTIVE TYPE QUESTIONS

45. When a body resting on an inclined plane slides down the inclined plane under the action of its own weight, the angle of inclination of the inclined plane is
- (a) **Greater than the angle of repose** (b) Less than the angle of repose
 (c) Equal to angle of repose (d) None of these

Chapter 9: CENTROID OF PLANE FIGURES

1. Moment of total area about its centroidal axis is _____.
 (a) Twice the area (b) Three times the area
 (c) **Zero** (d) None of these
2. The centroid of a semicircle of radius R about its centroidal axis parallel to its diametric axis is _____.
 (a) $\frac{3R}{4\pi}$ (b) $\frac{3R}{8\pi}$ (c) $\frac{4R}{\pi}$ (d) $\frac{4R}{3\pi}$
3. An axis over which one half of the plane figure is just mirror image of the other half is _____.
 (a) Bottom most axis of the figure (b) **Axis of symmetry**
 (c) Unsymmetrical axis (d) None of these
4. Centroid of a triangle with base b and depth d is _____.
 (a) $\frac{b}{3}$ and $\frac{d}{3}$ (b) $\frac{b}{2}$ and $\frac{d}{2}$ (c) $\frac{b}{4}$ and $\frac{d}{4}$ (d) None of these
5. Centroid of a plane is the point at which _____.
 (a) Volume of body is concentrated
 (b) **Surface area assumed to be concentrated**
 (c) Weight of the body is assumed to be concentrated
 (d) All of the above
6. Centroid of trapezium of height h and parallel sides a and b measured from the base b is at a distance of _____.
 (a) $\frac{h}{2} \left(\frac{b+2a}{a+b} \right)$ (b) $\frac{h}{2} \left(\frac{b-2a}{a+b} \right)$ (c) $\frac{h}{3} \left(\frac{b+2a}{a+b} \right)$ (d) $\frac{h}{3} \left(\frac{b-2a}{a+b} \right)$
7. Centroid of quarter of circular lamina lies from diameter line at a distance of _____.
 (a) $\frac{2R}{3\pi}$ (b) $\frac{3R}{3\pi}$ (c) $\frac{4R}{3\pi}$ (d) $\frac{5R}{3\pi}$
8. The centroid of a triangular lamina of height h is situated at a distance _____ from its apex.
 (a) $\frac{h}{3}$ (b) $\frac{2h}{3}$ (c) $\frac{h}{2}$ (d) $\frac{h}{4}$
9. The centroid of a triangle of height h is located at a distance _____ from its base.
 (a) $\frac{h}{2}$ (b) $\frac{2h}{3}$ (c) $\frac{h}{3}$ (d) h

10. If the given plane figure is symmetrical about vertical Y-Y axis, the centroid lies on _____.
- (a) X-axis (b) **Y-Y axis** (c) Bottom (d) Top
11. Centroid of a sector of a circle at a distance of _____.
- (a) $\frac{4r}{3\pi}$ (b) $\frac{2r \sin \alpha}{3\alpha}$ (c) $\frac{r \sin \alpha}{2\alpha}$ (d) None of these
12. The C.G. of an equilateral triangle with each side a is _____ from any of the three sides.
- (a) $\frac{a\sqrt{3}}{2}$ (b) $\frac{a\sqrt{2}}{3}$ (c) $\frac{a}{2\sqrt{3}}$ (d) $\frac{a}{3\sqrt{2}}$
13. The centre of gravity of a semicircle lies at a distance of _____ from its base measured along the vertical radius.
- (a) $\frac{3r}{4\pi}$ (b) $\frac{4r}{3\pi}$ (c) $\frac{4\pi}{3r}$ (d) $\frac{3\pi}{4r}$
14. The x or y co-ordinate of the centroid of a quadrant of a circular area of radius r is _____.
- (a) $\frac{4r}{3\pi}$ (b) $\frac{2r}{3\pi}$ (c) $\frac{2r}{\pi}$ (d) $\frac{r}{\pi}$
15. The first moment of an area about the X-axis is _____.
- (a) $\int x dA$ (b) $\int y dA$ (c) $\int x^2 dA$ (d) $\int y^2 dA$
16. The centroid of lamina _____.
- (a) Must be a point on the lamina
 (b) Is a point which can be made to lie on or outside the lamina by changing the co-ordinates system
 (c) Is a fixed point in space regardless of the orientation of the lamina
 (d) **Is a unique point fixed with respect to the lamina**
17. Centroid conveys some clue about _____.
- (a) The orientation of a surface (b) Centre of a body
 (c) Shape and disposition of the area (d) **Area of cross section**
18. The centroid of a plane lamina will not be at its geometrical centre if it is a _____.
- (a) Rectangle (b) Circle
 (c) **Right angled triangle** (d) Square
19. The point, through which the whole weight of the body acts, irrespective of its position, is known as
- (a) Moment of inertia (b) **Centre of gravity**
 (c) Centre of percussion (d) Centre of mass
20. The term centroid is
- (a) **The same as centre of gravity** (b) The point of suspension
 (c) The point of application of the resultant of all the forces tending to cause a body to rotate about a certain axis
 (d) None of the above

366 OBJECTIVE TYPE QUESTIONS

21. An irregular body may have more than one centre of gravity.
 (a) **Yes** (b) No
22. The centre of gravity of a rectangle lies at a point where its two diagonals meet each other.
 (a) **Agree** (b) Disagree
23. The centre of gravity of a semicircle lies at a distance of _____ from its base, measured along the vertical radius.
 (a) $\frac{3r}{8}$ (b) $\frac{4r}{3\pi}$ (c) $\frac{8r}{3}$ (d) $\frac{3r}{4\pi}$
24. The centre of gravity of a right circular solid cone is at a distance of _____ from its base, measured along the vertical axis.
 (a) $\frac{h}{2}$ (b) $\frac{h}{3}$ (c) $\frac{h}{4}$ (d) $\frac{h}{6}$
 where h = Height of a right circular solid cone.
25. The centre of gravity of a right-angled triangle lies at its geometrical centre.
 (a) Correct (b) **Incorrect**
26. The centre of gravity of a quadrant of a circle lies along its central radius (r) at a distance of
 (a) $0.5r$ (b) **$0.6r$** (c) $0.7r$ (d) $0.8r$
27. The centre of gravity of a T-section $100 \text{ mm} \times 150 \text{ mm} \times 50 \text{ mm}$ from its bottom is
 (a) 50 mm (b) 75 mm (c) **87.5 mm** (d) 125 mm
28. Centre of gravity of a triangle lies at a point where its medians intersect each other
 (a) **True** (b) False
29. The centre of gravity of hemisphere lies at a distance of $\frac{3r}{8}$ from its base measured along the vertical radius
 (a) **True** (b) False

Chapter 10: MOMENT OF INERTIA

1. The unit of radius of gyration is _____.
 (a) **mm** (b) mm^2 (c) mm^3 (d) mm^4
2. The moment of inertia of an area about an axis which is in a plane perpendicular to the area is called _____.
 (a) Radius of gyration (b) **Polar moment of inertia**
 (c) Second moment of area (d) None of these
3. The moment of inertia of circle with D as its diameter about its centroidal axis is _____.
 (a) $\frac{\pi D^2}{32}$ (b) $\frac{\pi D^2}{64}$ (c) $\frac{\pi D^4}{32}$ (d) $\frac{\pi D^4}{64}$

4. The moment of inertia of a square of side b about an axis through its centroid is _____.
- (a) $\frac{b^4}{12}$ (b) $\frac{b^4}{8}$ (c) $\frac{b^4}{36}$ (d) $\frac{b^3}{12}$
5. Moment of inertia is a _____.
- (a) First moment of area (b) **Second moment of area**
(c) Third moment of area (d) None of these
6. M.I. of circular section about centroidal axis is _____.
- (a) $\frac{\pi D^4}{48}$ (b) $\frac{\pi D^4}{32}$ (c) $\frac{\pi D^4}{64}$ (d) $\frac{\pi D^4}{128}$
7. M.I. of triangular section about base having base b and height h is _____.
- (a) $\frac{bh^3}{36}$ (b) $\frac{bh^3}{12}$ (c) $\frac{bh^3}{64}$ (d) None of these
8. The unit of moment of inertia of an area is _____.
- (a) m^3 (b) m^2 (c) **m^4** (d) N/m^2
9. The polar moment of inertia of circular section of diameter ' D ' about its centroidal axis is _____.
- (a) $\frac{\pi D^4}{64}$ (b) $\frac{\pi D^4}{32}$ (c) $\frac{\pi D^2}{32}$ (d) $\frac{\pi D^4}{16}$
10. M.I. of hollow circular section whose external diameter is 8 mm and internal diameter 4 mm about centroidal axis is _____.
- (a) 435.7 mm⁴ (b) 337.5 mm⁴ (c) 237.5 mm⁴ (d) **188.4 mm⁴**
11. The value of moment of inertia depends on
- (a) Type of materials (b) Weight of materials
(c) Density of materials (d) **Cross-sectional dimensions**
12. Moment of inertia is a
- (a) First order term (b) **Second order term**
(c) Fourth order term (d) Third order term
13. The moment of inertia of a rectangular lamina of sides b and h about its neutral axis parallel to the sides b is given by _____.
- (a) $\frac{bh^3}{12}$ (b) $\frac{bh^3}{36}$ (c) $\frac{hb^3}{12}$ (d) $\frac{hb^3}{3}$
14. Mass moment of inertia of a thin rod about its one end is _____ the mass moment of inertia of the same rod about its mid-point.
- (a) Same as (b) Twice (c) Thrice (d) **Four times**
15. Moment of inertia of a circular section about an axis perpendicular to the section is
- (a) $\frac{\pi d^3}{16}$ (b) $\frac{\pi d^3}{32}$ (c) $\frac{\pi d^4}{32}$ (d) $\frac{\pi d^4}{64}$

368 OBJECTIVE TYPE QUESTIONS

16. Moment of inertia of a triangular section of base b and height h about an axis passing through its C.G. and parallel to the base b , is
- (a) $\frac{bh^3}{4}$ (b) $\frac{bh^3}{8}$ (c) $\frac{bh^3}{12}$ (d) $\frac{bh^3}{36}$
17. Moment of inertia of a triangular section of base b and height h about an axis through its base b , is
- (a) $\frac{bh^3}{4}$ (b) $\frac{bh^3}{8}$ (c) $\frac{bh^3}{12}$ (d) $\frac{bh^3}{36}$
18. Moment of inertia of a rectangular section having width b and depth d about an axis passing through its C.G. and parallel to the depth d , is
- (a) $\frac{db^3}{12}$ (b) $\frac{bd^3}{12}$ (c) $\frac{db^3}{36}$ (d) $\frac{bd^3}{36}$
19. Moment of inertia of a triangular section of base b and height h about an axis passing through the vertex and parallel to the base, is _____ than that passing through its C.G. and parallel to the base
- (a) **Nine times** (b) Six times (c) Four times (d) Two times
20. Moment of inertia of a thin disc of mass m and radius r , about an axis through its centre of gravity and perpendicular to the plane of the disc
- (a) $\frac{mr^2}{2}$ (b) $\frac{mr^2}{4}$ (c) $\frac{mr^2}{6}$ (d) $\frac{mr^2}{8}$
21. Moment of inertia of a thin rod of mass m and length l , about an axis through its centre of gravity and perpendicular to its length is
- (a) $\frac{ml^2}{4}$ (b) $\frac{ml^2}{6}$ (c) $\frac{ml^2}{8}$ (d) $\frac{ml^2}{12}$
22. Moment of inertia of a solid cylinder of mass m , radius r and length l , about the longitudinal axis or polar axis is
- (a) $\frac{mr^2}{2}$ (b) $\frac{mr^2}{4}$ (c) $\frac{mr^2}{6}$ (d) $\frac{mr^2}{8}$
23. Moment of inertia of a thin spherical shell of mass m and radius r , about its diameter is
- (a) $\frac{mr^2}{3}$ (b) $\frac{2mr^2}{3}$ (c) $\frac{2mr^2}{5}$ (d) $\frac{3mr^2}{5}$
24. Moment of inertia of a sphere of mass m and radius r , about an axis tangential to it, is
- (a) $\frac{2mr^2}{3}$ (b) $\frac{2mr^2}{5}$ (c) $\frac{7mr^2}{3}$ (d) $\frac{7mr^2}{5}$
25. Moment of inertia of a solid sphere of mass m and radius r , about is
- (a) $\frac{2mr^2}{3}$ (b) $\frac{2mr^2}{5}$ (c) mr^2 (d) $\frac{mr^2}{2}$

ANSWERS TO OBJECTIVE TYPE QUESTIONS

Chapter 1

- | | | | | | |
|---------|---------|---------|---------|---------|---------|
| 1. (b) | 2. (c) | 3. (c) | 4. (d) | 5. (d) | 6. (a) |
| 7. (b) | 8. (d) | 9. (c) | 10. (b) | 11. (a) | 12. (c) |
| 13. (a) | 14. (c) | 15. (a) | 16. (b) | 17. (d) | 18. (d) |
| 19. (c) | 20. (a) | 21. (d) | 22. (b) | 23. (b) | 24. (a) |

Chapter 2

- | | | | | | |
|---------|---------|---------|---------|---------|---------|
| 1. (a) | 2. (a) | 3. (c) | 4. (a) | 5. (d) | 6. (b) |
| 7. (c) | 8. (c) | 9. (c) | 10. (c) | 11. (b) | 12. (a) |
| 13. (d) | 14. (a) | 15. (d) | 16. (a) | 17. (d) | 18. (a) |
| 19. (d) | 20. (c) | 21. (c) | 22. (b) | 23. (d) | 24. (b) |
| 25. (a) | 26. (b) | 27. (d) | 28. (d) | 29. (b) | 30. (a) |
| 31. (d) | 32. (a) | 33. (c) | 34. (c) | 35. (c) | 36. (a) |
| 37. (c) | 38. (b) | | | | |

Chapter 3 and 4

- | | | | | | |
|---------|---------|---------|---------|---------|---------|
| 1. (c) | 2. (d) | 3. (a) | 4. (c) | 5. (d) | 6. (b) |
| 7. (c) | 8. (d) | 9. (d) | 10. (b) | 11. (b) | 12. (b) |
| 13. (c) | 14. (b) | 15. (a) | 16. (c) | 17. (c) | 18. (a) |
| 19. (b) | 20. (a) | 21. (a) | 22. (b) | 23. (c) | 24. (b) |
| 25. (a) | 26. (d) | 27. (d) | 28. (b) | 29. (b) | 30. (a) |
| 31. (b) | 32. (d) | 33. (b) | 34. (a) | 35. (a) | 36. (b) |
| 37. (a) | 38. (d) | 39. (c) | 40. (c) | 41. (d) | 42. (c) |
| 43. (a) | | | | | |

Chapter 5

- | | | | | | |
|---------|---------|---------|---------|---------|---------|
| 1. (a) | 2. (c) | 3. (c) | 4. (b) | 5. (c) | 6. (a) |
| 7. (c) | 8. (c) | 9. (a) | 10. (b) | 11. (c) | 12. (d) |
| 13. (a) | 14. (b) | 15. (c) | 16. (b) | 17. (c) | 18. (a) |
| 19. (a) | 20. (b) | 21. (b) | 22. (a) | 23. (b) | 24. (d) |
| 25. (a) | 26. (b) | 27. (a) | | | |

370 OBJECTIVE TYPE QUESTIONS

Chapter 6

- | | | | | | |
|---------|---------|---------|---------|---------|---------|
| 1. (a) | 2. (b) | 3. (b) | 4. (b) | 5. (c) | 6. (a) |
| 7. (b) | 8. (c) | 9. (b) | 10. (c) | 11. (c) | 12. (c) |
| 13. (d) | 14. (d) | 15. (b) | 16. (a) | 17. (b) | 18. (d) |
| 19. (b) | | | | | |

Chapter 7

- | | | | | | |
|--------|--------|--------|---------|--------|--------|
| 1. (c) | 2. (c) | 3. (b) | 4. (d) | 5. (b) | 6. (a) |
| 7. (a) | 8. (c) | 9. (c) | 10. (b) | | |

Chapter 8

- | | | | | | |
|---------|---------|---------|---------|---------|---------|
| 1. (d) | 2. (c) | 3. (c) | 4. (b) | 5. (c) | 6. (a) |
| 7. (c) | 8. (b) | 9. (b) | 10. (a) | 11. (b) | 12. (a) |
| 13. (d) | 14. (a) | 15. (c) | 16. (b) | 17. (b) | 18. (d) |
| 19. (b) | 20. (b) | 21. (c) | 22. (d) | 23. (a) | 24. (a) |
| 25. (c) | 26. (d) | 27. (a) | 28. (a) | 29. (c) | 30. (b) |
| 31. (d) | 32. (c) | 33. (a) | 34. (a) | 35. (c) | 36. (c) |
| 37. (a) | 38. (a) | 39. (d) | 40. (c) | 41. (b) | 42. (b) |
| 43. (c) | 44. (d) | 45. (a) | | | |

Chapter 9

- | | | | | | |
|---------|---------|---------|---------|---------|---------|
| 1. (c) | 2. (d) | 3. (b) | 4. (a) | 5. (b) | 6. (c) |
| 7. (c) | 8. (b) | 9. (c) | 10. (b) | 11. (b) | 12. (c) |
| 13. (b) | 14. (a) | 15. (b) | 16. (d) | 17. (d) | 18. (c) |
| 19. (b) | 20. (a) | 21. (a) | 22. (a) | 23. (b) | 24. (c) |
| 25. (b) | 26. (b) | 27. (c) | 28. (a) | 29. (a) | |

Chapter 10

- | | | | | | |
|---------|---------|---------|---------|---------|---------|
| 1. (a) | 2. (b) | 3. (d) | 4. (a) | 5. (b) | 6. (c) |
| 7. (b) | 8. (c) | 9. (b) | 10. (d) | 11. (d) | 12. (b) |
| 13. (a) | 14. (d) | 15. (c) | 16. (d) | 17. (c) | 18. (a) |
| 19. (a) | 20. (a) | 21. (d) | 22. (a) | 23. (b) | 24. (d) |
| 25. (b) | | | | | |

EXAMINATION PAPERS OF VTU

First and Second Semester B.E. Degree Examination, Dec. 2013/Jan. 2014

ELEMENTS OF CIVIL ENGINEERING AND ENGINEERING MECHANICS

Time: 3 hrs.

Max. Marks: 100

- Note:**
1. Answer any FIVE full questions, choosing at least two from each part.
 2. Answer all objective type questions only in OMR sheet page 5 of the answer booklet.
 3. Answer to objective type questions on sheets other than OMR will not be valued.

PART-A

1. (a) Choose the correct answers for the following: **(04 Marks)**
- (i) A bridge constructed at some angle to river flow is
(A) skew bridge (B) square bridge
(C) steel bridge (D) lift bridge
 - (ii) The structure that separates roads into separate lanes is called
(A) Kerb (B) median
(C) road margin (D) camber
 - (iii) The upstream side of a dam
(A) arch dams (B) gravity dam (C) earth dam (D) reservoir
 - (iv) Geotechnical engineering involves the study of
(A) water (B) soil
(C) air (D) none of these
- (b) With the help of neat sketches, briefly explain the cross-section of road and gravity dam. **(10 Marks)**
- (c) What are infrastructure related projects? **(06 Marks)**
2. (a) Choose the correct answers for the following: **(04 Marks)**
- (i) The component of a force perpendicular to its line of action is
(A) maximum (B) minimum (C) zero (D) none of these

372 EXAMINATION PAPERS OF VTU

- (ii) The moment of a force about a moment centre lying on its line of action is
(A) maximum (B) minimum (C) zero (D) none of these
 - (iii) Two equal and opposite forces separated by a distance will produce
(A) translation (B) rotation
(C) both translation and rotation (D) none of these
 - (iv) Moment of a force will produce
(A) translation (B) rotation
(C) both translation and rotation (D) none of these
- (b) A block weighing $W = 10 \text{ kN}$ is resting on an inclined plane as shown in Figure Q2(b). Determine its components normal to and parallel to the inclined plane. The plane makes an angle of 20° with the horizontal. **(04 Marks)**

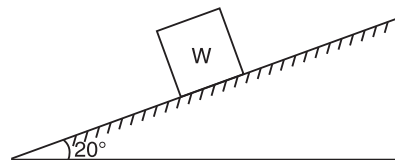

Figure Q2(b)

- (c) A body is subjected to the three forces as shown in Figure Q2(c). If possible determine the direction of the force "F" so that the resultant is in 'x' direction, when (i) $F = 5000 \text{ N}$, (ii) $F = 3000 \text{ N}$. **(12 Marks)**

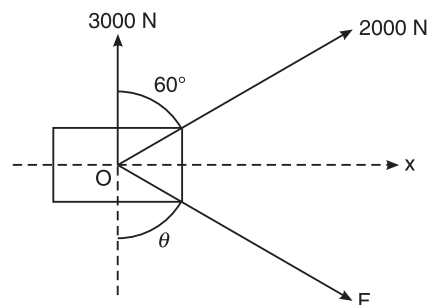

Figure Q2(c)

3. (a) Choose the correct answers for the following: **(04 Marks)**
- (i) In case of coplanar concurrent force the resultant force passes through
(A) point of concurrence (B) away from point of concurrence
(C) different plane (D) none of these
 - (ii) If two concurrent forces each of 'P' act at right angles to each other, their resultant is
(A) $2P$ (B) P
(C) $\sqrt{2}P$ (D) $2\sqrt{P}$

- (iii) If $\Sigma V = 0$ and $\Sigma H = 0$ for a coplanar nonconcurrent force system, then it is in
(A) equilibrium (B) translation (C) rotation (D) none of these
- (iv) Conditions of equilibrium for a coplanar concurrent force system is
(A) one (B) two (C) three (D) four
- (b) Two forces acting on a body are 500 N and 1000 N as shown in Figure Q3(b). Determine the third force "F" such that the resultant of all the three forces is 1000 N directed at 45° to 'x' axis. **(06 Marks)**

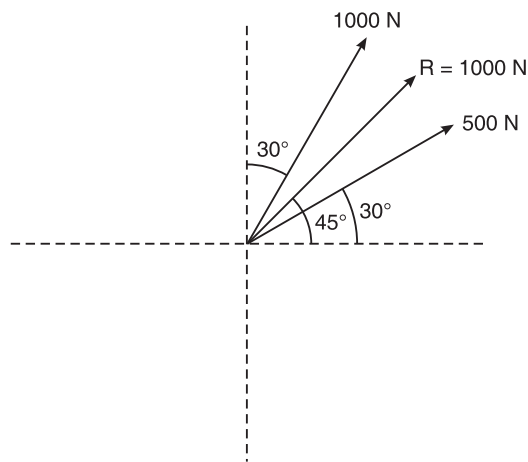

Figure Q3(b)

- (c) Determine the resultant of the four forces acting on a body as shown in Figure Q3(c) with respect to point "O". **(10 Marks)**

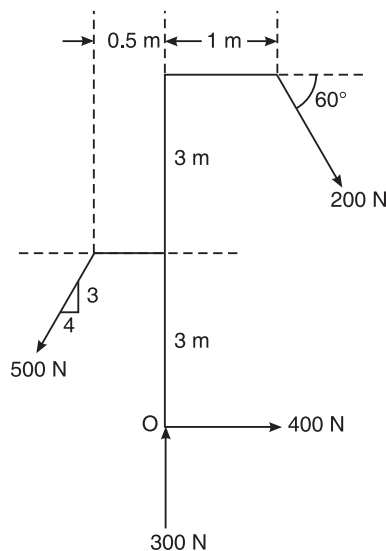

Figure Q3(c)

374 EXAMINATION PAPERS OF VTU

4. (a) Choose the correct answers for the following: **(04 Marks)**
- (i) The centroid of a triangle of height 'h' is located at a _____ distance from its apex.
(A) $h/2$ (B) $2h/3$ (C) $h/3$ (D) h
 - (ii) Intersection of _____ number of symmetrical axes will give centroid of plane area.
(A) 3 (B) 4 (C) 2 (D) none of these
 - (iii) Moment of an area about a reference axis passing through its centroid is
(A) maximum (B) minimum
(C) zero (D) none of these
 - (iv) Centroid of a semicircle from an axis passing through the diameter is
(A) $4r/3\pi$ (B) $3r/4\pi$
(C) $3\pi/4r$ (D) $4\pi/3r$
- (b) Determine the centroid of a semi-circular lamina of radius "r" by the method of integration. **(06 Marks)**
- (c) Determine the centroid of the shaded area shown in Figure Q4(c) with respect to OX and OY. **(10 Marks)**

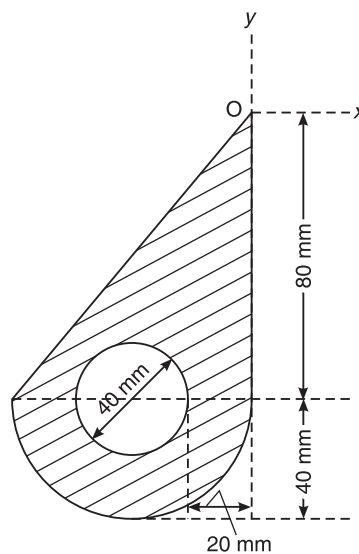

Figure Q4(c)

PART-B

5. (a) Choose the correct answers for the following: **(04 Marks)**
- (i) If three forces are acting at a point and are in equilibrium, out of which two are acting in the same line, then the third force is
(A) maximum (B) minimum
(C) zero (D) none of these

- (ii) A rigid body is inequilibrium if the resultant force of concurrent for system is
 (A) positive (B) negative
 (C) zero (D) none of these
- (iii) Lami's theorem is valid for _____ number of concurrent forces in equilibrium
 (A) two (B) three
 (C) four (D) none of these
- (iv) The force equal and opposite to resultant is called as
 (A) equilibrant (B) similar force
 (C) opponent force (D) none of these
- (b) State and prove Lami's theorem. **(06 Marks)**
- (c) The frictionless pulley 'A' shown in Figure Q5(c) is supplied by two bars AB and AC which are hinged at 'B' and 'C' to a vertical wall. The flexible cable DG hinged at 'D', goes over the pulley and supports a load of 20 kN at 'G'. The angles between the various members are shown in the figure. Determine the forces in the bars AB and AC. Neglect the size and weight of the pulley. **(10 Marks)**

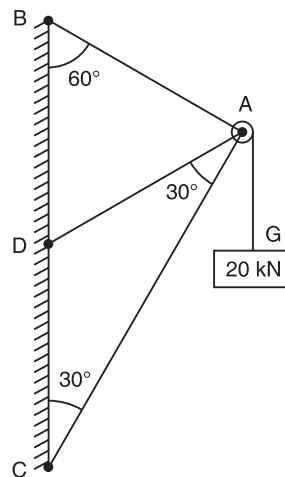

Figure Q5(c)

6. (a) Choose the correct answers for the following: **(04 Marks)**
- (i) A hinged support can have _____ reactions.
 (A) 2 (B) 4 (C) 1 (D) none of these
- (ii) A determinate beam can have _____ number of unknowns.
 (A) 2 (B) 3 (C) 1 (D) 4
- (iii) A fixed support can have _____ reactions.
 (A) 1 (B) 2 (C) 3 (D) 4
- (iv) UDL stands for
 (A) Uniformly distributed load (B) Uniform dead load
 (C) Uniform door load (D) Uniform diameter load

376 EXAMINATION PAPERS OF VTU

- (b) The cantilever beam shown in Figure Q6(b) is fixed at 'A' and is free at 'B'. Determine the reaction when it is loaded as shown. **(06 Marks)**

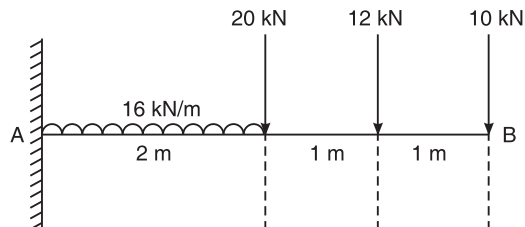

Figure Q6(b)

- (c) Find the forces in all the members of the truss loaded as shown in Figure 6(c). Tabulate the results. **(10 Marks)**

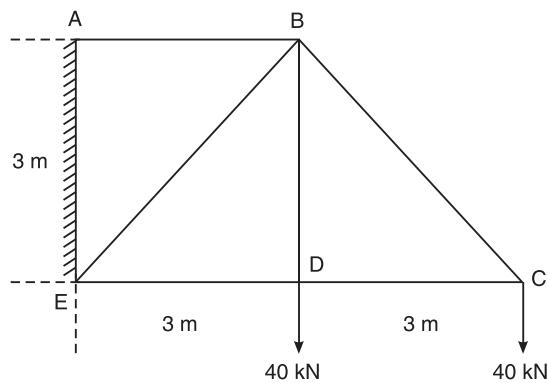

Figure Q6(c)

7. (a) Choose the correct answers for the following: **(04 Marks)**
- (i) Compared to static friction, kinetic friction is
(A) greater (B) smaller
(C) very large (D) zero
 - (ii) Friction force is _____ to the contact surface between bodies.
(A) parallel (B) perpendicular
(C) tangential (D) none of these
 - (iii) Friction force is a _____ force.
(A) active (B) passive (C) normal (D) none of these
 - (iv) The tangent of the angle of friction is _____.
(A) angle of repose (B) coefficient of friction
(C) cone of friction (D) limiting friction
- (b) Define: (i) Angle of friction; (ii) Coefficient of friction; (iii) Cone of friction. **(06 Marks)**

- (c) What is the value of 'P' in the system shown in Figure Q7(c), to cause the motion to impend to the right? Assume the pulley is smooth and coefficient of friction between the other contact surfaces is 0.20. **(10 Marks)**

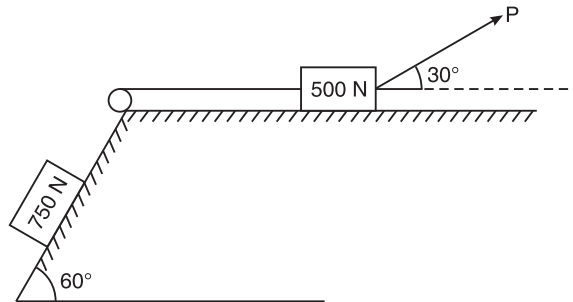

Figure Q7(c)

8. (a) Choose the correct answers for the following: **(04 Marks)**

- (i) Unit of second moment of area is
(A) m (B) m^2 (C) m^4 (D) m^5
- (ii) Unit of radius of gyration is _____.
(A) m (B) m^2 (C) m^3 (D) m^4
- (iii) Moment of inertia of a square of side 'b' about an axis through its centroid is
(A) $b^4/12$ (B) $b^4/8$ (C) $b^4/36$ (D) $b^3/12$
- (iv) P_{dar} moment of inertia is
(A) $I_{xx} + I_{yy}$ (B) $I_{xx} + I_{zz}$
(C) $I_{yy} + I_{zz}$ (D) none of these

- (b) Define: (i) Moment of inertia; (ii) Radius of gyration; (iii) Polar moment of inertia.

(06 Marks)

- (c) Determine the moment of inertia of the symmetrical I-section shown in Figure Q8(c) about its centroidal X-X and Y-Y axis. **(10 Marks)**

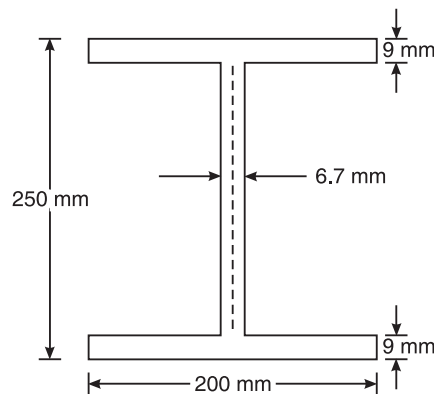

Figure Q8(c)

378 EXAMINATION PAPERS OF VTU

First and Second Semester B.E. Degree Examination, June/July 2013

**ELEMENTS OF CIVIL ENGINEERING AND
ENGINEERING MECHANICS**

Time: 3 hrs.

Max. Marks: 100

- Note:**
1. Answer any FIVE full questions, choosing at least two from each part.
 2. Answer all objective type questions only on OMR sheet page 5 of the answer booklet.
 3. Answer to objective type questions on sheets other than OMR will not be valued.
 4. Assume missing data suitably.

PART-A

1. (a) Choose the correct answers for the following: **(04 Marks)**
 - (i) Geotechnical engineering involves the study of
(A) Water (B) Soil (C) Air (D) All of these
 - (ii) By-pass road is constructed
(A) Inside the city (B) Over the main road
(C) Around the city (D) None of these
 - (iii) The part of civil engineering which deals with waste water and solid waste is called
(A) Water supply engineering (B) Geotechnical engineering
(C) Sanitary engineering (D) Structural engineering
 - (iv) A bascule bridge is a
(A) Floating bridge (B) Arch bridge
(C) Suspension bridge (D) Movable bridge
- (b) Write a note on role of civil engineer in infrastructural development. **(10 Marks)**
- (c) Name the different types of roads as per Nagpur plan. **(06 Marks)**
2. (a) Choose the correct answers for the following: **(04 Marks)**
 - (i) Moment of a force can be defined as the product of force and _____ distance from the line of action of force to the moment center.
(A) Least (B) Maximum
(C) Any (D) None of these
 - (ii) Effect of force on a body depends on
(A) Direction (B) Magnitude
(C) Position (D) All of these
 - (iii) The forces which meet at one point have their line of action in different plane are called
(A) Coplanar concurrent forces
(B) Non coplanar concurrent forces
(C) Non coplanar non concurrent forces
(D) None of these

- (iv) Couple means two forces acting parallel
 (A) Equal in magnitude and in the same direction
 (B) Not equal in magnitude but in the same direction
 (C) Equal in magnitude but opposite in direction
 (D) None of these
- (b) Define force and state its characteristics. **(06 Marks)**
- (c) Determine the magnitude and direction of the resultant for the system of forces shown in Figure Q2(c). Use classical method. **(10 Marks)**

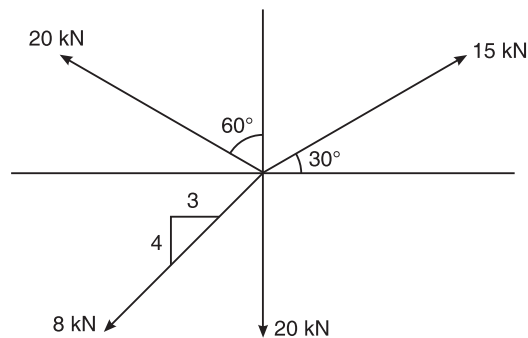

Figure Q2(c)

3. (a) Choose the correct answer for the following: **(04 Marks)**
- (i) The technology of finding the resultant of a system of forces is called
 (A) Resultant (B) Resolution
 (C) Composition (D) None of these
- (ii) Equilibrant is nothing but a resultant
 (A) Equal in magnitude and in the same direction
 (B) Equal in magnitude but opposite in direction
 (C) Not equal in magnitude but in the same direction
 (D) Not equal in magnitude and opposite in direction
- (iii) If two forces P and Q ($P > Q$) act on the same straight line but in opposite direction their resultant is
 (A) $P + Q$ (B) P/Q
 (C) $Q - P$ (D) $P - Q$
- (iv) In coplanar concurrent force system if $\Sigma H = 0$, then the resultant is
 (A) Horizontal (B) Vertical
 (C) Moment (D) None of these
- (b) State and prove Varignon's theorem of the moments. **(06 Marks)**
- (c) Two spheres each of radius 100 mm and weight 5 kN is in a rectangular box as shown in Figure Q3(c). Calculate the reactions at the point of contacts. **(10 Marks)**

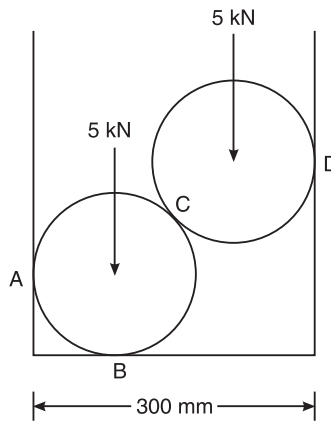

Figure Q3(c)

4. (a) Choose the correct answer for the following: (04 Marks)
- (i) Moment of total area about its centroidal axis is
 - (A) Twice the area
 - (B) Three times the area
 - (C) Zero
 - (D) None of these
 - (ii) The centroid of a semicircle of radius R about its centroidal axis parallel to its diametric axis is
 - (A) $3R/4\pi$
 - (B) $3R/8\pi$
 - (C) $4R/\pi$
 - (D) $4R/3\pi$
 - (iii) An axis over which one half of the plane figure is just mirror of the other half which is
 - (A) Bottom most axis of the figure
 - (B) Axis of symmetry
 - (C) Unsymmetrical axis
 - (D) None of these
 - (iv) Centroid of a rectangle of base width b and depth d is
 - (A) $b/3$ and $d/3$
 - (B) $b/2$ and $d/2$
 - (C) $b/4$ and $d/4$
 - (D) None of these
- (b) Determine the centroid of a triangle by the method of integration. (06 Marks)
- (c) Locate the centroid of the lamina shown in Figure Q4(c) with respect to point O. (10 Marks)

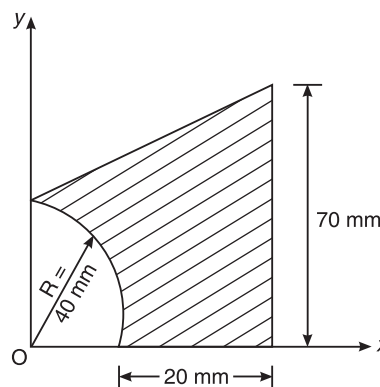

Figure Q4(c)

PART-B

5. (a) Choose the correct answers for the following: **(04 Marks)**

- (i) The necessary condition of equilibrium of a coplanar concurrent force system is algebraic sum of _____ must be zero.
 - (A) Horizontal and vertical forces
 - (B) Moment of forces
 - (C) Horizontal, vertical and moment of forces
 - (D) None of these
- (ii) In non concurrent force system if $\Sigma H = 0$, $\Sigma V = 0$, then the resultant is
 - (A) Horizontal
 - (B) Vertical
 - (C) Moment
 - (D) Zero
- (iii) The force which is equal and opposite to the resultant is
 - (A) Resultant force
 - (B) Force
 - (C) Equilibrant
 - (D) None of these
- (iv) The procedure of resolution is
 - (A) To find the resultant of the force system
 - (B) To break up an inclined force in to two components
 - (C) To find the equilibrant
 - (D) None of these

(b) Determine the reactions at the point of contact for the sphere shown in Figure Q5(b). **(06 Marks)**

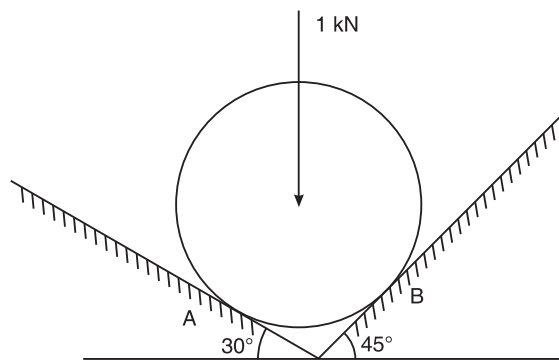

Figure Q5(b)

(c) Determine the angle θ for the system of strings ABCD in equilibrium as shown in Figure Q5(c). **(10 Marks)**

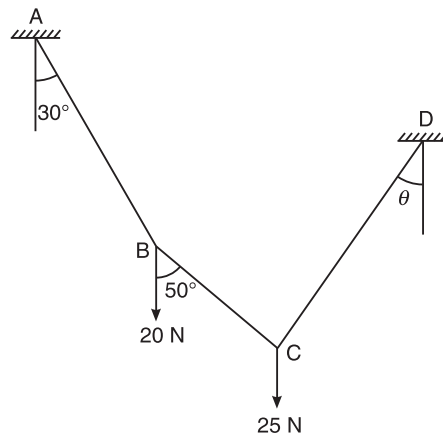

Figure Q5(c)

6. (a) Choose the correct answers for the following: **(04 Marks)**

- (i) Statically determinate beams are
 - (A) The beams which can be analyzed completely using static equations of equilibrium
 - (B) The beams which can be without using static equations of equilibrium
 - (C) Fixed beams
 - (D) None of these
- (ii) Fixed beams are
 - (A) One end is fixed and the other is simply supported
 - (B) Both ends are fixed
 - (C) Both ends are roller supported
 - (D) One end is fixed and the other is free
- (iii) The number of reaction components at fixed end of a beam are
 - (A) 2
 - (B) 3
 - (C) 4
 - (D) None of these
- (iv) U.D.L. stands for
 - (A) Uniform dead load
 - (B) Uniform distributed load
 - (C) Uniform door load
 - (D) All of these

(b) Explain different types of supports. **(06 Marks)**

(c) Determine the reactions at the support for the beam shown in Figure Q6(c). **(10 Marks)**

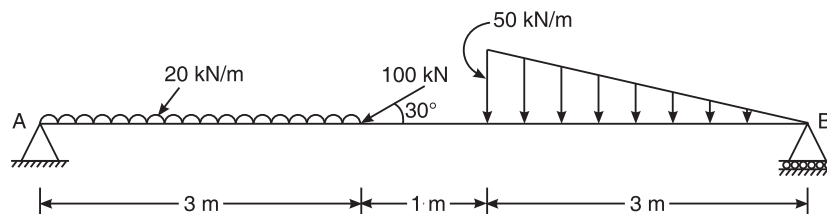

Figure Q6(c)

7. (a) Choose the correct answers for the following: **(04 Marks)**

- (i) Angle of friction is angle between
 - (A) the incline and horizontal
 - (B) the normal reaction and friction force
 - (C) the weight of the body and the friction force
 - (D) normal reaction and the resultant
- (ii) The force of friction developed at the contact surface is always
 - (A) Parallel to the plane and along the direction of the applied force
 - (B) Perpendicular to the plane
 - (C) Parallel to the plane and opposite to the direction of the motion
 - (D) All of these
- (iii) The maximum inclination of the plane on which the body free from external forces can repose is called
 - (A) Cone of friction
 - (B) Angle of friction
 - (C) Angle of repose
 - (D) None of these
- (iv) The force of friction depends on
 - (A) Area of contact
 - (B) Roughness of the surface
 - (C) Both area of contact and roughness of the surface
 - (D) None of these

(b) State the laws of static friction. **(04 Marks)**

(c) A uniform ladder of length 15 m and weight 750 N rests against a vertical wall making an angle of 60° with the horizontal. Co-efficient of friction between the wall and the ladder is 0.3 and between the ground and the ladder is 0.25. A man weighing 500 N ascends the ladder. How long will he be able to go before the ladder slips? **(12 Marks)**

8. (a) Choose the correct answers for the following: **(04 Marks)**

- (i) The unit of radius of Gyration is
 - (A) mm
 - (B) mm^2
 - (C) mm^3
 - (D) mm^4
- (ii) The moment of inertia of an area about an axis which is in a plane perpendicular to the area is called
 - (A) Radius of Gyration
 - (B) Polar moment of inertia
 - (C) Second moment of area
 - (D) None of these
- (iii) The moment of inertia of a circle with 'd' as its diameter about its centroidal axis
 - (A) $\pi D^2/32$
 - (B) $\pi D^2/64$
 - (C) $\pi D^4/32$
 - (D) $\pi D^4/64$
- (iv) The moment of inertia of a square of side 'b' about an axis through its centroid is
 - (A) $b^4/12$
 - (B) $b^4/8$
 - (C) $b^4/36$
 - (D) $b^3/12$

(b) State and prove parallel axis theorem. **(06 Marks)**

384 EXAMINATION PAPERS OF VTU

- (c) Find the moment of inertia of the region shown in Figure Q8(c) about horizontal axis AB and also find the radius of Gyration about the same axis. All dimensions are in mm.

(10 Marks)

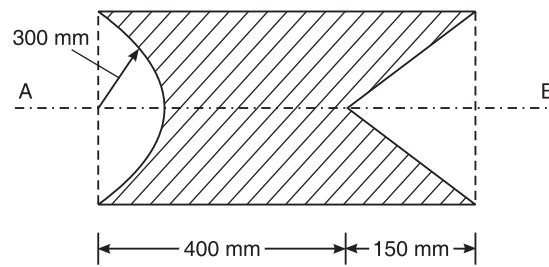

Figure Q8(c)

First and Second Semester B.E. Degree Examination, January 2013

**ELEMENTS OF CIVIL ENGINEERING AND
ENGINEERING MECHANICS**

Time: 3 hrs.

Max. Marks: 100

- Note:**
1. Answer any FIVE full questions, choosing at least two from each part.
 2. Answer all objective type questions only on OMR sheet page 5 of the answer booklet.
 3. Answer to objective type questions on sheets other than OMR will not be valued.

PART-A

1. (a) Choose the correct answers for the following: **(04 Marks)**
- (i) A branch of civil engineering that deals with testing soils and foundation design is called
(A) Geotechnical engineering (B) Structural engineering
(C) Environmental engineering (D) Highway engineering
 - (ii) Highways which are superior to National Highways and are provided wherever volume of traffic is very high are
(A) Airways (B) Expressways
(C) Roadways (D) District roads
 - (iii) Composite material made using cement concrete and steel is called
(A) Plain cement concrete (B) Composite cement concrete
(C) Reinforced cement concrete (D) Prestressed cement concrete
 - (iv) A bridge constructed at some angle to river flow is
(A) Bascule bridge (B) Square bridge
(C) RCC bridge (D) Skew bridge
- (b) Write a note on impact of infrastructural development on the economy of the country. **(08 Marks)**
- (c) Explain different types of dams, with neat sketches. **(08 Marks)**
2. (a) Choose the correct answers for the following: **(04 Marks)**
- (i) Forces whose line of action lie along the same line are
(A) Coplanar non-concurrent (B) Coplanar parallel
(C) Collinear (D) Concurrent
 - (ii) Moment of a force about a moment centre is the measure of its
(A) Rotational effect (B) Translatory effect
(C) Both A and B (D) None of these
 - (iii) The translatory effect of a couple on the rigid body is
(A) Zero (B) Maximum
(C) Minimum (D) None of these

386 EXAMINATION PAPERS OF VTU

- (iv) An object with only mass but no size in mechanics is
(A) Rigid body (B) Point body
(C) Particle (D) Deformable body
- (b) State and prove Varignon's theorem. **(08 Marks)**
- (c) (i) A force of 200 N is acting on a block shown in Figure Q2(c)(i). Find the components of forces along horizontal and vertical axes. Ignore the friction between contact surfaces.

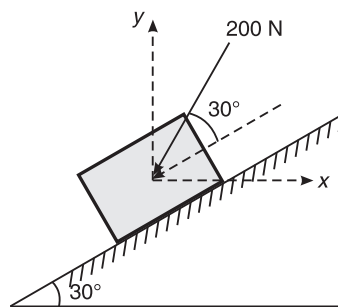

Figure Q2(c)(i)

- (ii) A nail is to be removed by applying 4 kN force and a force 'F' as shown in Figure Q2(c)(ii). Find the magnitude of force 'F' so that the nail is pulled out vertically from the ground. Also, determine the resulting pull along vertical axis. **(08 Marks)**

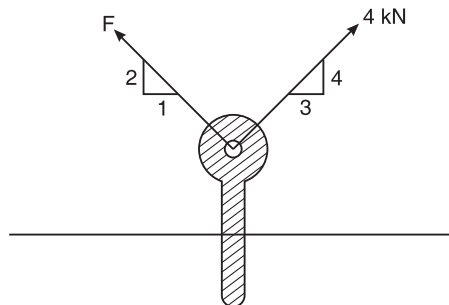

Figure Q2(c)(ii)

3. (a) Choose the correct answers for the following: **(04 Marks)**
- (i) If two concurrent forces each of P act at right angles to each other, their resultant will be equal to
(A) $P\sqrt{2}$ (B) $2\sqrt{P}$ (C) $4P$ (D) P
- (ii) The technique of finding the resultant of a system of forces is called
(A) Composition (B) Resolution
(C) Equilibrium (D) None of these

- (iii) In a coplanar concurrent force system, if $\Sigma V = 0$, then the resultant is
- (A) Moment of the force system
 - (B) Vertical
 - (C) Horizontal
 - (D) None of these
- (iv) If two forces act at an angle of 120° , the greater force is 50 N and their resultant is perpendicular to smaller force, the magnitude of smaller force is
- (A) 43.33 N
 - (B) 32.50 N
 - (C) 25 N
 - (D) None of these
- (b) Determine the resultant force acting on the structure at point 'O' both in magnitude and direction for the system of forces shown in Figure Q3(b). **(06 Marks)**

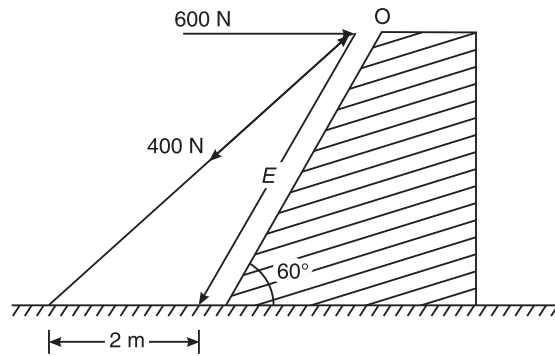

Figure Q3(b)

- (c) Determine the magnitude, direction and point of application of the resultant force for the system of forces shown in Figure Q3(c) with respect to point 'O'. **(10 Marks)**

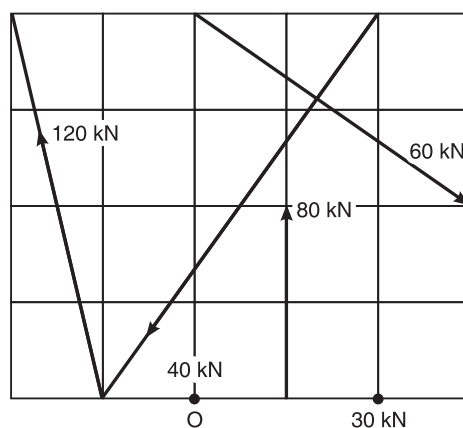

Figure Q3(c)

388 EXAMINATION PAPERS OF VTU

4. (a) Choose the correct answers for the following: **(04 Marks)**
- (i) Centroid of plane is the point at which
 - (A) Weight of the body is concentrated
 - (B) Mass of the body is concentrated
 - (C) Surface area of the body is concentrated
 - (D) All of these
 - (ii) An axis over which one half of the plane figure is just the mirror of the other half is called
 - (A) Bottom axis
 - (B) Axis of symmetry
 - (C) Unsymmetrical axis
 - (D) All of these
 - (iii) The centroid of the plane lamina will not be at its geometrical centre if it is a
 - (A) Rectangle
 - (B) Square
 - (C) Circle
 - (D) Right angle triangle
 - (iv) Centroid of a quarter of circular lamina lies from diameter line at a distance of
 - (A) $4R/3\pi$
 - (B) $R/3\pi$
 - (C) $2R/3\pi$
 - (D) None of these
- (b) Locate the centroid of a triangle by the method of integration.
- (c) Locate the centroid of the shaded area shown in Figure Q4(c) with respect to OX and OY. All dimensions are in mm. **(10 Marks)**

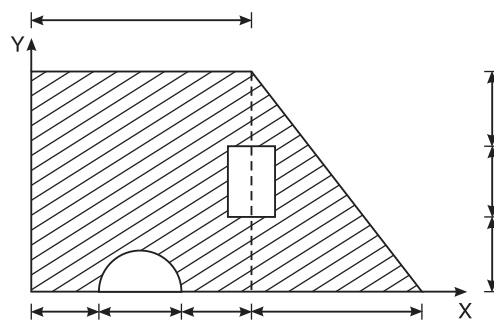

Figure Q4(c)

PART-B

5. (a) Choose the correct answers for the following: **(04 Marks)**
- (i) A free body diagram is a diagram
 - (A) Drawn by free hand
 - (B) Represents a floating body
 - (C) Separating the body from its surrounding and replacing with force vector
 - (D) All of these
 - (ii) The Lami's theorem can be applied only when number of unknown forces are
 - (A) Two
 - (B) Three
 - (C) Five
 - (D) None of these

- (iii) If a body is in equilibrium, it is concluded that
(A) No force is acting (B) Resultant is zero
(C) Moment about any point is zero (D) Both (B) and (C)
- (iv) For a smooth spherical surface reaction acts
(A) Horizontal to plane of contact
(B) Inclined to plane of contact
(C) Perpendicular to plane of contact
(D) None of these
- (b) An electric bulb weighing 150 N is suspended between wall and the roof by two wires as shown in Figure Q5(b). Determine the tension in the wires using Lami's theorem.

(06 Marks)

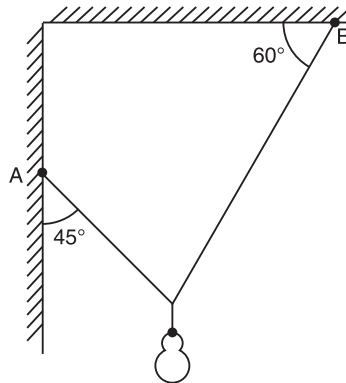

Figure Q5(b)

- (c) Find the reaction at the contact surfaces for two identical cylinders weighing 1000 N each as shown in Figure Q5(c).

(10 Marks)

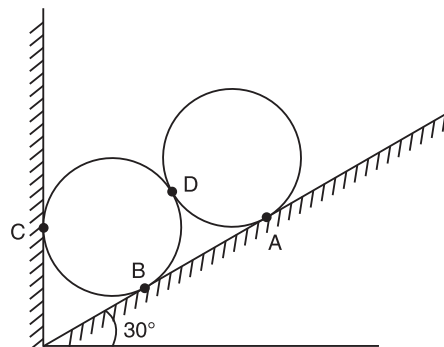

Figure Q5(c)

6. (a) Choose the correct answers for the following: (04 Marks)
- (i) Reaction line at roller support with respect to plane of contact is
(A) Oblique (B) Perpendicular
(C) Inclined (D) None of these

390 EXAMINATION PAPERS OF VTU

- (ii) When a load acts at constant rate over given length of a beam is called
(A) point load (B) UDL (C) UVL (D) All of these
 - (iii) At the fixed end of Cantilever, the number of unknowns reaction components are
(A) 1 (B) 2 (C) 3 (D) 4
 - (iv) Minimum number of members required to form a simple truss is
(A) 2 (B) 3 (C) 4 (D) 5
- (b) Define perfect and imperfect truss. Hence list the assumptions made in the analysis of simple truss. **(06 Marks)**
- (c) Determine the reaction components for the loaded beam shown in Figure Q6(c). **(10 Marks)**

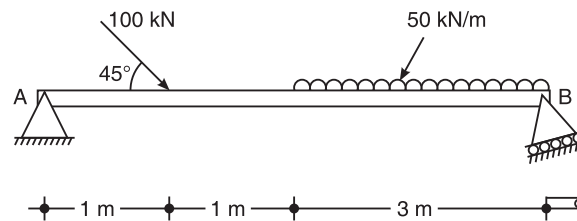

Figure Q6(c)

7. (a) Choose the correct answers for the following: **(04 Marks)**
- (i) The maximum frictional force developed when the body just begins to slide is called
(A) Limiting friction (B) Rolling friction
(C) Static friction (D) None of these
 - (ii) Compared to static friction, kinetic friction is
(A) Larger (B) Equal (C) Smaller (D) None of these
 - (iii) Angle of friction is the angle between
(A) Normal reaction and friction force
(B) Normal reaction and resultant
(C) Weight of the body and friction force
(D) Normal reaction and weight of the body
 - (iv) The force of friction depends on
(A) Area of contact (B) Roughness of contact surface
(C) Both (A) and (B) (D) None of these
- (b) Explain briefly **(06 Marks)**
- (i) Angle of repose
 - (ii) Cone of friction
- (c) A ladder weighing 200 N is supported as shown in Figure Q7(c). If a man weighing 650 N climbs to the top of the ladder, determine the inclination of the ladder with the floor at which the ladder is to be placed to prevent slipping. Take $\mu = 0.25$ for all contact surfaces. **(10 Marks)**

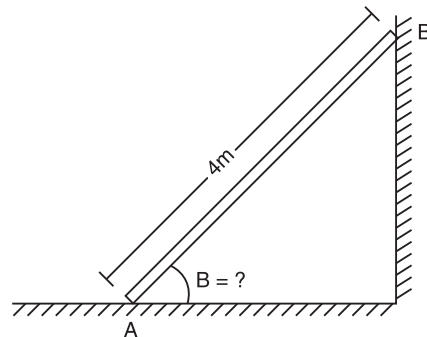

Figure Q7(c)

8. (a) Choose the correct answers for the following: (04 Marks)

- (i) Moment of inertia is
 - (A) Second moment of area
 - (B) First moment of area
 - (C) Third moment of area
 - (D) None of these
- (ii) M.I. of circular section about centroidal axis is
 - (A) $\pi D^4/32$
 - (B) $\pi D^4/48$
 - (C) $\pi D^4/64$
 - (D) $\pi D^4/128$
- (iii) The unit of radius of gyration is
 - (A) mm
 - (B) mm^2
 - (C) mm^3
 - (D) mm^4
- (iv) M.I. of a square of side 'B' about its centroidal axis is
 - (A) $B^4/8$
 - (B) $B^4/12$
 - (C) $B^4/36$
 - (D) $B^4/48$

(b) State and prove parallel axis theorem. (06 Marks)

(c) Determine radius of gyration of shaded area shown in Figure Q8(c) about the base AB. (10 Marks)

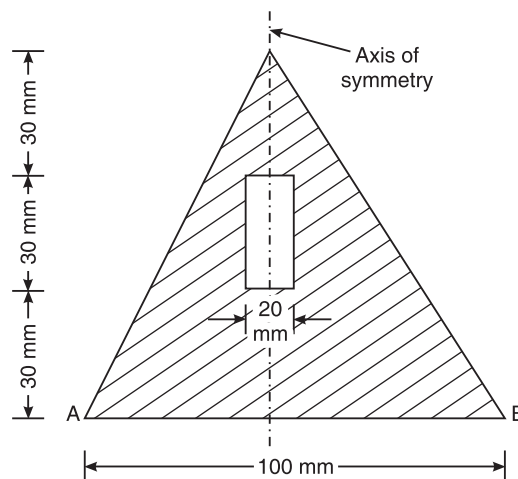

Figure Q8(c)

392 EXAMINATION PAPERS OF VTU

First and Second Semester B.E. Degree Examination, June 2012

**ELEMENTS OF CIVIL ENGINEERING AND
ENGINEERING MECHANICS**

Time: 3 hrs.

Max. Marks: 100

- Note:** 1. Answer any FIVE full questions, choosing at least two from each part.
2. Answer all objective type questions only in OMR sheet page 5 of the answer booklet.
3. Answer to objective type questions on sheets other than OMR will not be valued.

PART–A

1. (a) Select the correct answer: **(04 Marks)**
- (i) A Bascule bridge is a
 - (A) Floating bridge
 - (B) Arch bridge
 - (C) Suspension bridge
 - (D) Movable bridge
 - (ii) Geotechnical engineering involves the study of
 - (A) Water
 - (B) Soil
 - (C) Air
 - (D) All of these
 - (iii) Pick up a structure in which an inspection gallery is formed:
 - (A) Dam
 - (B) Bridge
 - (C) Harbour
 - (D) Airport
 - (iv) The part of civil engineering which deals with waste water and solid waste is called
 - (A) Transportation Engineering
 - (B) Structural Engineering
 - (C) Sanitary Engineering
 - (D) Surveying
- (b) Explain the role of civil engineer in the infra–structural development of a nation. **(06 Marks)**
- (c) Explain different types of roads. **(06 Marks)**
- (d) Give the difference between Earthen dam and gravity dam. **(04 Marks)**
2. (a) Select the correct answer: **(04 Marks)**
- (i) The moment of a force about a moment centre is a measure of its
 - (A) Translatory effect
 - (B) Rotational effect
 - (C) Both A and B
 - (D) None of these
 - (ii) Effect of force on a body depends on
 - (A) Magnitude
 - (B) Direction
 - (C) Position
 - (D) All of these
 - (iii) Couple means two forces acting parallel and
 - (A) Equal in magnitude and in same direction
 - (B) Not equal in magnitude but in same direction
 - (C) Equal in magnitude but opposite in direction
 - (D) None of these

- (iv) The magnitude of the moment is _____ when a force is applied perpendicular to a lever
 (A) Maximum (B) Minimum
 (C) Zero (D) Negative
- (b) State and explain principle of transmissibility of a force. **(04 Marks)**
- (c) Explain equivalent force–couple system. **(04 Marks)**
- (d) Determine angle θ ($0 \leq \theta \leq 180^\circ$) for the force $F = 200$ N shown in Figure Q.2(d), so that it produces (a) maximum moment about 'A' and (b) minimum moment about 'A'.
 Determine maximum and minimum moments. **(08 Marks)**

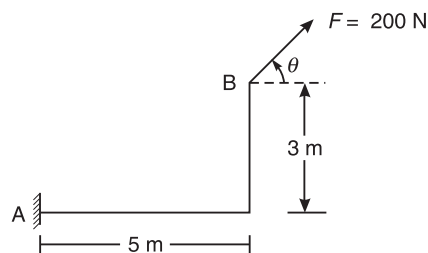

Figure Q.2(d)

3. (a) Select the correct answer: **(04 Marks)**
- (i) The process of finding the resultant of a system of forces is called
 (A) Resultant (B) Resolution
 (C) Composition (D) None of these
- (ii) If two forces P and Q ($P > Q$) act on the same straight line but in opposite direction their resultant is
 (A) $P + Q$ (B) $\frac{P}{Q}$ (C) $Q - P$ (D) $P - Q$
- (iii) Component of a force at a right angles to its line of action is
 (A) Zero (B) Positive
 (C) Negative (D) None of these
- (iv) In a coplanar concurrent force system if $\Sigma H = 0$, then the resultant is
 (A) Horizontal (B) Vertical
 (C) Moment (D) None of these
- (b) The 26 kN force is the resultant of two forces, one of which is shown in Figure Q.3(b). Determine the other force. **(08 Marks)**
- (c) A rigid plate is subjected to the forces as shown in Figure Q.3(c), compute resultant of forces and position of resultant force with respect to centroid point 'O' of the plate. **(08 Marks)**

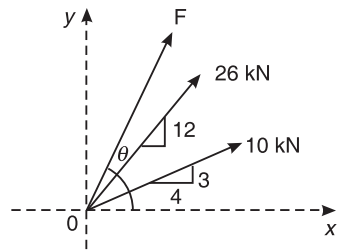

Figure Q.3(b)

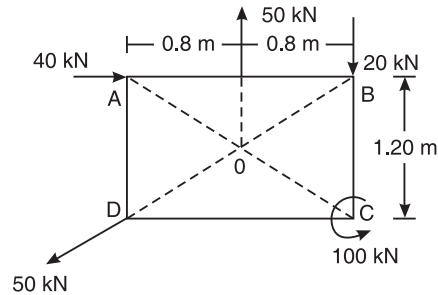

Figure Q.3(c)

4. (a) Select the correct answer: (04 Marks)

(i) Centroid of semicircle of radius ' R ' about its centroidal axis parallel to diametric axis is

- (A) $\frac{3R}{4\pi}$ (B) $\frac{3R}{8\pi}$ (C) $\frac{4R}{\pi}$ (D) $\frac{4R}{3\pi}$

(ii) An axis over which one half of plane figure is just mirror image of the other half is

- (A) Axis of symmetry (B) Unsymmetrical axis
(C) Bottom most axis (D) None of these

(iii) Moment of total area about its centroidal axis is

- (A) Twice the area (B) Three times the area
(C) Zero (D) None of these

(iv) The centroid of a triangular lamina of height ' h ' is situated at a distance ____ from its apex.

- (A) $\frac{h}{3}$ (B) $\frac{2h}{3}$ (C) $\frac{h}{2}$ (D) $\frac{h}{4}$

(b) Locate the centroid of the shaded area shown in Figure Q.4(b), with respect to point '0'.

(08 Marks)

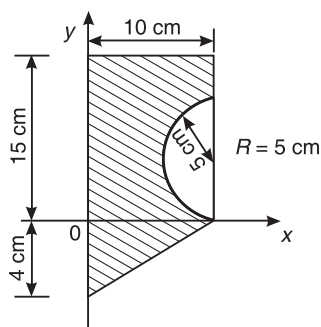

Figure Q.4(b)

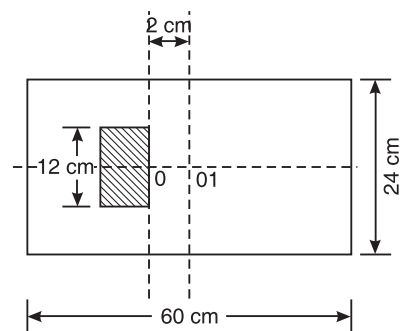

Figure Q.4(c)

- (c) The centroid of the rectangular area requires to be shifted from point 'O' to O1 (2 cms). This is accomplished by removing hatch portion which is 12 cm deep and symmetrical about X-X axis. Determine area of hatched portion shown in Figure Q.4(c). **(08 Marks)**

PART-B

5. (a) Select the correct answer: **(04 Marks)**

- (i) The force which is equal and opposite to resultant is
 (A) Resultant force (B) Moment
 (C) Equilibrant (D) None of these
- (ii) A particle acted upon by the two forces of equal magnitude is in equilibrium. The angle between the forces is
 (A) 0° (B) 90° (C) 180° (D) 45°
- (iii) The necessary condition of equilibrium of a coplanar concurrent force system is algebraic sum of must be zero.
 (A) Horizontal and Vertical forces
 (B) Moment of forces
 (C) Horizontal vertical and moment of forces
 (D) None of these
- (iv) Lami's equation can be applied when number of unknown forces are ____
 (A) Two (B) Five (C) Four (D) Three

- (b) Determine the angle θ for the system of strings ABCD in equilibrium as shown in Figure Q.5(b). **(08 Marks)**

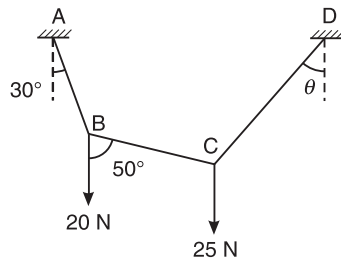
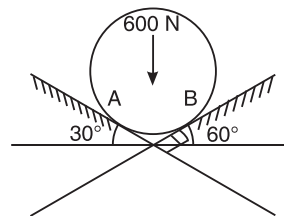
**Figure Q.5(b)****Figure Q.5(c)**

- (c) A cylinder of weight 600 N rests on smooth surfaces as shown in Figure Q.5(c). Determine the reactions at contact points. The contact surfaces are perpendicular to each other. **(08 Marks)**

6. (a) Select the correct answer: **(04 Marks)**

- (i) A cantilever beam is one in which ____
 (A) Both ends are fixed
 (B) Both ends are hinged
 (C) One end is fixed and other end is simply supported
 (D) One end is fixed and other end is free.

396 EXAMINATION PAPERS OF VTU

- (ii) A truss is perfect when
 - (A) $m = 2j - 3$
 - (B) $2j = m + 3$
 - (C) $m = 3j - 2$
 - (D) $2j = m - 3$
 - (iii) The minimum number of members to form a perfect truss is
 - (A) 1
 - (B) 2
 - (C) 3
 - (D) 4
 - (iv) The number of reaction components at a hinged end of a beam
 - (A) zero
 - (B) 2
 - (C) 3
 - (D) 1
- (b) A pin joined truss is loaded and supported as shown in Figure Q.6(b). Determine forces in members BC, GF and CG and nature of forces. **(08 Marks)**
- (c) Find the reactions for the beam supported and loaded as shown in Figure Q.6(c). **(08 Marks)**

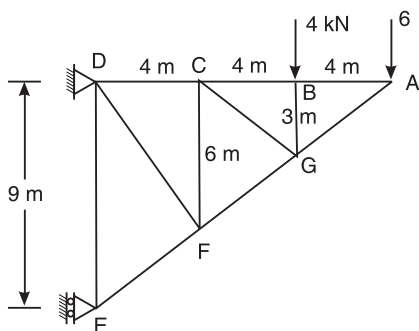

Figure Q.6(b)

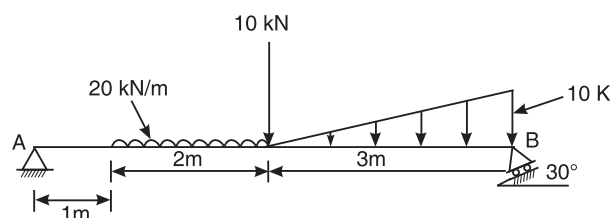

Figure Q.6(c)

7. (a) Select the correct answer: **(04 Marks)**
- (i) Compared to static friction, kinetic friction is
 - (A) greater
 - (B) smaller
 - (C) very large
 - (D) zero
 - (ii) Frictional force acts _____ to the surfaces in contact
 - (A) Tangential
 - (B) Normal
 - (C) Inclined
 - (D) None of these
 - (iii) The force of friction depends on
 - (A) Area of contact
 - (B) Roughness of surfaces
 - (C) Both area of contact and roughness of surfaces
 - (D) None of these
 - (iv) At the point of impending motion, the static frictional force is
 - (A) Zero
 - (B) Maximum
 - (C) Minimum
 - (D) Infinite
- (b) State laws of static friction. **(04 Marks)**
- (c) Briefly explain (i) Angle of repose (ii) Cone of friction. **(04 Marks)**

- (d) A ladder 7 m long weighing 300 N is resting against a wall at an angle of 60° to the horizontal ground. A man weighing 700 N climbs the ladder, at what position does he induce slipping. Take $\mu = 0.25$ for all contact surfaces. **(08 Marks)**

8. (a) Select the correct answer: **(04 Marks)**

- (i) Moment of inertia of a square of side 'b' about an axis through its centroid is

(A) $\frac{b^4}{12}$ (B) $\frac{b^4}{8}$ (C) $\frac{b^4}{36}$ (D) $\frac{b^3}{12}$

- (ii) Moment of inertia of a triangle of base 'b' and height 'h' about its base is

(A) $\frac{bh^3}{36}$ (B) $\frac{bh^4}{36}$ (C) $\frac{hb^3}{12}$ (D) $\frac{Bh^3}{12}$

- (iii) The unit of radius of gyration is

(A) mm (B) mm^2 (C) kN-m (D) mm^4

- (iv) Which of the following equation relating to radii of gyration is correct?

(A) $K_{zz} = K_{xx} + K_{yy}$ (B) $K_{xx} = K_{yy} + K_{zz}$
 (C) $K_{zz}^2 = K_{xx}^2 + K_{yy}^2$ (D) None of these

(b) State and prove parallel axis theorem. **(06 Marks)**

(c) Determine moment of inertia and radius of gyration of the area shown in Figure Q.8(c), about base AB and centroidal axis parallel to AB. **(10 Marks)**

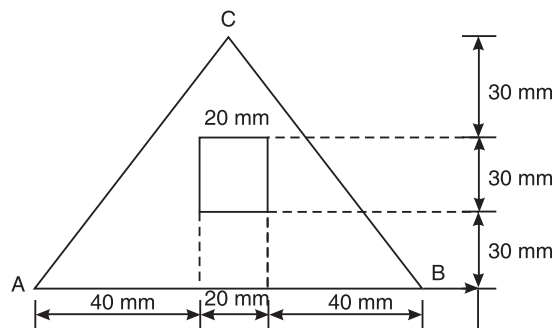

Figure Q.8(c)

First and Second Semester B.E. Degree Examination, December 2011

**ELEMENTS OF CIVIL ENGINEERING AND
ENGINEERING MECHANICS**

Time: 3 hrs.

Max. Marks: 100

- Note:** 1. Answer any FIVE full questions choosing at least two from each part.
2. Answer all objective type questions only in OMR sheet page 5 of the answer booklet.
3. Answer to objective type questions on sheets other than OMR will not be valued.

PART-A

1. (a) Choose the correct answer: **(04 Marks)**
- (i) The discipline which deals with sub-structure is called as
 - (A) Structural Engg.
 - (B) Environmental Engg.
 - (C) Geo-technical Engg.
 - (D) None of these
 - (ii) The minimum breadth of a national highway is
 - (A) 45 m
 - (B) 15 m
 - (C) 30 m
 - (D) 60 m
 - (iii) Krishnaraja Sagar dam is an example for
 - (A) Gravity dam
 - (B) Earth dam
 - (C) Arch dam
 - (D) None of these
 - (iv) The Howrah bridge and K.R. Puram bridge are the examples for
 - (A) Arch bridge
 - (B) Hanging bridge
 - (C) Skew bridge
 - (D) Steel bridge
- (b) Explain how the infrastructure development will help the growth of economy of the country. **(05 Marks)**
- (c) Explain the following parts of a highway with a neat sketch:
(i) Kerb (ii) Camber (iii) Formation width **(06 Marks)**
- (d) Draw a neat sketch of the cross-section of the earthen dam. **(05 Marks)**
2. (a) Choose the correct answer: **(04 Marks)**
- (i) In the SI system, the unit of force and power are respectively
 - (A) Newton & Watt
 - (B) Newton & Joule
 - (C) Newton & Pascal
 - (D) Newton & Hertz
 - (ii) The principle of transmissibility can be applied when the body is treated as
 - (A) Particle
 - (B) Rigid body
 - (C) Deformable
 - (D) a continuum
 - (iii) Mathematical statement of the law of triangle of forces is
 - (A) Sine law
 - (B) Cosine law
 - (C) Law of parallelogram of forces
 - (D) Law of polygon of forces

- (iv) The action of a given system of forces on a rigid body will no way be changed if we add or subtract from them another system of forces in equilibrium is called
 (A) Law of superposition (B) Law of transmissibility
 (C) Free body diagram (D) Law of gravitational force
- (b) List and explain the concepts of Engineering Mechanics. **(06 Marks)**
- (c) In a triangle ABC, the sides AB, BC and AC are of distances 6 m, 8 m and 10 m respectively. A force at 'A' produces a clockwise moment of 90 kN-m at B and an anticlockwise moment of 45 kN-m at C. Find the magnitude and direction of the force. **(10 Marks)**
3. (a) Choose the correct answer: **(04 Marks)**
- (i) Two forces equal in magnitude act at a point. The angle between the lines of action of these two forces is 60° . If the resultant of these two force is 50 N, the magnitude of the force is
 (A) 25.88 N (B) 50 N (C) 28.87 N (D) 25 N
- (ii) The angles between two forces to make their resultant a minimum and a maximum respectively are
 (A) 0 & 90 (B) 180 & 90 (C) 180 & 0 (D) 0 & 270
- (iii) A bar under tension is called as
 (A) Strut (B) Tie
 (C) Flexible string (D) None of these
- (iv) The resultant of two forces P & Q is 'R' which acts at right angle to the force P. Then the angle between P & Q is
 (A) $\cos^{-1}(-P/Q)$ (B) $\cos^{-1}(-Q/P)$ (C) $\sin^{-1}(-P/Q)$ (D) $\sin^{-1}(-Q/P)$
- (b) A vehicle is pulled by means of two ropes as shown in Figure Q.3(b). If the resultant pull is 1500 N, find the angle θ and the force F. **(06 Marks)**

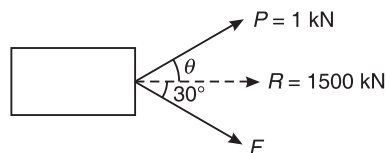

Figure Q.3(b)

- (c) The force 390 N, is shown in Figure Q.3(c), is the resultant of four forces. Out of them, 3 forces are shown in the Figure Q.3(c). Find the magnitude and direction of the force and its position with respect to point A. **(10 Marks)**

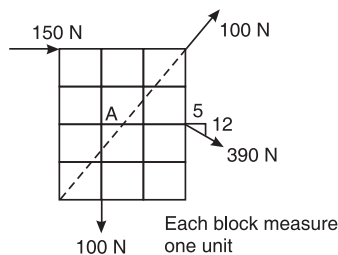

Figure Q.3(c)

400 EXAMINATION PAPERS OF VTU

4. (a) Choose the correct answer:

(i) Centroid refers to a figure, which has

- (A) Volume (B) Weight
(C) Plane lamina (D) None of these

(ii) The centroid of an equilateral triangle of side “b” from the base is

- (A) $\frac{h}{3}$ (B) $\frac{b}{2}$ (C) $\frac{\sqrt{3}}{6}b$ (D) $\frac{\sqrt{5}}{2}b$

(iii) Centroid should always lie in the

- (A) lamina (B) outside the lamina
(C) either A or B (D) None of these

(iv) While defining the radius of gyration the object is considered as

- (A) thin lamina (B) irregular object
(C) regular object of size L × B (D) None of these

(b) Derive an expression for the centroid of the semi circular lamina, when its base is placed on the ordinate. **(06 Marks)**

(c) Locate the centroid of the lamina shown in Figure Q.4(c). **(10 Marks)**

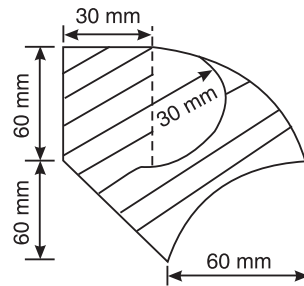

Figure Q.4(c)

PART-B

5. (a) Choose the correct answer:

(04 Marks)

(i) The force which cancels the effect of the force system is known as

- (A) Resultant (B) Neural force
(C) Balancing force (D) Equilibrant

(ii) Reaction force at the contact surface is

- (A) Internal force (B) Applied force
(C) either A or B (D) Neither A nor B

(iii) If the resultant of all the forces is not equal to zero, then the object will have

- (A) Rotary motion (B) Translatory motion
(C) Both A and B (D) None of these

- (iv) The object is in equilibrium means
 (A) $R = 0$; moves in the opposite direction or remains at the same point.
 (B) $R = 0$; moves in the same direction or remains at the same point.
 (C) $\Sigma H = +P$ & $\Sigma V = -P$; and moves in its same direction.
 (D) None of the above.
- (b) In the Figure Q.5(b), determine the value 'h' if $W = 80$ N, $P = 100$ N and $d = 20$ cm. **(06 Marks)**

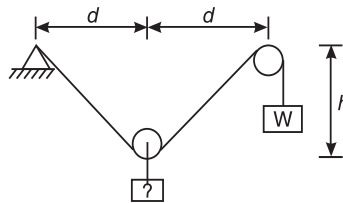

Figure Q.5(b)

- (c) The Figures Q.5(c) (i) and (ii) show two alternatives for lifting a 80 cm square box, using a sling 7 m long. The weight of the box is 200 N. Which alternative would place lesser tension? **(10 Marks)**

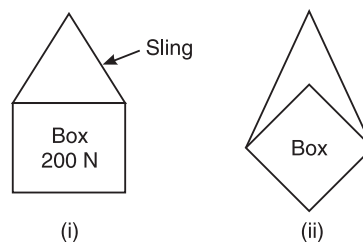
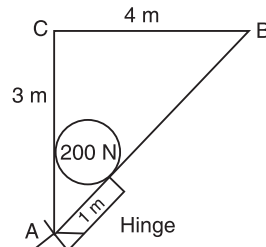

Figure Q.5(c)

6. (a) Choose the correct answer: **(04 Marks)**
- (i) A beam AB of length 4 m supports 4 kN from the left support, at a distance of 3 m. Then, the reactions in supports A & B respectively are
 (A) 3 & 1 (B) 3.5 & 0.5 (C) 2 & 2 (D) 1 & 3
- (ii) A beam has one end fixed and other end is simply supported; then it is called as a
 (A) Fixed beam (B) Propped cantilever
 (C) Simply supported (D) Overhung beam
- (iii) A water tank placed on a beam produces _____ load.
 (A) UVL (B) Point (C) UDL (D) None of these
- (iv) The number of reactions in the roller support are
 (A) 1 (B) 2 (C) 3 (D) 0
- (b) Explain different type of loads applied on a beam. **(04 Marks)**

402 EXAMINATION PAPERS OF VTU

- (c) Determine the reaction at the hinge and tension in string in the Figure Q.6(c).
- (07 Marks)**

**Figure Q.6(c)**

- (d) Determine the forces exerted on the cylinder at B and C shown in Figure Q.6(d).
- (05 Marks)**

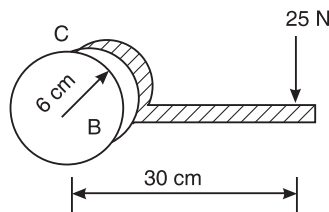
**Figure Q.6(d)**

7. (a) Choose the correct answer:
- (04 Marks)**

- (i) Coulomb's law of friction can be applied to
 (A) Fluid friction (B) Lubricated friction
 (C) Dry friction (D) Fluid structure interaction
- (ii) At the point of impending motion, the static friction is
 (A) zero (B) maximum
 (C) minimum (D) infinite
- (iii) Angle of friction is given as
 (A) $\sin^{-1} \mu$ (B) $\cos^{-1} \mu$ (C) $\tan^{-1} \mu$ (D) $\cot^{-1} \mu$
- (iv) When a block of weight W , resting on a rough inclined plane of inclination θ does not slide, then the frictional force acting on it is
 (A) $W \sin \theta$ (B) $W \cos \theta$ (C) $\mu W \sin \theta$ (D) $\mu W \cos \theta$
- (b) Define (i) coefficient of friction (ii) cone of friction (iii) angle of friction. **(06 Marks)**
- (c) A homogeneous bar of length l placed between two perpendicular rough walls AB & CD

as shown in Figure Q.7(c). Show that the angle of inclination is $\tan^{-1} \left[\frac{1 - \mu\mu'}{2\mu} \right]$.

(10 Marks)

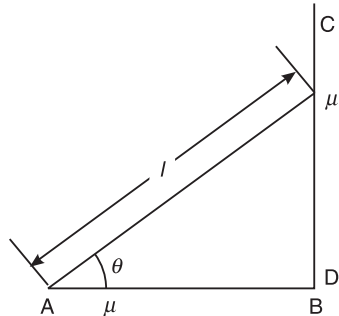

Figure Q.7(c)

8. (a) Choose the correct answer: (04 Marks)

(i) The moment of inertia of a square of side 'a' on the diagonal axis is

(A) $\frac{a^4}{6}$ (B) $\frac{a^4}{12}$ (C) $\frac{a^4}{8}$ (D) $\frac{a^4}{10}$

(ii) Which of the following physical quantities can be positive or negative?

(A) I_{xx} (B) I_{yy} (C) I_{xy} (D) I_p

(iii) I_{zz} of right angle of a triangle of base 'b' and height 'h' is

(A) $\frac{bh}{36}[h^2 + b^2]$ (B) $\frac{bh}{36}[h^2 - b^2]$

(C) $\frac{bh}{36}[h - b]^2$ (D) $\frac{bh}{36}[h + b]^2$

(iv) The polar moment of inertia of a circular area of diameter D is

(A) $\frac{\pi D^4}{64}$ (B) $\frac{\pi D^4}{32}$ (C) $\frac{\pi D^4}{16}$ (D) $\frac{\pi D^4}{8}$

(b) Find the moment of inertia on the symmetrical axis of the isosceles triangle.

(06 Marks)

(c) Determine the distance between two plates of 2 cm × 8 cm, so that $I_{xx} = I_{yy}$. Refer Figure Q.8(c). (10 Marks)

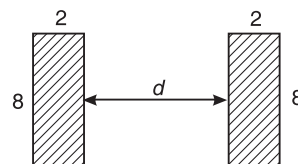

Figure Q.8(c)

First and Second Semester B.E. Degree Examination, June/July 2011

**ELEMENTS OF CIVIL ENGINEERING AND
ENGINEERING MECHANICS**

Time: 3 hrs.

Max. Marks: 100

- Note:**
1. Answer any FIVE full questions, choosing at least two from each part.
 2. Answer all objective type questions only in OMR sheet page 5 of the answer booklet.
 3. Answer to objective type questions on sheets other than OMR will not be valued.

PART-A

1. (a) Choose your answers for the following: **(04 Marks)**
- (i) Geotechnical engineering involves the study of
(A) Building (B) Soil (C) Air (D) All of these
 - (ii) Building tanks and dams and carrying stored water to field is known as
(A) Structural engineering
(B) Environmental engineering
(C) Water resources and irrigation engineering
(D) Construction technology
 - (iii) The structure which provides passage over the obstacles like valley, river without closing the way underneath is:
(A) Dam (B) Bridge (C) Harbour (D) Airport
 - (iv) Highway which are superior to National Highways and are provided wherever volume of traffic is very high are:
(A) State highways (B) High volume roads
(C) Airways (D) Expressways
- (b) Explain briefly the scope of civil engineering in: **(10 Marks)**
- (i) Water resources engineering
 - (ii) Geotechnical engineering
- (c) Explain different types of roads. **(06 Marks)**
2. (a) Choose your answers for the following: **(04 Marks)**
- (i) Which of the following is the basic concept of mechanics:
(A) Charge (B) Power (C) Force (D) Energy
 - (ii) When more than three concurrent forces are in equilibrium, select the condition that is satisfied.
(A) All the forces must have equal magnitude
(B) Polygon representing the forces will not close
(C) The last side of the polygon will represent the resultant
(D) Polygon representing the forces will close

- (iii) Effect of a force on a body depends upon its:
 (A) Direction (B) Position (C) Magnitude (D) All the above
- (iv) Forces coexist on a plane and all the forces act helter-skelter over the body. These are
 (A) Coplanar non-concurrent forces
 (B) Coplanar concurrent forces
 (C) Coplanar parallel forces
 (D) Non-coplanar non-concurrent forces
- (b) State and explain basic idealization in mechanics. **(06 Marks)**
- (c) Define a couple. Mention its characteristics. **(04 Marks)**
- (d) A 100 N vertical force is applied to the end of a lever which is attached to a shaft as shown in Figure Q.2(d), determine **(06 Marks)**
- The moment of force about 'O'.
 - The horizontal force applied at 'A' which creates same moment about 'O'.
 - The smallest force applied at 'A' which creates same moment about 'O'.

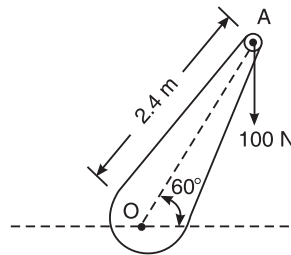

Figure Q.2(d)

3. (a) Choose your answers for the following: **(04 Marks)**
- If two equal forces of magnitude ' p ' act at an angle ' θ ', their resultant will be
 (A) $2p \cos \theta/2$ (B) $p \tan \theta/2$ (C) $2p \sin \theta/2$ (D) $p \cos \theta/2$
 - The simplest resultant of a plane force system is always
 (A) A single force (B) A wrench
 (C) A single moment (D) A single force or a single moment
 - The angle between two forces to make their resultant a minimum and maximum respectively are:
 (A) 0° and 90° (B) 180° and 90° (C) 90° and 180° (D) 180° and 0°
 - The moment of a force about any point is numerically equal to _____ times the area of the triangle whose base is the line representing the force and vertex is the point about which the moment is taken
 (A) Half (B) Same (C) Twice (D) Thrice
- (b) State and prove Varignon's theorem of moments. **(10 Marks)**

406 EXAMINATION PAPERS OF VTU

- (c) Two forces acting on a body are 500 N and 1000 N as shown in Figure Q.3(c). Determine the third force F such that the resultant of all the three forces is 1000 N directed at 45° to the x -axis. **(06 Marks)**

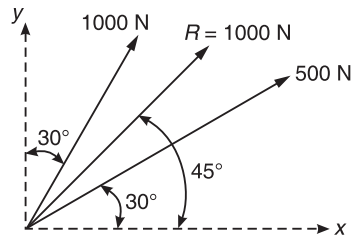

Figure Q.3(c)

4. (a) Choose your answers for the following: **(04 Marks)**

(i) The first moment of area of a semicircular area about its diameter d is given by

(A) $\frac{d^3}{12}$ (B) $\frac{d^3}{24}$ (C) $\frac{d^3}{6}$ (D) $\frac{d^3}{36}$

(ii) Centroid of a triangular area of base ' b ' and height ' h ' taken about an axis coincident with the base is given by

(A) $\frac{bh^3}{12}$ (B) $\frac{b^2h}{6}$ (C) $\frac{bh^2}{6}$ (D) $\frac{h}{3}$

(iii) Moment of total area about its centroidal axis is

- (A) Twice the area (B) Three times the area
(C) Zero (D) None of these

(iv) Centroid conveys some clue about

- (A) The orientation of a surface (B) Centre of a body
(C) Shape and disposition of the area (D) Area of cross-section

- (b) Determine the centroid of semicircle by the method of integration. **(06 Marks)**

- (c) With reference to the co-ordinate axis x and y , locate the centroid of the area shown in Figure Q.4(c). **(10 Marks)**

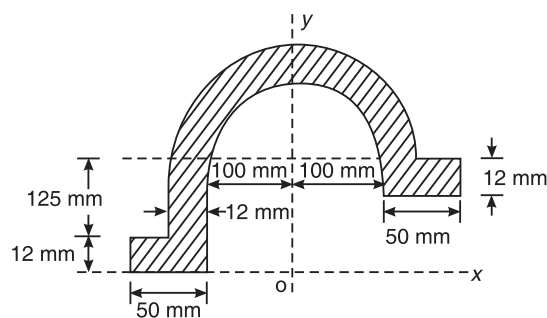

Figure Q.4(c)

5. (a) Choose your answers for the following: **(04 Marks)**
- The force that cancels the effects of the force system acting on the body is known as
 - Resultant
 - Neutral force
 - Balancing force
 - Equilibrant
 - If the sum of all the forces acting on a body is zero it may be concluded that the body
 - Must be in equilibrium
 - Cannot be in equilibrium
 - May be equilibrium provided the forces are concurrent
 - May be in equilibrium provided the forces are parallel
 - For a smooth spherical surface reaction acts
 - Horizontal to the plane of contact
 - Inclined to the plane of contact
 - Perpendicular to the plane of contact
 - None of the above
 - A system that possesses a resultant
 - Will be equilibrium
 - Will be under rest
 - Will not be in equilibrium
 - None of these
- (b) Define free body diagram. Describe types of forces acting on a body. Explain them briefly. **(06 Marks)**
- (c) Cylinder 'A' of diameter 200 mm and cylinder B of diameter 300 mm are placed in a trough as shown in Figure Q.5(c). If the cylinder A weighs 800 N and B weighs 1200 N, determine the reactions developed at contact surfaces P, Q, R and S. Assume all contact surfaces are smooth. **(10 Marks)**

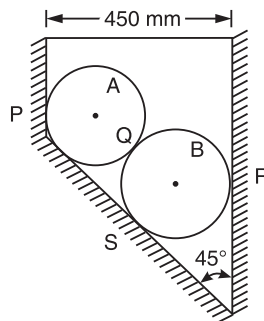

Figure Q.5(c)

6. (a) Choose your answers for the following: **(04 Marks)**
- Minimum number of members required to form a simple truss
 - 2
 - 3
 - 4
 - 5
 - In the method of joints for the analysis of forces in the member of truss, the number of equilibrium equations available at each joint are
 - 2
 - 3
 - 4
 - 5
 - For a system of coplanar parallel forces to be in equilibrium
 - The resultant force must vanish alone is sufficient
 - The resultant couple must vanish alone is sufficient

408 EXAMINATION PAPERS OF VTU

- (C) Both resultant force and the resultant couple must vanish
 (D) None of the above
- (iv) The beam is neither permitted to move in any direction nor allowed to rotate in the case of
 (A) Hinged support (B) Fixed support
 (C) Roller support (D) Simple support
- (b) Briefly explain the method of joints and method of sections used in the analysis of simple trusses. **(06 Marks)**
- (c) Determine the reactions at the support for the beam loaded shown in Figure Q.6(c). **(10 Marks)**

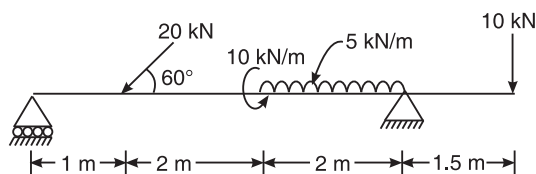

Figure Q.6(c)

7. (a) Choose your answers for the following: **(04 Marks)**
- (i) A body of weight Q is placed on an inclined rough plane. The inclination of the plane with the horizontal is less than the angle of friction. The body will
 (A) Be in motion (B) Move downwards
 (C) Be in equilibrium (D) Move upwards
- (ii) The angle which an inclined surface makes with the horizontal when a body placed on it is in verge of moving down, is called
 (A) Angle of repose (B) Angle of friction
 (C) Angle of inclination (D) None of these
- (iii) If ϕ = angle of friction and μ = coefficient of friction, then which equation is valid?
 (A) $\tan \phi = \mu$ (B) $\tan \phi = \frac{1}{\mu}$ (C) $\sin \phi = \mu$ (D) $\cos \phi = \mu$
- (iv) Angle of friction is the angle between
 (A) The incline and horizontal
 (B) The normal reaction and frictional force
 (C) The weight of the body and the friction force
 (D) Normal reaction and the resultant
- (b) Explain limiting friction, angle of repose and cone of friction. **(06 Marks)**
- (c) A uniform ladder of 4 m length rests against a vertical wall with which it makes an angle of 45° as shown in Figure Q.7(c). The coefficient of friction between the ladder and the floor is 0.5. If the man whose weight is one-half of that of ladder ascends it, how high will he be when the ladder slips? **(10 Marks)**

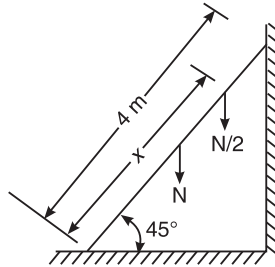

Figure Q.7(c)

8. (a) Choose your answers for the following: (04 Marks)

- (i) The moment of inertia of a body is
 - (A) Moment of its inertia
 - (B) The rotational moment acting on the body
 - (C) The rotational analogue of mass
 - (D) The inertial moment acting on the body
- (ii) The second moment of a plane area about any axis as compared to its second moment about the neutral axis
 - (A) Is always more
 - (B) Is always less
 - (C) Is equal
 - (D) Not equal
- (iii) Moment of inertia of a square of side a about an axis through its centre of gravity is
 - (A) $\frac{a^4}{4}$
 - (B) $\frac{a^4}{8}$
 - (C) $\frac{a^4}{12}$
 - (D) $\frac{a^4}{36}$
- (iv) The value of moment of inertia depends on
 - (A) Type of material
 - (B) Weight of material
 - (C) Density of material
 - (D) Cross-sectional dimensions

(b) State and prove parallel axis theorem. (06 Marks)

(c) Determine the second moment of area about horizontal centroidal axis for shaded area shown in Figure Q.8(c). Also find the radius of gyration about the same axis. Take $R_1 = 50$ mm and $R_2 = 20$ mm. (10 Marks)

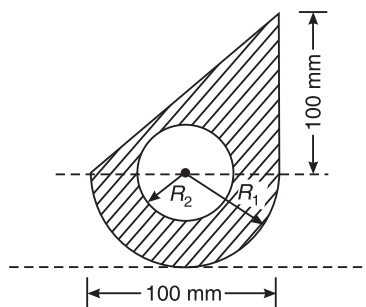

Figure Q.8(c)

410 EXAMINATION PAPERS OF VTU

First and Second Semester B.E. Degree Examination, June/July 2006 Scheme

**ELEMENTS OF CIVIL ENGINEERING AND
ENGINEERING MECHANICS**

Time: 3 hrs.

Max. Marks: 100

- Note:**
1. Answer any FIVE full questions, choosing at least two from each part.
 2. Answer all objective type questions only in OMR sheet page 5 of the Answer Booklet.
 3. Answers to objective type questions on sheets other than OMR will not be valued.

PART-A

1. (a) Select the correct answer: **(04 Marks)**
- (i) The topmost layer of the road over which the traffic moves is
(A) Edging (B) Wearing coat
(C) Bern (D) Pavement
 - (ii) The branch of civil engineering which deals with planning scheduling and execution of project is
(A) Geotechnical engineering
(B) Surveying
(C) Construction technology and management
(D) Structural engineering
 - (iii) The bridges of span between 8 m and 30 m are
(A) Minor bridges (B) Major bridges
(C) Culverts (D) Longspan bridges
 - (iv) Bituminous road is also known as
(A) Flexible pavement (B) Rigid pavement
(C) Kankar road (D) Moorum road
- (b) What is meant by surveying? Write a brief note on classification based on nature of field survey. **(08 Marks)**
- (c) Briefly explain the following specialization of civil engineering: **(08 Marks)**
- (i) Geotechnical engineering
 - (ii) Transportation engineering
2. (a) Select the correct answer: **(04 Marks)**
- (i) Branch of mechanics which deals with the motion of bodies referring to the forces causing the motion is
(A) Kinetics (B) Kinematics (C) Statics (D) Viscous fluid
 - (ii) Geometrical representation of moment of a force about a point is given by
(A) Area of triangle (B) Twice the area of triangle
(C) Thrice the area of triangle (D) Twice the area of rectangle
 - (iii) A single force which can nullify the effect of system of force is
(A) Resultant (B) Couple (C) Equilibrant (D) Moment

- (iv) If a given force system can be replaced by another system with exactly same net effect as given system, the two systems are said to be
 (A) Equivalent (B) Concurrent
 (C) Unequivalent (D) Continuous
- (b) Resolve 400 N force acting on a block as shown in Figure Q.2(b) into two components as given below. (a) Horizontal and vertical components. (b) Along the inclined plane and at right angles to the plane. **(08 Marks)**
- (c) Determine the moment of force about "A" shown in Figure Q.2(c). **(04 Marks)**

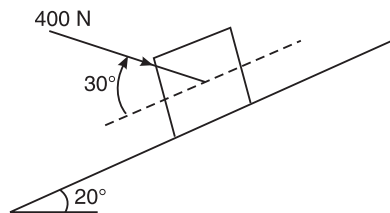

Figure Q.2(b)

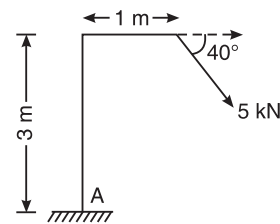

Figure Q.2(c)

- (d) Explain the principle of transmissibility of force. **(04 Marks)**
3. (a) Select the correct answer: **(04 Marks)**
- (i) Maximum and minimum resultant of two concurrent forces 20 kN and 12 kN are
 (A) 40 and 24 kN (B) 32 and 8 kN
 (C) 10 and 6 kN (D) None of these
- (ii) A couple consists of
 (A) Two equal parallel and opposite forces separated by a distance
 (B) Two equal and like parallel forces
 (C) Two unequal and like parallel forces
 (D) None of these
- (iii) Resultant of two unlike parallel forces 10 kN and 15 kN is
 (A) 25 kN (B) 5 kN (C) 150 kN (D) None of these
- (iv) Varignon's theorem is applicable to
 (A) Only coplanar force system
 (B) Only concurrent force system
 (C) Only nonconcurrent force system
 (D) Coplanar, concurrent and nonconcurrent systems
- (b) A dam section is shown in Figure Q.3(b). Determine the magnitude, direction and position of resultant with respect to 'O'. **(08 Marks)**
- (c) 2 kN force is the resultant of system of forces acting up along y-axis as shown in Figure Q.3(c). Determine the value of F and θ . **(08 Marks)**

412 EXAMINATION PAPERS OF VTU

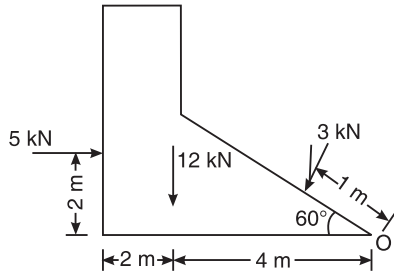

Figure Q.3(b)

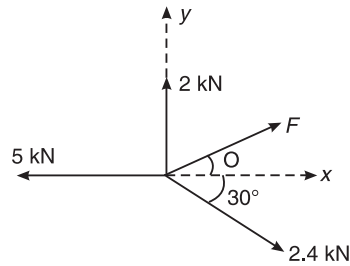

Figure Q.3(c)

4. (a) Select the correct answer: (04 Marks)

- (i) Centroid of a lamina must be
(A) Within lamina (B) Outside the lamina
(C) Not necessarily within lamina (D) None of these
- (ii) Centroid of a sector which is symmetrical about horizontal axis is given by
(A) $\frac{2R}{3\alpha} \sin \alpha$ (B) $\frac{4R}{3\alpha} \sin \alpha$ (C) $\frac{2R}{3\alpha} \cos \alpha$ (D) $\frac{2R}{4\alpha} \sin \alpha$
- (iii) The centroid of lamina is determined by the principle of
(A) Lami's theorem (B) Varignon's theorem
(C) Triangle law of forces (D) None of these
- (iv) One of the coordinates of centroid of a lamina symmetrical about vertical axis with a width of 200 mm and depth 150 mm is
(A) 100 mm (B) 75 mm (C) 200 mm (D) 150 mm

(b) Determine the centre of gravity of the lamina shown in Figure Q.4(b) with respect to O. (12 Marks)

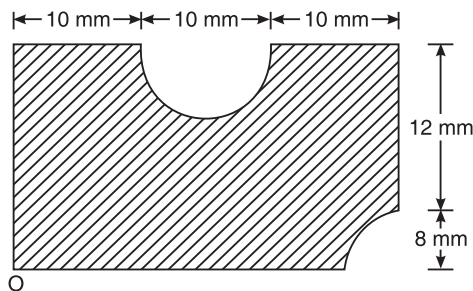

Figure Q.4(b)

(c) Locate the centroid of right angled triangle from first principles. (04 Marks)

PART B

5. (a) Select the correct answer: **(04 Marks)**

- (i) Lami's theorem is applicable for
 (A) Coplanar concurrent forces (B) Non coplanar concurrent forces
 (C) Coplanar non concurrent forces (D) Parallel forces
- (ii) Forces in equilibrium produces
 (A) Maximum resultant (B) Maximum moment
 (C) Zero resultant (D) Maximum torque
- (iii) A body lies in equilibrium under the action of three forces when
 (A) Resultant of any two forces is equal, opposite and collinear with third force
 (B) Resultant of any two forces is equal, parallel and collinear with third force
 (C) Resultant of any two forces is unequal, opposite and collinear with third force
 (D) All three forces are like parallel forces
- (iv) The reaction at the surface of contact of a sphere is
 (A) Parallel to the surface of contact
 (B) Normal to the surface of contact
 (C) Inclined to the surface of contact
 (D) None of the above

(b) Determine the forces in the wires shown in Figure Q.5(b). **(10 Marks)**

(c) A sphere of weight 300 N rests on an incline as shown in Figure Q.5(c). Determine the surface reactions. **(06 Marks)**

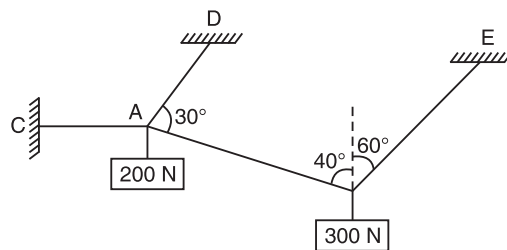

Figure Q.5(b)

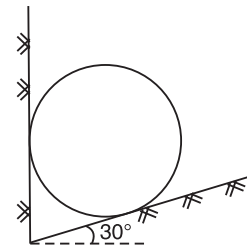

Figure Q.5(c)

6. (a) Select the correct answer: **(04 Marks)**

- (i) A beam supported by roller and hinge supports subjected to only vertical loads has
 (A) Vertical and horizontal reactions
 (B) Two vertical reaction
 (C) Two horizontal reactions
 (D) One vertical and a moment
- (ii) A determinate beam can be analyzed by applying maximum
 (A) Two conditions of equilibrium (B) Three conditions of equilibrium
 (C) Four conditions of equilibrium (D) One vertical and a moment

414 EXAMINATION PAPERS OF VTU

- (iii) Water in a tank is an example of
 (A) Point load (B) UDL (C) UVL (D) None of these
- (iv) A cantilever beam is one
 (A) Whose ends are fixed
 (B) Whose both ends are simply supported
 (C) Whose one end is fixed and the other simply supported
 (D) Whose one end is fixed and the other end free
- (b) What is the difference between determinate and indeterminate beams? **(04 Marks)**
- (c) Determine the support reactions for the beam shown in Figure Q.6(c). **(06 Marks)**

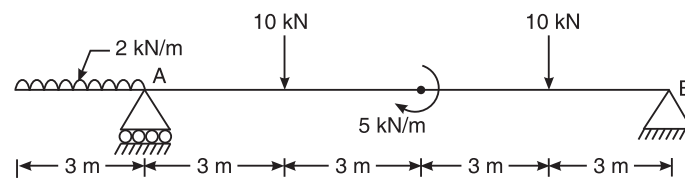

Figure Q.6(c)

- (d) Two men A and B carry a stone block weighing 2 kN, suspending the stone block on a horizontal beam and carrying it on their shoulders at each end. The beam is 2 m long and is of weight 580 N/m. A can carry maximum weight of 1.2 kN and B can carry a weight of 0.9 kN. Determine the distance at which the stone block is suspended from the end carried by A. **(06 Marks)**
7. (a) Select the correct answer: **(04 Marks)**
- (i) The force of friction is independent of
 (A) Force applied on body (B) Weight of body
 (C) Velocity of sliding (D) None of these
- (ii) The body remains at rest as long as the frictional force is
 (A) Equal to the force applied (B) Greater than the force applied
 (C) Less than the force applied (D) None of these
- (iii) Static friction is the friction between two surfaces
 (A) When no lubrication is used (B) When lubrication is used
 (C) When surfaces are heated (D) None of these
- (iv) Ratio of limiting force of friction to the normal reaction is
 (A) Angle of friction (B) Coefficient of friction
 (C) Angle of repose (D) None of these
- (b) What is meant by 'angle of repose'? Show that angle of repose is equal to angle of friction. **(08 Marks)**
- (c) A uniform ladder of weight 850 N and of length 6 m rests on a horizontal ground and leans against a smooth vertical wall. The angle made by the ladder with the horizontal is 65° . When a man of weight 700 N stands on the ladder at a distance of 4 m from the top of the ladder, the ladder is at the point of sliding. Determine the coefficient of friction between the ladder and the floor. **(08 Marks)**

8. (a) Select the correct answer: **(04 Marks)**

- (i) M.I. of an annular area with outer radius 0.8 m and inner radius 0.5 m is
(A) 0.2726 m^4 (B) 0.3726 m^4 (C) 1.222 m^4 (D) None of these
- (ii) The distance at which an area can be imagined to be placed and squeezed, so that there is no change in moment of inertia is known as
(A) Radius of gyration (B) Polar moment of inertia
(C) Moment of area (D) Second moment of area
- (iii) Moment of inertia is
(A) Resistance to change in rotational motion
(B) Acceptance to change in rotational motion
(C) Resistance to deformation
(D) None of the above
- (iv) M.I. of a rectangle about the base is
(A) $\frac{bd^3}{6}$ (B) $\frac{bd^3}{3}$ (C) $\frac{bd^3}{12}$ (D) $\frac{db^3}{12}$

(b) State and prove parallel axis theorem. **(06 Marks)**

(c) Determine M.I. about horizontal centroidal axis for the shaded area shown in Figure Q.8(c). Also find radius of gyration about the same axis. **(10 Marks)**

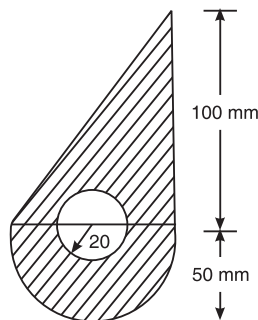

Figure Q.8(c)

First and Second Semester B.E. Degree Examination, January 2011

**ELEMENTS OF CIVIL ENGINEERING AND
ENGINEERING MECHANICS**

Time: 3 hrs.

Max. Marks: 100

- Note:**
1. Answer any FIVE full questions, choosing at least two from each part.
 2. Answer all objective type questions only on OMR sheet page 5 of the answer booklet.
 3. Answer to objective type questions on sheets other than OMR will not be valued.

PART-A

1. (a) Choose the correct answer: **(04 Marks)**
- (i) Geotechnical engineering involves the study of
(A) Water (B) Soil (C) Air (D) All of these
 - (ii) Shoulders are the components of
(A) Roads (B) Bridges (C) Buildings (D) Dams
 - (iii) A bridge constructed at some angle to the river flow is
(A) Skew bridge (B) Square bridge
(C) Steel bridge (D) Lift bridge
 - (iv) A bascule bridge is a
(A) Floating bridge (B) Arch bridge
(C) Suspension bridge (D) Movable bridge
- (b) Explain the types of roads as per the Nagpur-road plan. **(06 Marks)**
- (c) Draw a neat cross-section of the gravity dam and mark important features on it. **(04 Marks)**
- (d) Explain the following bridges, with neat sketches: **(06 Marks)**
- (i) Suspension bridge
 - (ii) Arch bridge
2. (a) Choose the correct answer: **(04 Marks)**
- (i) Effect of a force on a body depends in
(A) Magnitude (B) Direction
(C) Position or line of action (D) All of these
 - (ii) When trying to turn a key into a lock, following is applied
(A) Coplanar forces (B) Moment
(C) Lever (D) Couple
 - (iii) A single force and a couple acting in the same plane upon a rigid body
(A) Balance each other (B) Cannot balance each other
(C) Produce moment of a couple (D) One equivalent

- (iv) Moment of a force
- (A) Occurs about a point
 - (B) Measures the capacity to do useful work
 - (C) Occurs when bodies are in motion
 - (D) Measures the ability to produce turning about axes
- (b) State the law of transmissibility of force. **(02 Marks)**
- (c) Differentiate between the resultant and the equilibrant. **(04 Marks)**
- (d) Determine the angle α for which the moment of the 500 N force shown in Figure Q.2(d), is maximum about 'O'. Also, find the maximum moment. **(10 Marks)**

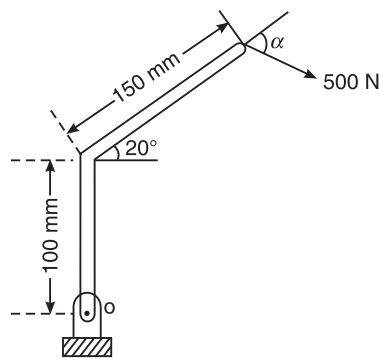

Figure Q.2(d)

3. (a) Choose the correct answer: **(04 Marks)**
- (i) Two forces each equal to $P/2$ act at right angles. Their effect may be neutralized by the third force, acting along their bisector in the opposite direction, with a magnitude of
 - (A) P
 - (B) $\sqrt{2}P$
 - (C) $-P/2$
 - (D) $P/\sqrt{2}$
 - (ii) In a coplanar concurrent forces system, if $\Sigma V = 0$, then the resultant is
 - (A) Horizontal
 - (B) Vertical
 - (C) Moment
 - (D) None of these
 - (iii) The Varignon's theorem is not applicable for the forces, which are
 - (A) Coplanar, non-concurrent
 - (B) Non-coplanar, non-concurrent
 - (C) Concurrent
 - (D) Parallel
 - (iv) The magnitude of the resultant of two forces of magnitudes P and $\sqrt{2}P$ is " P ". Then the angle between the two forces is
 - (A) 135°
 - (B) 90°
 - (C) 45°
 - (D) 30°
- (b) The sum of the two concurrent forces P and Q is 500 N and their resultant is 400 N. If the resultant is perpendicular to " P ", find P , Q and the angle between P and Q . **(06 Marks)**
- (c) The forces acting on 1 m length of a dam are shown in Figure Q.3(c). Determine the resultant force acting on the dam. Calculate the point of intersection of the resultant with the base. **(10 Marks)**

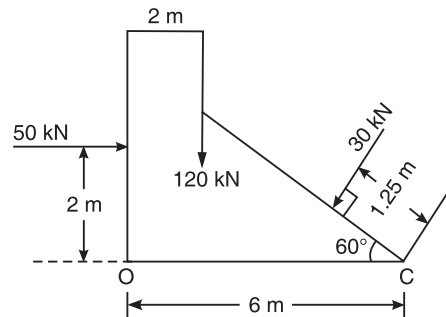

Figure Q.3(c)

4. (a) Choose the correct answer: **(04 Marks)**
- (i) The centre of gravity of a plane lamina will not be its geometrical centre if it is a

| | |
|---------------------------|--------------------------|
| (A) Square | (B) Rectangle |
| (C) Right angled triangle | (D) Equilateral triangle |
 - (ii) The centroid of an equilateral triangle of side a is _____ from any of the three sides,

| | | | |
|---------------------------|---------------------------|---------------------------|---------------------------|
| (A) $\frac{a\sqrt{3}}{2}$ | (B) $\frac{a\sqrt{2}}{3}$ | (C) $\frac{a}{2\sqrt{3}}$ | (D) $\frac{a}{3\sqrt{2}}$ |
|---------------------------|---------------------------|---------------------------|---------------------------|
 - (iii) The centroid of a semicircle of radius (r), with respect to its base is

| | | | |
|-----------------------|-----------------------|-----------------------|----------------------|
| (A) $\frac{3r}{3\pi}$ | (B) $\frac{3r}{8\pi}$ | (C) $\frac{4r}{3\pi}$ | (D) $\frac{4r}{\pi}$ |
|-----------------------|-----------------------|-----------------------|----------------------|
 - (iv) Moment of the total area about its centroidal axis is

| | |
|--------------------|--------------------------|
| (A) Twice the area | (B) Three times the area |
| (C) Zero | (D) None of these |
- (b) Determine the centroid of a sector of radius r by the method of integration. **(06 Marks)**
- (c) Find the centroid of the shaded area shown in Figure Q.4(c), obtained by cutting a semicircle of diameter 100 mm from the quadrant of a circle of radius 100 mm. **(10 Marks)**

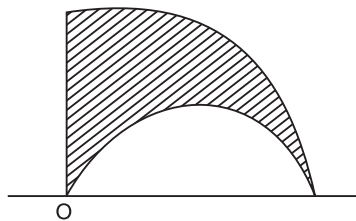

Figure Q.4(c)

PART B

5. (a) Choose the correct answer:

(04 Marks)

- (i) A free body diagram is a diagram
 (A) Drawn by free hand
 (B) Of a body suspended freely in air
 (C) Of a body in vacuum, free from any influence from the surroundings
 (D) Drawn by detaching the body from its attachments with surroundings and replacing the attachments with force vector.
- (ii) A particle acted upon by the two forces of equal magnitude is in equilibrium. The angle between the force is
 (A) 0° (B) 90° (C) 180° (D) 45°
- (iii) If a body is in equilibrium, it is concluded that
 (A) No force is acting on the body
 (B) The resultant of all the forces acting on it is zero
 (C) The moment of the forces about any point is zero
 (D) Both (B) and (C)
- (iv) Three forces of magnitudes $F_1 = 100\text{ N}$, $F_2 = 100\text{ N}$ and $F_3 = 100\sqrt{3}\text{ N}$ act on a particle in a plane. The particle remains in equilibrium, only if the angle between F_1 and F_2 is
 (A) 30° (B) 45° (C) 60° (D) 90°

- (b) A 3 kN crate is to be supported by a rope and pulley arrangements shown in Figure Q.5(b). Determine the magnitude and direction of the force 'F', which should be exerted at the free end of the rope.

(06 Marks)

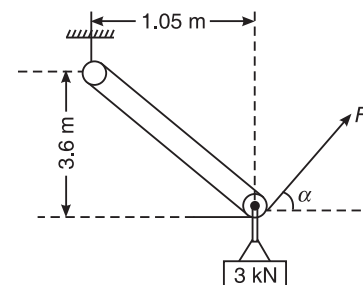

Figure Q.5(b)

- (c) Two rollers of weights "P" and "Q" are connected by a flexible string DE and rest on two mutually perpendicular planes AB and BC as shown in Figure Q.5(c). Find the tension (T) in the string and angle " ϕ ", that it makes, with the horizontal, when system is in equilibrium. Given $P = 600\text{ N}$, $Q = 1000\text{ N}$, $\alpha = 30^\circ$. Assume that the string is inextensible and passes freely through the slots in the smooth inclined planes AB and BC.

(10 Marks)

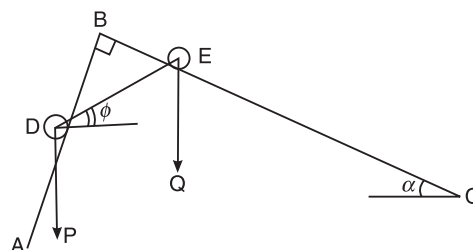

Figure Q.5(c)

6. (a) Choose the correct answer: **(04 Marks)**

- (i) Fixed beams have
 - (A) One end fixed and other end simply supported
 - (B) Both ends fixed
 - (C) Both ends roller supported
 - (D) One end fixed and other end free
- (ii) GVL stands for
 - (A) General varying load
 - (B) Gradually vertical load
 - (C) Gradually varying load
 - (D) General variable load
- (iii) A truss is perfect when
 - (A) $m = 2J - 3$
 - (B) $2J = m + 3$
 - (C) $m = 3J - 2$
 - (D) $2J = m - 3$
- (iv) The minimum number of members to form a perfect truss is
 - (A) 1
 - (B) 2
 - (C) 3
 - (D) 4

(b) Determine the reactions at the supports A and B, for the beam shown in Figure Q.6(b) **(06 Marks)**

(c) Find the support reactions and member forces for the pin-jointed plane truss shown in Figure Q.6(c), by method of joints. **(10 Marks)**

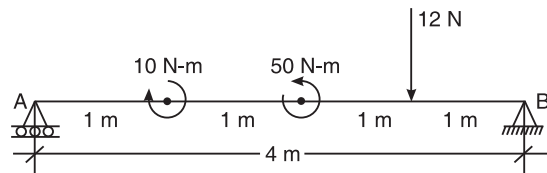

Figure Q.6(b)

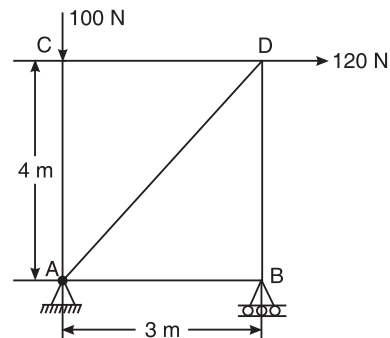

Figure Q.6(c)

7. (a) Choose the correct answer: **(04 Marks)**

- (i) The angle which an inclined surface makes with the horizontal, when a body placed on it is on the point of moving down, is known as,
 - (A) Angle of friction
 - (B) Angle of limiting friction
 - (C) Angle of inclination
 - (D) Angle of repose
- (ii) If the angle of friction is zero, a body will experience
 - (A) Infinite friction
 - (B) Zero friction
 - (C) The force of friction normal to the plane
 - (D) The force of friction in the direction of motion

- (iii) The coefficient of friction depends on
 (A) Area of contact (B) Shape of the surface
 (C) Strength of the surface (D) All of these
- (iv) The tangent of the angle of friction is of
 (A) Angle of repose (B) Coefficient of friction
 (C) Cone of friction (D) Limiting friction
- (b) (i) (A) Angle of friction (ϕ), (B) Coefficient of friction (μ). **(02 Marks)**
 (ii) Determine the value of " θ " for impending motion of the blocks. Take coefficient of friction (μ) for all contact surfaces as 0.25 [Refer Figure Q.7(b) (ii)]. **(6 Marks)**
- (c) The ladder shown in Figure Q.7(c), is 4 m long and is supported by a horizontal floor and vertical wall. The coefficient of friction at the wall is 0.25 and at the floor is 0.50. The weight of the ladder is 200 N, considered concentrated at "G". The ladder supports a vertical load of 1000 N at "C". Determine the reactions at A and B and compute the least value of " α " at which, the ladder may be placed without slipping. **(08 Marks)**

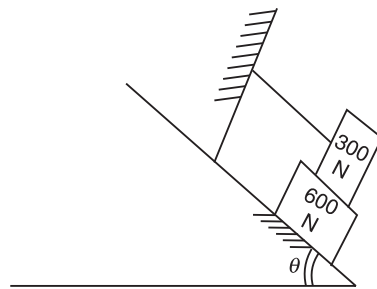

Figure Q.7(c)

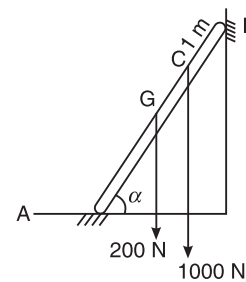

Figure Q.7(b) (ii)

8. (a) Choose the correct answer: **(04 Marks)**
- (i) The ratio of the moment of inertia for triangle ($b \times h$) coinciding with its base to a centroidal axis parallel to the base is
 (A) $\frac{bh^3}{2}$ (B) $\frac{bh^3}{4}$ (C) $\frac{bh^3}{8}$ (D) $\frac{bh^3}{12}$
- (ii) The radius of gyration of a circular area of radius " r " is
 (A) $\frac{r}{2}$ (B) $\frac{r}{4}$ (C) $\frac{2r}{4}$ (D) $\frac{3r}{4}$
- (iii) The unit of moment of inertia of an area is
 (A) kg.m (B) kg.m² (C) kg.m⁴ (D) m⁴
- (iv) If I_G is the moment of inertia of a rectangle about its centroidal axis and I_{AB} is the moment of inertia about its base then
 (A) $I_G > I_{AB}$ (B) $I_G < I_{AB}$ (C) $I_G = I_{AB}$ (D) None of these

422 EXAMINATION PAPERS OF VTU

- (b) Derive the expression for the moment of inertia of a semicircular lamina of radius (r) about its centroidal axis parallel to the diameter. **(04 Marks)**
- (c) Determine the radius of gyration about the centroidal axes for the lamina shown in Figure Q.8(c). All dimensions are in mm. **(12 Marks)**

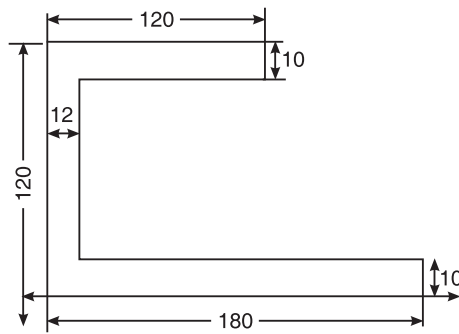

Figure Q.8(c)

First and Second Semester B.E. Degree Examination, December 2010

**ELEMENTS OF CIVIL ENGINEERING AND
ENGINEERING MECHANICS**

Time: 3 hrs.

Max. Marks: 100

- Note:**
1. Answer any FIVE full questions, choosing at least two from each part.
 2. Answer all objective type questions only on OMR sheet page 5 of the answer booklet.
 3. Answer to objective type questions on sheets other than OMR will not be valued.

PART-A

1. (a) Select the correct answer:
- (i) Surveying deals with **(04 Marks)**
 - (A) Sub soil exploration
 - (B) Estimation of quality and quantity of surface and subsurface water
 - (C) Determination of correct distance between objects or stations
 - (D) Design of super structure and substructures
 - (ii) Infrastructure development focuses on providing
 - (A) Transportation facilities
 - (B) Water system and drainage facilities
 - (C) Power supply and communication facilities
 - (D) All of the above
 - (iii) Dams are
 - (A) Constructed to cross a channel or flowing water
 - (B) Barrier or obstacle constructed across a water stream
 - (C) Constructed across a tunnel
 - (D) None of the above
 - (iv) The roads connecting important towns, areas of production and market places, connecting with each other or with the main highway of a district are
 - (A) Major district roads
 - (B) Arterial roads
 - (C) Expressways
 - (D) None of these
- (b) Briefly explain scope of the following in civil engineering: **(09 Marks)**
(i) Surveying (ii) Geotechnical engineering (iii) Hydraulics
- (c) What are the different types of roads? Explain. Also, sketch a typical cross-section of a road. **(07 Marks)**
2. (a) Select the correct answer:
- (i) If a number of forces are acting simultaneously on a particle, then each of them will produce the same effect, which it would have done while acting alone. This is known as: **(04 Marks)**
 - (A) The principle of physical independence of forces

424 EXAMINATION PAPERS OF VTU

- (B) The principle of transmissibility of forces
 (C) The principle of resolution of forces
 (D) None of the above
- (ii) In order to determine the effects of forces acting on a body, we must know
 (A) Its magnitude and point at which it acts on the body
 (B) Direction of the line along which it acts
 (C) Their nature (whether push or pull)
 (D) All of the above
- (iii) Free body diagram of a body shows
 (A) A body isolated from all external forces
 (B) A body isolated from all its surroundings and all external forces acting on it
 (C) A body shown separately from its surroundings and all external and internal forces acting on it
 (D) None of the above
- (iv) The effect of a couple is unchanged if
 (A) The couple is rotated through any angle
 (B) The couple is shifted to any other position
 (C) The couple is replaced by another pair of forces, whose rotational affects are the same
 (D) All of the above
- (b) Classify the systems of forces and their characteristics with an illustration. **(10 Marks)**
- (c) Reduce the system shown in Figure Q.2(c), to (i) single force (ii) single force and couple at A (iii) single force and couple at B **(06 Marks)**

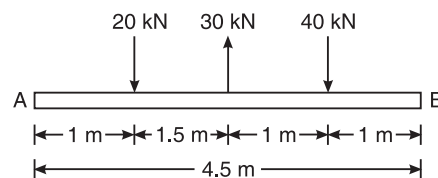

Figure Q.2(c)

3. (a) Select the correct answer:
- (i) If a force F makes an angle θ with x -axis, the components of force with respect to x -axis and y -axis, respectively, are **(04 Marks)**
 (A) $F \cos \theta, F \sin \theta$ (B) $F \sin \theta, F \cos \theta$
 (C) $F \tan \theta, F \sin \theta$ (D) $F \sin \theta, F \sec \theta$
- (ii) Direction of the resultant force can be determined by
 (A) $\tan \theta = \left(\frac{\Sigma V}{\Sigma H} \right)$ (B) $\tan \theta = \left(\frac{\Sigma H}{\Sigma V} \right)$
 (C) $\tan \theta = \sqrt{(\Sigma H)^2 + (\Sigma V)^2}$ (D) None of these

- (iii) Varignon's principle of moments can be stated as
- Moment of resultant force R about 'X' = Moment of force P about 'X' \times Moment of force Q about 'X'
 - Moment of resultant force R about 'X' = Moment of force P about 'X' \div Moment of force Q about 'X'
 - Moment of resultant force R about 'X' = Moment of force P about 'X' + Moment of force Q about 'X'
 - None of the above
- (iv) Moment of a force is defined as
- Linear effect of a force about a point
 - Rotational effect of a force about a point
 - Turbulent effect of a force about a point
 - All of the above
- (b) The four coplanar forces acting at a point are as shown in Figure Q.3(b). One of the forces is unknown and its magnitude is as shown by ' F '. The resultant is 500 N and is along x -axis. Determine the force ' F ' and its inclination θ with x -axis **(06 Marks)**

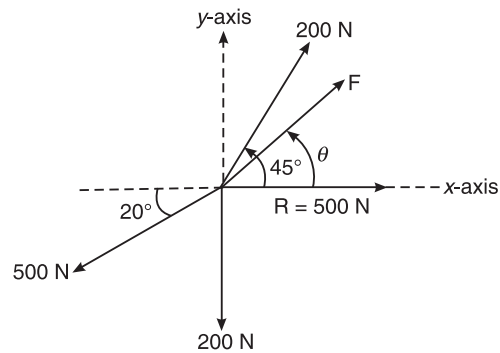

Figure Q.3(b)

- (c) Four forces act on a $700 \text{ mm} \times 375 \text{ mm}$ plate as shown in Figure Q.3(c). Find (i) the resultant of these forces (ii) locate the point where the line of action of the resultant intersects the edge AB of the plate. **(10 Marks)**

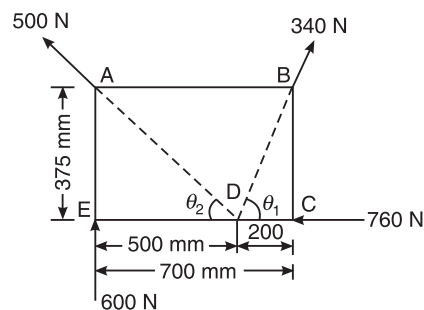

Figure Q.3(c)

426 EXAMINATION PAPERS OF VTU

4. (a) Select the correct answer

(i) The centre of gravity is a point (04 Marks)

- (A) At which the whole area of the plane figure is concentrated
 (B) At which the whole volume of the body is concentrated
 (C) At which the whole weight of the body acts
 (D) All of the above

(ii) The centroid in x -direction in general is

- (A) $\frac{\Sigma a}{\Sigma ax}$ (B) $\frac{\Sigma ax}{\Sigma a}$
 (C) $\Sigma ax \times \Sigma a$ (D) $\Sigma ax + \Sigma a$

(iii) The centroid of a right angled triangle, with base as x -axis and opposite side as y -axis is

- (A) 1/3rd of h , 1/3rd of b (B) 2/3rd of b , 2/3rd of h
 (C) 1/3rd of b , 2/3rd of h (D) 2/3rd of b , 1/3rd of h

(iv) The centroid of a circle with its origin as axes is given by

- (A) r, r (B) 0, 0 (C) 0, $4r/3\pi$ (D) $4r/3\pi, 0$

(b) Locate the centroid of a triangle, from the first principles (06 Marks)(c) Determine the location of the centroid of the shaded portion of the lamina, shown in Figure Q.4(c), with respect to the origin 'O'. (10 Marks)

Figure Q.4(c)

PART B

5. (a) Select the correct answer:

(i) An equilibrant is a force (04 Marks)

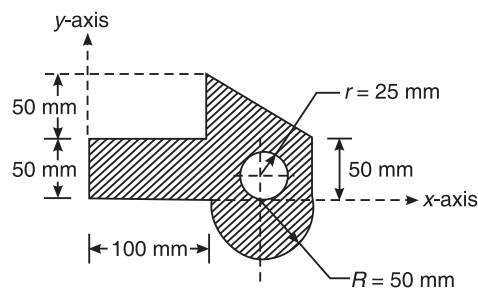
- (A) Unequal in magnitude, opposite in direction and collinear with the resultant
 (B) Equal in magnitude, opposite in direction and non-collinear with the resultant
 (C) Equal in magnitude, opposite in direction and collinear with the resultant
 (D) Unequal in magnitude, opposite in direction and non-collinear with the resultant

(ii) Equilibrium equations are

- (A) $\Sigma H = 0$ (B) $\Sigma V = 0$ (C) $\Sigma M = 0$ (D) All of these

- (iii) Lami's theorem is applicable for
- Coplanar forces
 - Concurrent forces
 - Coplanar and concurrent forces
 - Any types of forces
- (iv) For a smooth spherical surface, reaction acts
- Inclined to the plane of contact
 - Perpendicular to the plane of contact
 - Horizontal to the plane of contact
 - All of the above
- (b) Determine the tension in cables AB and AC required to hold a 50 kg crate, shown in Figure Q.5(b). Take $g = 9.81 \text{ m}^2/\text{s}$. **(06 Marks)**
- (c) A system of connected flexible cables shown in Figure Q.5(c), is supporting two vertical forces 200 N and 250 N at points B and D. Determine the forces in various segments of the cable. **(10 Marks)**

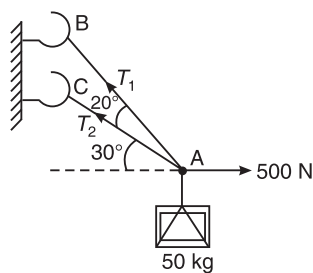

Figure Q.5(b)

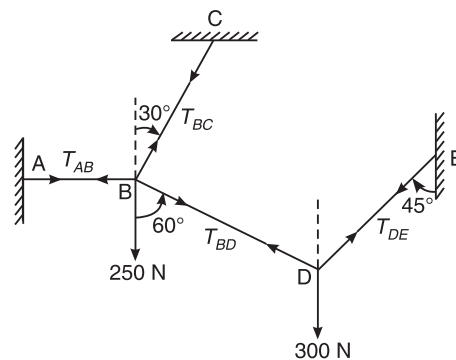

Figure Q.5(c)

6. (a) Select the correct answer:
- When the reaction at a support consists of a moment, a vertical force and a horizontal force, then that support is called as **(04 Marks)**
 - Hinged support
 - Roller support
 - Fixed support
 - Simple support
 - A single span beam is statically determinate when
 - Both the ends are fixed
 - One end is fixed, other end is simply supported
 - One end is hinged and other is roller supported
 - Both ends are hinged
 - A beam AB is fixed at one end, free at the other, and loaded by a concentrated load W at the free end. Then developed reaction R_A , will be equal to
 - $W/3 \text{ kN}$
 - $W \text{ kN}$
 - $W/2 \text{ kN}$
 - $2W/3 \text{ kN}$

428 EXAMINATION PAPERS OF VTU

- (iv) If W kN/m uniformly distributed load is acting on a simply supported beam AB , then reactions R_A and R_B will be equal to
- (A) $W/3$ kN, $2W/3$ kN (B) $W/4$ kN, $3W/4$ kN
 (C) $2W/3$ kN, $W/3$ kN (D) $W/2$ kN, $W/2$ kN
- (b) What are the types of loads and supports a beam may have? **(06 Marks)**
- (c) A beam $ABCDEF$ is hinged at A , supported on rollers at E and carries loads as shown in Figure Q.6(c). Determine the reactions at the supports. **(10 Marks)**

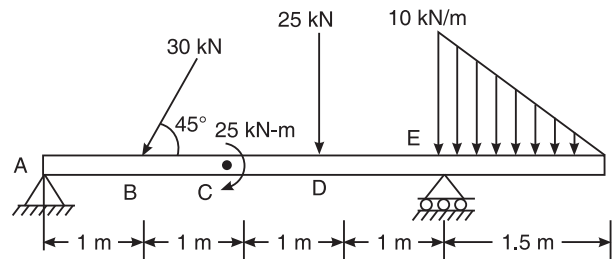

Figure Q.6(c)

7. (a) Select the correct answer:
- (i) Static friction is defined as **(04 Marks)**
- (A) The friction acting on a body, when the contact surfaces are lubricated
 (B) The friction acting on a body, which is actually in motion
 (C) The friction acting on a body, which is at rest
 (D) All of the above
- (ii) If a body is placed on an inclined plane, then the angle at which the body is just at the point or verge of sliding down, is called
- (A) Angle of friction (B) Cone of friction
 (C) Coefficient of friction (D) Angle of repose
- (iii) The magnitude of the force of friction between two bodies, one lying above the other, depends upon the roughness of the
- (A) Upper body (B) Lower body
 (C) Both the bodies (D) The body having more roughness
- (iv) A uniform ladder of weight W and length ' L ' rests on horizontal ground and leans on a rough vertical wall with angle ' θ '. When a man stands on the ladder, the ladder slips towards
- (A) Left at the ground and towards up at the wall
 (B) Left at the ground and towards down at the wall
 (C) Right at the ground and towards up at the wall
 (D) Right at the ground and towards down at the wall
- (b) Explain:
- (i) Types of friction (ii) Laws of friction **(06 Marks)**

- (c) A 4 m ladder weighing 200 N is placed against a vertical wall as shown in Figure Q.7(c). As a man weighing 800 N, reaches a point 2.7 m from A, the ladder is about to slip. Assuming that the coefficient of friction between the ladder and the wall is 0.2, determine the coefficient of friction between the ladder and the floor. **(10 Marks)**

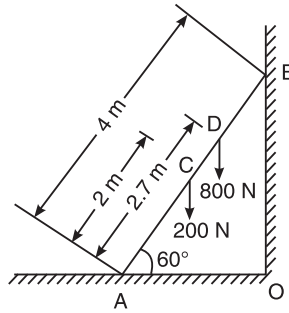

Figure Q.7(c)

8. (a) Select the correct answer:

(i) Radius of gyration may be defined mathematically as **(04 Marks)**

(A) $\sqrt{\frac{A}{I}}$ (B) $\sqrt{\frac{I}{A}}$ (C) $\frac{I}{A}$ (D) $\frac{A}{I}$

(ii) Moment of inertia of a plane area about 1-1 axis parallel to centroidal axis is equal to

(A) $\frac{I_{xx}}{A\bar{y}^2}$ (B) $I_{xx} \times A\bar{y}^2$ (C) $I_{xx} - A\bar{y}^2$ (D) $I_{xx} + A\bar{y}^2$

(iii) The moment of inertia of triangle about the base is given by

(A) $\frac{\pi}{64}(D^4 - d^4)$ (B) $\frac{bh^3}{36}$ (C) $\frac{bh^3}{12}$ (D) $\frac{rd^3}{256}$

(iv) Moment of inertia of a semicircle about centroidal axis is given by

(A) $0.055 r^4$ (B) $0.11 r^4$ (C) $0.11 d^4$ (D) $\frac{\pi d^4}{64}$

(b) State and prove the parallel axis theorem. **(04 Marks)**

(c) Determine the moment of inertia and radii of gyration of the area shown in Figure Q.8(c), about the base AB and the centroidal axis parallel to AB. **(12 Marks)**

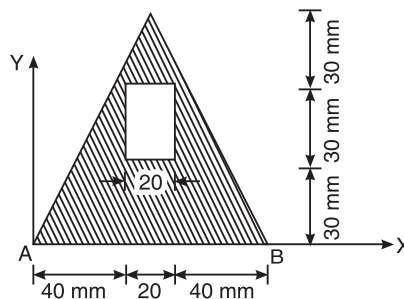

Figure Q.8(c)

First and Second Semester B.E. Degree Examination, May/June 2010

**ELEMENTS OF CIVIL ENGINEERING AND
ENGINEERING MECHANICS**

Time: 3 hrs.

Max. Marks: 100

- Note:** 1. Answer any FIVE full questions, choosing at least two from each part.
2. Answer all objective type questions only in OMR sheet page 5 of the Answer Booklet.
3. Answer to objective type questions on sheets other than OMR will not be valued.

PART-A

1. (a) (i) Studying the properties of soil in assessing safe bearing capacity is called as
(A) Transportation engineering (B) Building materials
(C) Estimation (D) Geotechnical engineering
- (ii) Building tanks and dams and carrying stored water to field is known as
(A) Structural engineering
(B) Environmental engineering
(C) Water resources and irrigation engineering
(D) Construction technology
- (iii) Kerbs are the components of
(A) Roads (B) Bridges (C) Building (D) Dam
- (iv) Reinforced cement concrete (RCC) comes under
(A) Architecture and town planning
(B) Hydraulics
(C) Surveying
(D) Structural engineering **(04 Marks)**
- (b) Briefly explain the role of civil engineers in the infrastructure development. **(06 Marks)**
- (c) With the help of the neat sketches, briefly explain the cross sections of road and dam. **(10 Marks)**
2. (a) (i) To define a force completely, the following characteristics should be specified. **(04 Marks)**
(A) Magnitude and direction (B) Point of application
(C) Line of action (D) All of these
- (ii) The net force that results from a number of individual forces acting on an object is the vector sum of the individual forces. This is termed as the
(A) Principle of superposition
(B) Principle of transmissibility
(C) Moment of forces
(D) Principle of physical independence

- (iii) Forces co-exist on a plane and all the forces act-helter-skelter over the body. These are
- Coplanar non-concurrent forces
 - Coplanar concurrent forces
 - Coplanar parallel forces
 - Non-coplanar non-concurrent forces
- (iv) The principle of transmissibility states that, when a force acts upon a body, its effect is
- Maximum, if it acts at the centre of gravity of the body
 - Different at different points on its line of action
 - Same at every point on its line of action
 - Minimum if it acts at the CG of the body
- (b) What is the moment of a force: What are the various moments encountered in practice? Explain them. **(05 Marks)**
- (c) Determine the equivalent system of force and couple at 'A' for the system of loading as shown in Figure Q.2(c) on next page. **(11 Marks)**

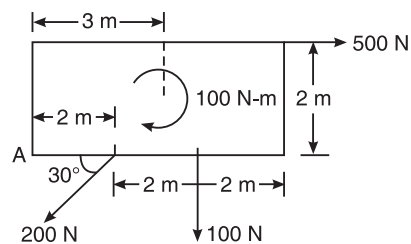

Figure Q.2(c)

3. (a) (i) The simplest resultant of a parallel force system is always **(04 Marks)**
- A wrench
 - A force
 - A moment
 - A force and a moment
- (ii) The purpose of replacing a number of forces acting on a body simultaneously is
- To find resolution
 - To find transmission
 - To find resultant
 - To find moment of forces
- (iii) If two forces act at an angle of 120° , the greater force is 50 N and their resultant is perpendicular to the smaller force, the smaller force is
- 20 N
 - 25 N
 - 30 N
 - 43.33 N
- (iv) If two forces P and Q ($P > Q$) act on the same straight line but in opposite direction, their resultant is
- $P + Q$
 - P/Q
 - $Q - P$
 - $P - Q$
- (b) State and prove Varignon's theorem of moments. **(06 Marks)**

432 EXAMINATION PAPERS OF VTU

- (c) The system of forces acting on a triangular plate is as shown in Figure Q.3(c). Determine the magnitude, direction of the resultant and its position with respect to 'O'. (10 Marks)

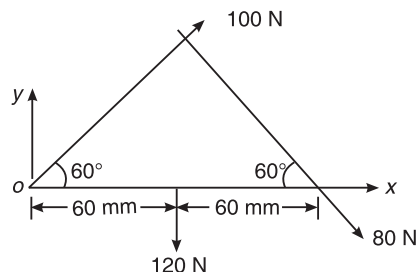

Figure Q.3(c)

4. (a) (i) The centroid of a lamina (04 Marks)
- (A) Must be a point on the lamina
 - (B) Is a point which can be made to lie on or outside the lamina by changing the co-ordinates system
 - (C) Is a fixed point in space regardless of the orientation of the lamina
 - (D) Is a unique point fixed with respect to the lamina
- (ii) The centroid of a triangle of height 'h' is located at a distance from its apex, which is
- (A) $h/2$
 - (B) $h/3$
 - (C) $2h/3$
 - (D) h
- (iii) Centroid conveys some clue about
- (A) The orientation of a surface
 - (B) Centre of a body
 - (C) Shape and disposition of the area
 - (D) Area of cross-section
- (iv) An axis over which one half the plane figure is just the mirror of the other half is
- (A) Reference axis
 - (B) Axis of symmetry
 - (C) Unsymmetrical axis
 - (D) None of these
- (b) Determine the centroid of a quadrant circle by the method of integration. (06 Marks)
- (c) For a shaded area shown in Figure Q.4(c), find a so that centroid is at O. (10 Marks)

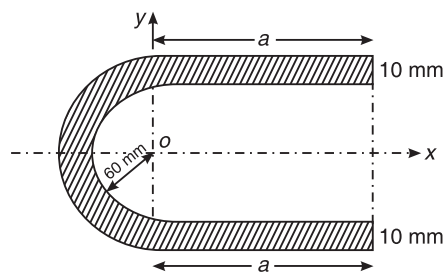
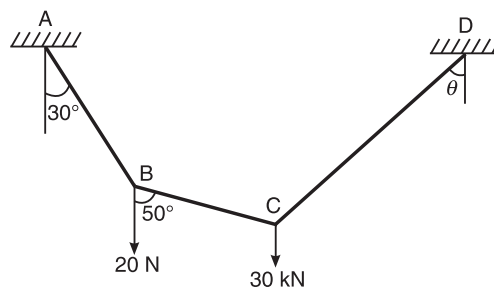

Figure Q.4(c)

PART B

5. (a) (i) A rigid body is in equilibrium under the action of three forces. It implies that the forces must be such that the **(04 Marks)**
- (A) Resultant is zero (B) Equilibrant is zero
(C) Both (A) and (B) (D) None of these
- (ii) Lami's theorem
- (A) Relates the forces with the sines of angles
(B) Relates the action of three concurrent forces and sines of angles
(C) May be applied to consider relationship between forces
(D) May be applied for a body which may or may not be in equilibrium
- (iii) If sum of all the forces acting on a body is zero, it may be concluded that the body
- (A) Must be in equilibrium
(B) Cannot be in equilibrium
(C) May be in equilibrium provided the forces are concurrent
(D) May be in equilibrium provided the forces are parallel
- (iv) The necessary condition of equilibrium of concurrent force system is
- (A) The algebraic sum of horizontal and vertical forces must be zero
(B) The algebraic sum of moments of forces must be zero
(C) The algebraic sum of horizontal, vertical and moments of forces must be zero
(D) All of the above
- (b) Define free body diagram. Describe types of forces acting on a body. Explain them in brief. **(06 Marks)**
- (c) A wire rope is fixed at two points A and D as show in in Figure Q.5(c). Weights 20 kN and 30 kN are attached to it at B and C respectively. The weights rest with portions AB and BC inclined at 30° and 50° respectively, to the vertical as shown. Find the tension in segments AB, BC and CD of the wire. Determine the inclination of the segment CD to vertical (θ). **(10 Marks)**

**Figure Q.5(c)**

434 EXAMINATION PAPERS OF VTU

6. (a) (i) A beam is said to be determinate, if (04 Marks)
- (A) The reactions can be determined using the equations of equilibrium
 - (B) The reactions cannot be determined using the equations of equilibrium
 - (C) The reactions cannot be determined by using the force equilibrium conditions
 - (D) The reaction can be determined by using the moment equilibrium condition only
- (ii) The beam is neither permitted to move in any direction nor allowed to rotate in the case of
- (A) Hinged support
 - (B) Fixed support
 - (C) Roller support
 - (D) Simple support
- (iii) uvl stands for
- (A) Uniform vertical load
 - (B) Uniform velocity load
 - (C) Uniform vague load
 - (D) Uniformly varying load
- (iv) A thin rigid beam hinged at one end and roller-supported at its mid-point is said to be
- (A) A simply supported beam
 - (B) A overhanging beam
 - (C) A cantilever beam
 - (D) A fixed beam

(b) Differentiate between resultant and equilibrant (04 Marks)

(c) Determine the reactions at the supports for the system shown in Figure Q.6(c).

(12 Marks)

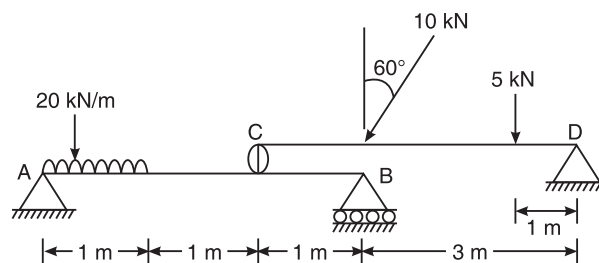

Figure Q.6(c)

7. (a) (i) The frictional force is independent of (04 Marks)
- (A) The area of contact
 - (B) The coefficient of friction
 - (C) The normal reaction
 - (D) The angle of friction
- (ii) Once a body just begins to slide, it continues to slide because
- (A) The body has inertia
 - (B) Inertia force acts on the body
 - (C) The body accelerates
 - (D) The frictional force becomes less
- (iii) The coefficient of friction between two surfaces is the constant of proportionality between the applied tangential force and the normal reaction
- (A) At the instant of application of the force
 - (B) At an instant when the body is at rest

- (C) At the instant of impending motion
 (D) At an instant after the motion takes place
- (iv) The angle of friction is angle between
 (A) The incline and the horizontal
 (B) The normal reaction and frictional force
 (C) The weight of the body and the friction force
 (D) The normal reaction and the resultant
- (b) Define coefficient of friction. Show that the coefficient of friction is tangent of the angle of friction. **(04 Marks)**
- (c) In the Figure Q.7(c), determine the minimum value of P, just required to lift 3000 N up. The angle of friction between block and the wall is 15° and for other surfaces it is 18° . **(12 Marks)**

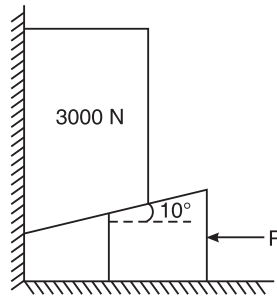

Figure Q.7(c)

8. (a) (i) The moment of inertial of a rectangular lamina of sides b and h about its neutral axis parallel to the sides b is given by **(04 Marks)**
- (A) $\frac{bh^3}{12}$ (B) $\frac{bh^3}{36}$ (C) $\frac{hb^3}{12}$ (D) $\frac{hb^3}{36}$
- (ii) The unit of radius of gyration of an area is
 (A) N/m (B) N/m^2
 (C) m^3 (D) m
- (iii) The value of moment of inertia depends upon
 (A) Type of material (B) Weight of material
 (C) Density of material (D) Cross-sectional dimensions
- (iv) Moment of inertia is a
 (A) First order term (B) Second order term
 (C) Fourth order term (D) Third order term
- (b) State the parallel axis theorem. **(02 Marks)**
- (c) Explain the polar moment of inertia and the radius of gyration. **(04 Marks)**

436 EXAMINATION PAPERS OF VTU

- (d) Find the moment of inertia of the area shown in Figure Q.8(d) about its centroidal axis parallel to the coordinate axis. **(10 Marks)**

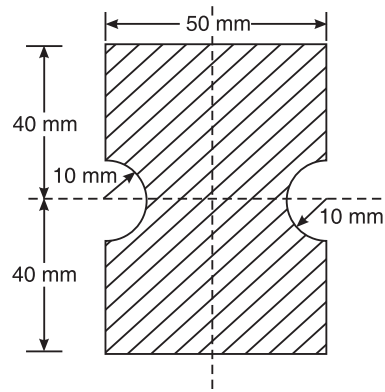

Figure Q.8(d)

First and Second Semester B.E. Degree Examination, Dec. 2009/Jan. 2010

**ELEMENTS OF CIVIL ENGINEERING AND
ENGINEERING MECHANICS**

Time: 3 hrs.

Max. Marks: 100

- Note:** 1. Answer any FIVE full questions, choosing at least two from each part.
2. Answer all objective type questions only in OMR sheet page 5 of the Answer Booklet.
3. Answer to objective type questions on sheets other than OMR will not be valued.

PART-A

1. (a) (i) The part of civil engineering which deals with design of slabs, beams, columns, footings etc. is called **(04 Marks)**
(A) Transportation engineering (B) Structural engineering
(C) Geotechnical engineering (D) Water supply engineering
- (ii) The science of map making is known as:
(A) Estimation (B) Surveying
(C) Town planning (D) Construction technology
- (iii) The structure which provides passage over the obstacles like valley, river without closing the way underneath is:
(A) Dam (B) Bridge (C) Harbour (D) Airport
- (iv) Pick up a structure in which an inspection gallery is formed:
(A) Gravity dam (B) Bridge (C) Harbour (D) Airport
- (b) Explain different types of dams, with neat sketches. **(08 Marks)**
- (c) Explain briefly the scope of civil engineering in:
(i) Structural engineering (ii) Transportation engineering **(08 Marks)**
2. (a) (i) Principle of transmissibility of forces states that, when a force acts upon a body, its effect is **(04 Marks)**
(A) Minimum if it acts at the C.G. of the body
(B) Maximum if it acts at the C.G. of the body
(C) Same at every point on its line of action
(D) Different at different points on its line of action
- (ii) Two parallel forces equal in magnitude and opposite in direction and separated by a definite distance are said to form
(A) Moment (B) Couple
(C) Resultant (D) Equilibrant
- (iii) Effect of a force on a body depends upon its
(A) Direction (B) Position
(C) Magnitude (D) All of these

438 EXAMINATION PAPERS OF VTU

- (iv) The forces which pass through a single point and lie in the same plane are
 (A) Collinear forces (B) Coplanar non-concurrent forces
 (C) Coplanar concurrent forces (D) None of these
- (b) Explain briefly: (i) force and its characteristics (ii) couple and its characteristics
(06 Marks)
- (c) A force $F_1 = 1200$ N is acting vertically on an incline [Refer Figure Q.2(c)]. Find its components along X and Y axes.
(05 Marks)

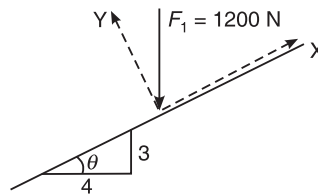

Figure Q.2(c)

- (d) Find the moment of 500 N force about the points A, B, C, D as in Figure Q.2(d).
(05 Marks)

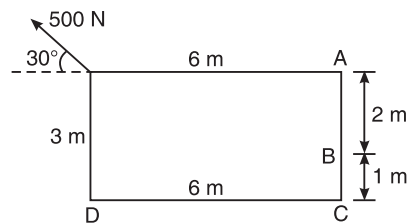

Figure Q.2(d)

3. (a) (i) The single force which will have the same effect as the system of forces is
(04 Marks)
 (A) Couple (B) Resultant (C) Moment (D) Force
- (ii) If two forces M and N ($M > N$) act on the same straight line but in opposite direction, their resultant is:
 (A) $(M + N)$ (B) M/N (C) $(N - M)$ (D) $(M - N)$
- (iii) If the resultant of coplanar concurrent force system acts along horizontal X-axis, then
 (A) $\sum F_x = 0$ (B) $\sum F_x = R$ (C) $\sum F_y = R$ (D) None of these
- (iv) The resultant of force system shown in Figure Q.3(a) (iv)
 (A) 65 N (B) 40 N (C) 76.32 N (D) 32.76 N
- (b) Three forces acting on a hook are as shown in Figure Q.3(b). Find the direction of the fourth force of magnitude 100 N such that the hook is pulled in X-direction only. Find the resultant force.
(08 Marks)

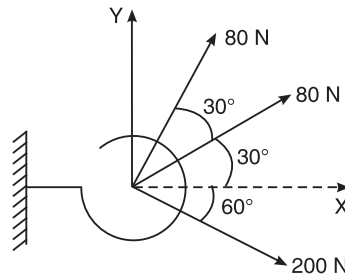

Figure Q.3(b)

- (c) Find magnitude and direction of the resultant force; also find X and Y intercepts of resultant force with respect to point A [Refer Figure Q.3(c)]. **(08 Marks)**

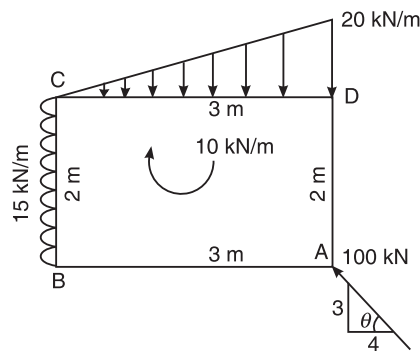

Figure Q.3(c)

4. (a) (i) The centroid of a triangle of height “ h ” is located at a— distance from its base **(04 Marks)**
- (A) $h/2$ (B) $2h/3$ (C) $h/3$ (D) h
- (ii) An axis over which one half of the plane figure is just mirror image of the other half, is
- (A) Axis of symmetry (B) Unsymmetrical axis
(C) Bottom most axis (D) None of these
- (iii) If the given plane figure is symmetrical about vertical Y–Y axis, the centroid lies on
- (A) X axis (B) Vertical Y–Y axis
(C) Bottom (D) Top
- (iv) The centroid of a plane lamina will not be at its geometrical centre if it is a
- (A) Rectangle (B) Circle
(C) Right angled triangle (D) Square
- (b) Find C.G. of the shaded area, Figure Q.4(b) with respect to given X and Y axes. **(06 Marks)**

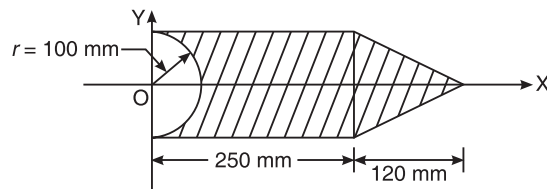

Figure Q.4(b)

- (c) Find C.G. of the shaded area, Figure Q.4(c) with respect to given X and Y axes. **(10 Marks)**

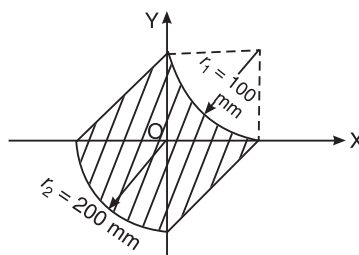

Figure Q.4(c)

PART B

5. (a) (i) The force which is equal and opposite to resultant is **(04 Marks)**
(A) Force (B) Equilibrant (C) Moment (D) None of these
- (ii) The Lami's equation can be applied when number of unknown forces are
(A) Two (B) Three (C) Five (D) None of these
- (iii) The necessary condition of equilibrium of co-planar concurrent force system is
(A) $\sum F_y = \sum F_x$ (B) $\sum F_x = 0, \sum F_y = 0$
(C) $\sum M = 0$ (D) $\sum F_x - \sum F_y = 1$
- (iv) A system that possesses a resultant
(A) Will be in equilibrium (B) Will be under rest
(C) Will not be in equilibrium (D) None of these
- (b) Find the tension in the string and reaction at the contact surface for the cylinder of $Wt = 1000\text{ N}$ placed as shown in Figure Q.5(b). Solve by Lami's theorem. **(06 Marks)**

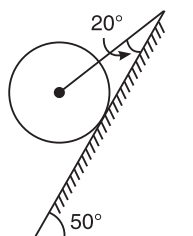

Figure Q.5(b)

- (c) In the Figure Q.5(c) shown, the portion BC is horizontal. Pulley is frictionless. Find tension in each part of the string and also find W_1 and W_2 using equations of equilibrium only. **(10 Marks)**

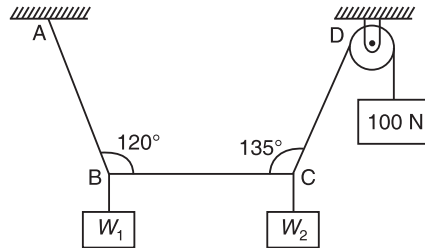

Figure Q.5(c)

6. (a) (i) The number of reaction components at an hinged end of a beam are **(04 Marks)**
(A) 0 (B) 2 (C) 3 (D) 1
- (ii) UDL stands for
(A) Uniform dead load (B) Uniform door load
(C) Uniformly distributed load (D) None of these
- (iii) A cantilever beam is one in which
(A) Both ends are fixed (B) Both ends are hinged
(C) One end is fixed and other is free (D) One end is fixed and other is simply supported
- (iv) At the fixed end of cantilever, number of unknown reaction components are
(A) 1 (B) 2 (C) 3 (D) 4
- (b) Find reactions for a cantilever beam, shown in Figure Q.6(b) **(04 Marks)**

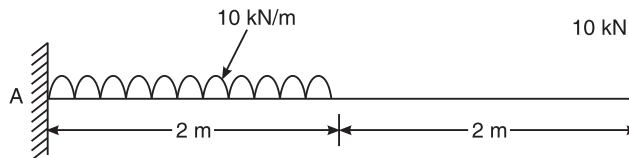

Figure Q.6(b)

- (c) Find reaction at A and B for beam shown in Figure Q.6(c). **(12 Marks)**

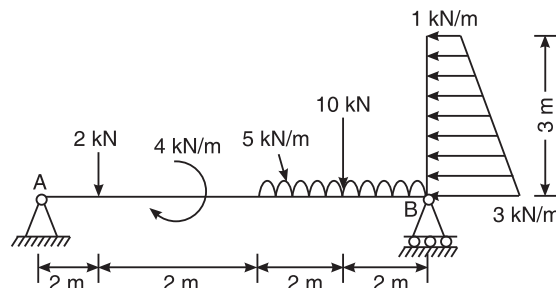

Figure Q.6(c)

442 EXAMINATION PAPERS OF VTU

7. (a) (i) Coefficient of friction (μ) is given by **(04 Marks)**

(A) $\mu = F.R$ (B) $\mu = \frac{F}{R}$ (C) $\mu = \frac{R}{F}$ (D) $\mu = F^2$

(ii) If ϕ = angle of friction and μ = coefficient of friction, then which equation is valid?

(A) $\tan \phi = \mu$ (B) $\tan \phi = 1/\mu$ (C) $\sin \phi = \mu$ (D) $\cos \phi = \mu$

(iii) If ϕ = angle of friction and α = angle of repose then which relation is correct?

(A) $\phi = 1/\alpha$ (B) $\phi = \alpha$ (C) $\phi = \tan \alpha$ (D) $\alpha = \tan \phi$

(iv) Force of friction developed at contact surface is

- (A) Opposite to the direction of motion
 (B) Along the direction of motion
 (C) Perpendicular to plane
 (D) All of the above

(b) State the laws of friction. **(04 Marks)**

(c) A small block of weight = 1000 N is placed on a 30° incline with coefficient of friction = 0.25 as shown in Figure Q.7(c). Find the horizontal force P required to be applied for:

(i) Impending motion down the plane

(ii) Impending motion up the plane

(12 Marks)

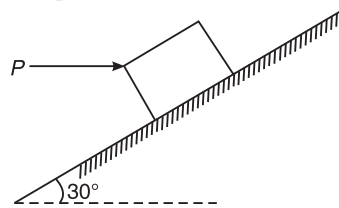

Figure Q.7(c)

8. (a) (i) The unit of moment of inertia of an area is **(04 Marks)**

(A) m^3 (B) m^2 (C) m^4 (D) N/m^2

(ii) The moment of inertia of a square of side " b " about the centroidal axis is:

(A) $\frac{b^4}{8}$ (B) $\frac{b^4}{36}$ (C) $\frac{b^4}{12}$ (D) $\frac{b^3}{12}$

(iii) The moment of inertia of a triangle of base " b " and height " h " about its base is

(A) $\frac{bh^3}{36}$ (B) $\frac{bh^4}{36}$ (C) $\frac{hb^3}{12}$ (D) $\frac{bh^3}{12}$

(iv) The polar moment of inertia of a circular section of diameter " D " about its centroidal axis is

(A) $\frac{\pi}{64}D^4$ (B) $\frac{\pi}{32}D^4$ (C) $\frac{\pi}{32}D^3$ (D) $\frac{\pi}{16}D^4$

(b) Derive the equation of moment of inertia of rectangular section about its centroidal axis from the first principles. **(04 Marks)**

- (c) Find the polar moment of inertia of the section shown in Figure Q.8(c), about an axis passing through its centroid and hence find polar radius of gyration. **(12 Marks)**

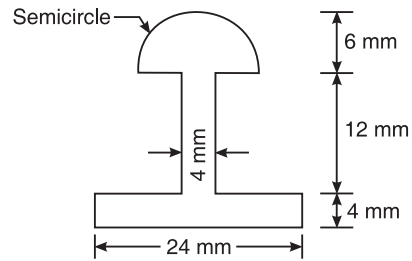

Figure Q.8(c)

First and Second Semester B.E. Degree Examination, June/July, 2009

**ELEMENTS OF CIVIL ENGINEERING AND
ENGINEERING MECHANICS**

Time: 3 hrs.

Max. Marks: 100

- Note:** 1. Answer any FIVE full questions, choosing at least two from each part.
2. Answer all objective type questions only in OMR sheet page 5 of the Answer Booklet.
3. Answer to the objective type questions on sheets other than OMR will not be valued.

PART-A

1. (a) (i) A branch of civil engineering dealing with the technical measures to use and protect the components of environment is **(04 Marks)**
(A) Transportation engineering (B) Hydraulics engineering
(C) Geotechnical engineering (D) Environmental engineering
- (ii) Composite material consisting of cement concrete and steel used in civil engineering structural construction is
(A) Pre Stressed Concrete (PSC)
(B) Reinforced Cement Concrete (RCC)
(C) Fibre Reinforced Concrete (FRC)
(D) Plain Cement Concrete (PCC)
- (iii) Highways which are superior to National Highways and are provided wherever volume of traffic is very high are
(A) State Highways (B) Roadways
(C) Airways (D) Expressways
- (iv) A bridge constructed at some angle to river flow is
(A) Skew bridge (B) Square bridge
(C) Steel bridge (D) Lift bridge
- (b) Bring out briefly scope of following specialization of civil engineering: **(08 Marks)**
(i) Structural engineering (ii) Transportation engineering
- (c) Write a brief note on role of civil engineering in infrastructure development **(08 Marks)**
2. (a) (i) Forces whose lines of action lie along the same line are **(04 Marks)**
(A) Coplanar parallel forces (B) Collinear forces
(C) Coplanar concurrent forces (D) Coplanar non-concurrent forces
- (ii) An object regarded as only mass but no size in mechanics is
(A) Point force (B) Rigid body
(C) Deformable body (D) Particle
- (iii) Moment of a force about a moment centre is the measure of its
(A) Translatory effect (B) Rotational effect
(C) Both (A) and (B) (D) None of these

- (iv) The translatory affect of a couple on the rigid body is
 (A) Positive (B) Negative (C) Zero (D) None of these
- (b) State and explain basic idealizations in mechanics. **(06 Marks)**
- (c) Find moment of force about A and B for the 30 kN force shown in Figure Q.2(c). **(05 Marks)**

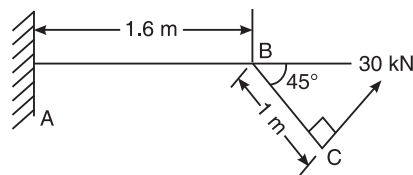

Figure Q.2(c)

- (d) A door needs 7500 N-mm to open it. Mr. X applies the force at the edge of the door shutter which is at a distance of 750 mm from hinge, and Mr. Y applies it at a distance of 500 mm from the hinge. What forces have they to apply to open the door? **(05 Marks)**
3. (a) (i) Component of a force at right angles to its line of action is **(04 Marks)**
 (A) Zero (B) Positive (C) Negative (D) None of these
- (ii) If two concurrent forces each of P act at right angles to each other, their resultant is
 (A) $2P$ (B) P (C) $P\sqrt{2}$ (D) $2\sqrt{P}$
- (iii) The resultant force of two concurrent forces become maximum and minimum if angle between them is
 (A) 0° and 180° (B) 0° and 90°
 (C) 90° and 0° (D) None of these
- (iv) A rigid body acted upon by coplanar non-concurrent forces system has
 (A) Both translatory and rotary motion
 (B) Translatory motion in one direction and rotary motion about itself
 (C) Under rest completely
 (D) All of the above

A truck is to be pulled along a straight road as shown in Figure Q.3(b).

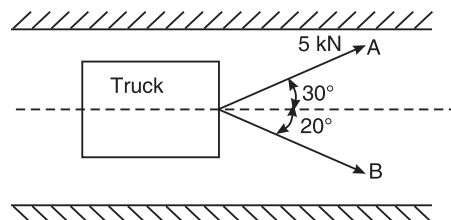

Figure Q.3(b)

446 EXAMINATION PAPERS OF VTU

- (b) (i) If the force applied along rope A is 5 kN inclined at 30° , what should be the force in the rope B, which is inclined at 20° , so that vehicle moves along the road?
 (ii) If force of 4 kN is applied in rope B at what angle rope B should be inclined so that the vehicle is pulled along the road? **(06 Marks)**
- (c) Determine the magnitude, direction and point of application of the resultant force for the system of coplanar forces shown in Figure 3(c). Locate position w.r.t O? **(10 Marks)**

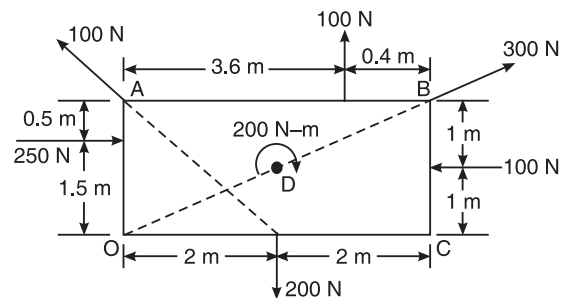

Figure Q.3(c)

4. (a) (i) Centroid of plane is the point at which **(04 Marks)**
 (A) Volume of body concentrated
 (B) Surface area is assumed to be concentrated
 (C) Weight of the body assumed to be concentrated
 (D) All of the above
- (ii) Centroid of quarter of circular lamina lies from diameter line at a distance of
 (A) $\frac{2R}{3\pi}$ (B) $\frac{3R}{3\pi}$ (C) $\frac{4R}{3\pi}$ (D) $\frac{5R}{3\pi}$
- (iii) Centroid of trapezium of height 'h' and parallel sides 'a' and 'b' measured from base 'b' is at a distance of
 (A) $\frac{h}{2} \left(\frac{b+2a}{a+b} \right)$ (B) $\frac{h}{2} \left(\frac{b-2a}{a+b} \right)$
 (C) $\frac{h}{3} \left(\frac{b+2a}{a+b} \right)$ (D) $\frac{h}{3} \left(\frac{b-2a}{a+b} \right)$
- (iv) The centroid of a triangular lamina of height 'h' is situated at a distance $\frac{2h}{3}$ from its apex.
 (A) $\frac{h}{3}$ (B) $\frac{2h}{3}$ (C) $\frac{h}{2}$ (D) $\frac{h}{4}$
- (b) Locate centroid of quadrant of circular lamina from first principle. **(06 Marks)**

(c) Locate centroid of lamina shown in Figure Q.4(c) with respect to point A. (10 Marks)

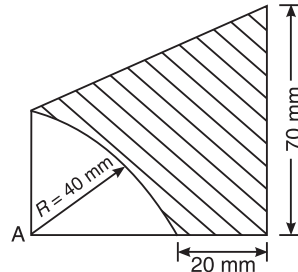

Figure Q.4(c)

PART-B

5. (a) (i) A rigid body is in equilibrium if the resultant force of concurrent force system is (04 Marks)

- (A) Positive (B) Negative (C) Zero (D) None of these

(ii) A system of force that possesses resultant force move in

- (A) The direction of line of action of resultant
(B) Opposite to the direction of line of action of resultant
(C) Perpendicular to the direction of line of action of resultant
(D) None of the above

(iii) Lami's theorem valid for

- (A) Two concurrent forces in equilibrium
(B) Four concurrent forces in equilibrium
(C) Three concurrent forces in equilibrium
(D) None of the above

(iv) For a smooth spherical surface reaction acts

- (A) Horizontal to the plane of contact
(B) Inclined to the plane of contact
(C) Perpendicular to the plane of contact
(D) None of the above

(b) Investigate whether the given system of forces shown in Figure Q.5(b) (i) and (ii) are in equilibrium or not. If not state the type of motion that exist. (06 Marks)

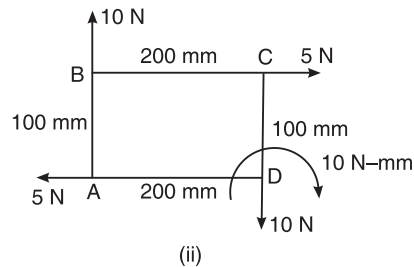
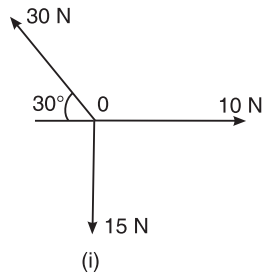

Figure Q.5(b)

448 EXAMINATION PAPERS OF VTU

- (c) Three cylinders weighing 500 N each 24 units in diameter are placed in channel as shown in Figure Q.5(c). Determine reactions at all contact points. Take cylinders are smooth. **(10 Marks)**

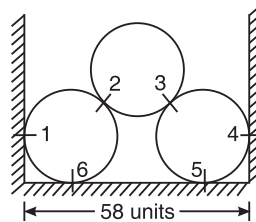

Figure Q.5(c)

6. (a) (i) Reaction line at roller support with respect to plane of contact is **(04 Marks)**
(A) Oblique (B) Obtuse
(C) Perpendicular (D) None of these
- (ii) Support reactions for statically determined beams can be determined by applying
(A) Conditions of static equilibrium
(B) Lami's theorem
(C) Varignon's principle
(D) None of the above
- (iii) When load acts at constant rate over given length of beam it is called
(A) Point load (B) udl
(C) UVL (D) None of these
- (iv) A beam having one end hinged support and other roller support subjected to vertical loading can be regarded as
(A) Fixed beam (B) Cantilever beam
(C) Simply supported beam (D) None of these
- (b) With sketch, explain different types of supports and mark reaction line. **(06 Marks)**
- (c) A beam ABCDE has a flexible link BC as shown in Figure Q.6(c). Determine the support reaction at A, D and E. **(10 Marks)**

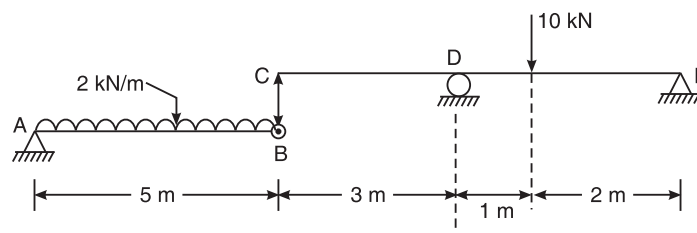

Figure Q.6(c)

7. (a) (i) The maximum frictional force developed when a body just begins to slide over the surface of an another body is **(04 Marks)**
- (A) Sliding friction (B) Rolling friction
(C) Limiting friction (D) None of these
- (ii) The angle which an inclined surface makes with the horizontal when a body placed on it is in the verge of moving down, is called
- (A) Angle of repose (B) Angle of friction
(C) Angle of inclination (D) None of these
- (iii) Frictional force is independent of
- (A) Coefficient of friction
(B) Angle of friction
(C) Shape and size of surface of contact
(D) None of the above
- (iv) Compared to static friction, kinetic friction is
- (A) Greater (B) Smaller (C) Very large (D) Zero
- (b) Briefly explain: (i) Angle of friction (ii) Angle of repose and (iii) Cone of friction **(06 Marks)**
- (c) A uniform bar AB 5 m long weighing 280 N is hinged at B, rest upon 400 N block at A as shown in Figure Q.7(c). If coefficient of friction is 0.4 for all contact surfaces, find the horizontal force P required to move the 400 N block. **(10 Marks)**

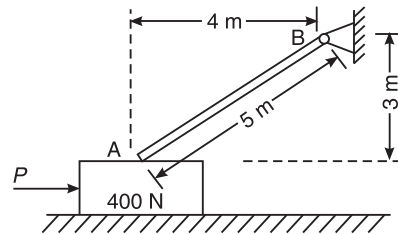

Figure Q.7(c)

8. (a) (i) Moment of inertia is a **(04 Marks)**
- (A) First moment of area (B) Second moment of area
(C) Third moment of area (D) None of the above
- (ii) M.I. of circular section about centroidal axis is
- (A) $\frac{\pi D^4}{48}$ (B) $\frac{\pi D^4}{32}$ (C) $\frac{\pi D^4}{64}$ (D) $\frac{\pi D^4}{128}$
- (iii) M.I. of triangular section about base having base b and height h is
- (A) $\frac{bh^3}{36}$ (B) $\frac{bh^3}{12}$ (C) $\frac{bh^3}{64}$ (D) None of these

450 EXAMINATION PAPERS OF VTU

- (iv) M.I. of hollow circular section whose external diameter is 8 mm and internal diameter 4 mm about centroidal axis is
(A) 437.5 mm^4 (B) 337.5 mm^4 (C) 237.5 mm^4 (D) 137.5 mm^4
- (b) State and prove perpendicular axis theorem. **(06 Marks)**
- (c) Compute moment of inertia of the shaded area about centroidal axis shown in Figure Q.8(c). **(10 Marks)**

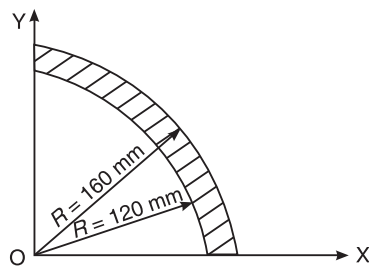

Figure Q.8(c)

First and Second Semester B.E. Degree Examination, Dec. 2008/Jan. 2009

**ELEMENTS OF CIVIL ENGINEERING AND
ENGINEERING MECHANICS**

Time: 3 hrs.

Max. Marks: 100

- Note:** 1. Answer any FIVE full questions selecting at least two questions from each part.
2. Answer all objective type questions only in first and second writing pages.
3. Answer for objective type questions shall not be repeated.
4. Missing data if any may be suitably assumed and indicated.

PART-A

1. (a) (i) Geotechnical Engineering involves the study of **(04 Marks)**
(A) Water (B) Soil (C) Air (D) All of these
- (ii) By-pass road is constructed
(A) Inside the city (B) Over the main road
(C) Around the city (D) None of these
- (iii) The part of civil engineering which deals with waste water and solid waste is called
(A) Water supply Engineering (B) Geotechnical Engineering
(C) Sanitary Engineering (D) Structural Engineering
- (iv) A bascule bridge is a
(A) Floating bridge (B) Arch bridge
(C) Suspension bridge (D) Movable bridge
- (b) Write a note on role of civil engineer in infrastructural development. **(10 Marks)**
- (c) Name the different types of roads. **(06 Marks)**
2. (a) (i) Moment of a force can be defined as the product of force and _____ distance from the line of action of force to the moment centre. **(04 Marks)**
(A) Least (B) Maximum (C) Any (D) None of these
- (ii) Effect of force on a body depends on
(A) Direction (B) Magnitude (C) Position (D) All of these
- (iii) The forces which meet at one point and have their line of action in different planes are called
(A) Coplanar concurrent forces
(B) Non-coplanar concurrent forces
(C) Non-coplanar non-concurrent forces
(D) None of the above
- (iv) Couple means two forces acting parallel
(A) Equal in magnitude and in the same direction
(B) Not equal in magnitude but in the same direction
(C) Equal in magnitude but opposite in direction
(D) None of the above

452 EXAMINATION PAPERS OF VTU

- (b) State the Newton's three laws of the motion. **(06 Marks)**
- (c) Define force and state its characteristics. **(05 Marks)**
- (d) Replace the horizontal 600 N force acting on the lever as shown Figure Q.2(d) by an equivalent system consisting of a force and a couple at O. **(05 Marks)**

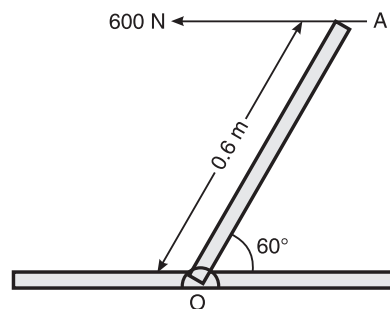

Figure Q.2(d)

3. (a) (i) The technology of finding the resultant of a system of forces is called **(04 Marks)**
(A) Resultant (B) Resolution (C) Composition (D) None of the above
- (ii) Equilibrant is nothing but a resultant
(A) Equal in magnitude and in the same direction
(B) Equal in magnitude but opposite in direction
(C) Not equal in magnitude but in the same direction
(D) Not equal in magnitude and opposite in direction
- (iii) If two forces P and Q ($P > Q$) act on the same straight line but in opposite direction their resultant is
(A) $P + Q$ (B) P/Q (C) $Q - P$ (D) $P - Q$
- (iv) In a coplanar concurrent force system if $\Sigma H = 0$, then the resultant is
(A) Horizontal (B) Vertical (C) Moment (D) None of the above
- (b) State and prove Varignon's theorem of the moments. **(06 Marks)**
- (c) Determine the magnitude, direction of the resultant force for the force system shown in Figure Q.3(c). Determine the X -intercept of the resultant force with respect to the point O. **(10 Marks)**

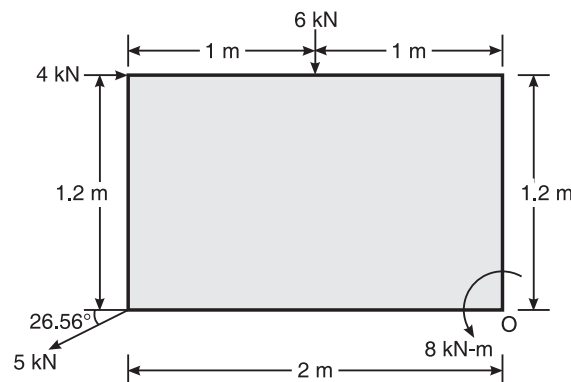

Figure Q.3(c)

4. (a) (i) Moment of a total area about its centroidal axis is **(04 Marks)**
 (A) Twice the area (B) Three times the area
 (C) Zero (D) None of these
- (ii) The centroid of a semicircle of radius R about its centroidal axis parallel to its diametric axis is
 (A) $3R/4\pi$ (B) $3R/8\pi$ (C) $4R/\pi$ (D) $4R/3\pi$
- (iii) An axis over which one half of the plane figure is just mirror of the other half which is
 (A) Bottom-most axis of the figure
 (B) Axis of symmetry
 (C) Unsymmetrical axis
 (D) None of the above
- (iv) Centroid of a rectangle of a triangle with base b and depth d is
 (A) $b/3$ and $d/3$ (B) $b/2$ and $d/2$
 (C) $b/4$ and $d/4$ (D) None of these
- (b) Determine the centroid of a triangle by the method of integration. **(06 Marks)**
- (c) Locate the centroid of an area shown in Figure Q.4(c), with respect OX and OY . All dimensions are in mm. **(10 Marks)**

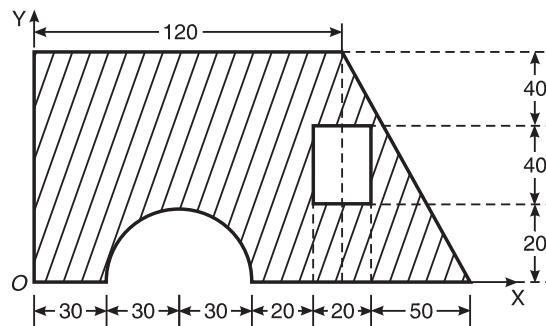

Figure Q.4(c)

PART-B

5. (a) (i) A rigid body is in equilibrium under the action of three forces. It implies that the forces must be such that the **(04 Marks)**
 (A) Resultant is zero (B) Equilibrant is zero
 (C) Both A and B (D) None of these
- (ii) Lami's theorem
 (A) Relates the forces with the sines of angles
 (B) Relates the action of three concurrent forces and sines of angles
 (C) May be applied to consider relationship between forces
 (D) May be applied for a body which may or may not be in equilibrium

454 EXAMINATION PAPERS OF VTU

- (iii) If sum of all the forces acting on a body is zero, it may be concluded that the body
- (A) Must be in equilibrium
 - (B) Cannot be in equilibrium
 - (C) May be in equilibrium provided the forces are concurrent
 - (D) May be in equilibrium provided the forces are parallel
- (iv) The necessary condition of equilibrium of concurrent force system is
- (A) The algebraic sum of horizontal and vertical forces must be zero
 - (B) The algebraic sum of moments of forces must be zero
 - (C) The algebraic sum of horizontal, vertical and moments of forces must be zero
 - (D) All of the above
- (b) Define free body diagram. Describe types of forces acting on a body. Explain them in brief. **(06 Marks)**
- (c) A wire rope is fixed at two points A and D as shown in Figure Q.5(c). Weights 20 kN and 30 kN are attached to it at B and C respectively. The weights rest with portions AB and BC inclined at 30° and 50° respectively, to the vertical as shown. Find the tension in segments AB, BC and CD of the wire. Determine the inclination of the segment CD to vertical (θ). **(10 Marks)**

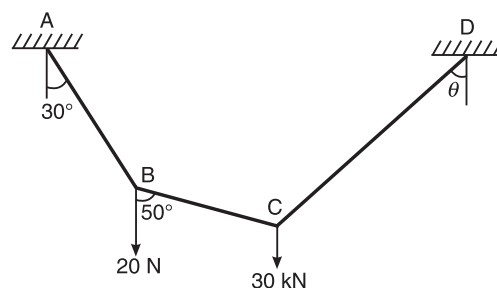

Figure Q.5(c)

6. (a) (i) A beam is said to be determinate, if **(04 Marks)**
- (A) The reactions can be determined using the equations of equilibrium
 - (B) The reactions cannot be determined using the equations of equilibrium
 - (C) The reactions can be determined by using the force equilibrium conditions
 - (D) The reactions can be determined by using the moment equilibrium condition only
- (ii) The beam is neither permitted to move in any direction nor allowed to rotate in the case of
- (A) Hinged support
 - (B) Fixed support
 - (C) Roller support
 - (D) Simple support
- (iii) UVL stands for
- (A) Uniform vertical load
 - (B) Uniform velocity load
 - (C) Uniform vague load
 - (D) Uniformly varying load
- (iv) A thin rigid beam hinged at one end and roller-supported at its mid-point is said to be
- (A) A simply supported beam
 - (B) A overhanging beam
 - (C) A cantilever beam
 - (D) A fixed beam

(b) Differentiate between resultant and equilibrant **(04 Marks)**

(c) Determine the reactions at the supports for the system shown in Figure Q.6(c). **(12 Marks)**

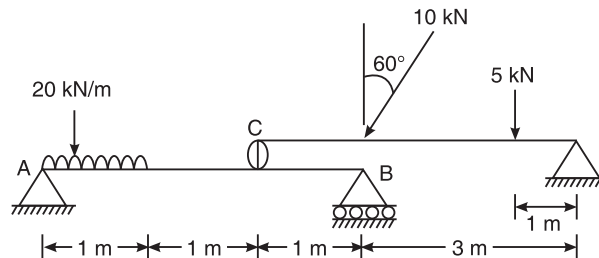

Figure Q.6(c)

7. (a) (i) The frictional force is independent of **(04 Marks)**

- (A) The area of contact (B) The coefficient of friction
(C) The normal reaction (D) The angle of friction

(ii) Once a body just begins to slide, it continues to slide because

- (A) The body has inertia (B) Inertia force acts on the body
(C) The body accelerates (D) The frictional force becomes less

(iii) The coefficient of friction between two surfaces is the constant of proportionality between the applied tangential force and the normal reaction

- (A) At the instant of application of the force
(B) At any instant when the body is at rest
(C) At the instant of impending motion
(D) At an instant after the motion takes place

(iv) The angle of friction is angle between

- (A) The incline and the horizontal
(B) The normal reaction and frictional force
(C) The weight of the body and the friction force
(D) The normal reaction and the resultant

(b) Define coefficient of friction. Show that the coefficient of friction is tangent of the angle of friction. **(04 Marks)**

(c) In the Figure Q.7(c), determine the minimum value of P, just required to lift 3000 N up. The angle of friction between block and the wall is 15° and for other surfaces it is 18° . **(12 Marks)**

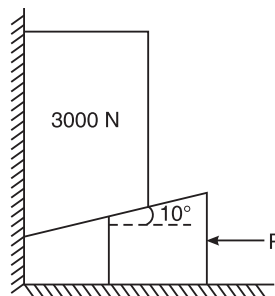

Figure Q.7(c)

456 EXAMINATION PAPERS OF VTU

8. (a) (i) The moment of inertia of a rectangular lamina of sides 'b' and 'h' about its neutral axis parallel to the sides 'b' is given by **(04 Marks)**
- (A) $\frac{bh^3}{12}$ (B) $\frac{bh^3}{36}$ (C) $\frac{hb^3}{12}$ (D) $\frac{hb^3}{36}$
- (ii) The unit of radius of gyration of an area is
- (A) N/m (B) N/m² (C) m³ (D) m
- (iii) The value of moment of inertia depends upon
- (A) Type of material (B) Weight of material
(C) Density of material (D) Cross-sectional dimensions
- (iv) Moment of inertia is a
- (A) First order term (B) Second order term
(C) Fourth order term (D) Third order term
- (b) State the parallel axis theorem. **(02 Marks)**
- (c) Explain the polar moment of inertia and the radius of gyration. **(04 Marks)**
- (d) Find the moment of inertia of the area shown in Figure Q.8(d) about its centroidal axis parallel to the coordinate axis. **(10 Marks)**

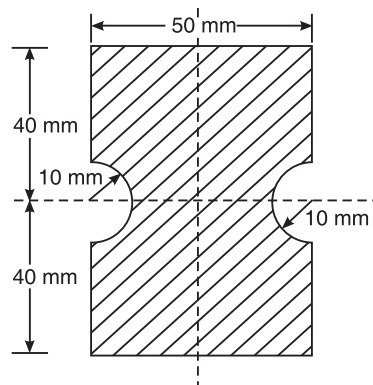

Figure Q.8(d)

**First and Second Semester B.E. Degree Examination, Dec. 2006/Jan. 2007
Common to All Branches**

**ELEMENTS OF CIVIL ENGINEERING AND
ENGINEERING MECHANICS**

Time: 3 hrs.

Max. Marks: 100

Note: Answer any Five full questions.

1. (a) List the various civil engineering amenities covered under infrastructural development. **(06 Marks)**
- (b) What are the different bases under which the dams are classified? **(08 Marks)**
- (c) Write short notes on:
 - (i) Shoulders
 - (ii) Kerbs**(06 Marks)**
2. (a) State the Newton's three laws of motion. **(06 Marks)**
- (b) State and explain the principle of transmissibility of forces. **(04 Marks)**
- (c) A force of 200 N is acting on a block as shown in Figure Q.2(c), find the components of forces along the horizontal and vertical axes. **(05 Marks)**

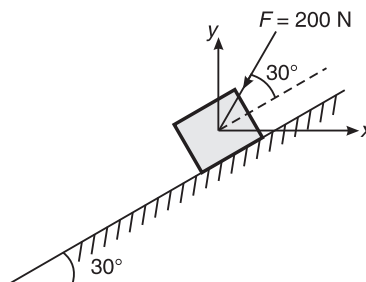

Figure Q.2(c)

- (d) Find the moment of force $F = 600\text{ N}$ about 'A' as shown in Figure Q.2(d). **(05 Marks)**

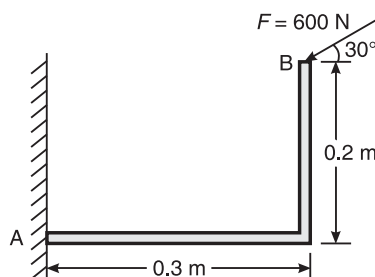

Figure Q.2(d)

3. (a) State and explain the parallelogram law of forces. **(05 Marks)**
(b) Determine the resultant force acting on the structure at point O both in magnitude and direction. Refer to Figure Q.3(b). **(07 Marks)**

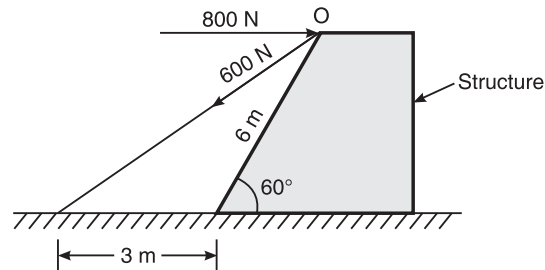

Figure Q.3(b)

- (c) Determine the magnitude, direction of the resultant force for the force system shown in Figure Q.3(c). Locate the resultant force with respect to point D. **(08 Marks)**

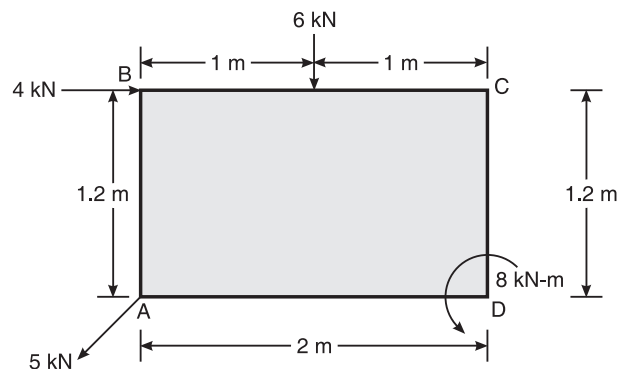

Figure Q.3(c)

4. (a) Define centroid and centroidal axis. **(04 Marks)**
(b) Derive an expression for the coordinates for the position of centroid of rectangle. **(08 Marks)**
(c) Determine the position of centroid with respect to 'O', shown in Figure Q.4(c). **(08 Marks)**

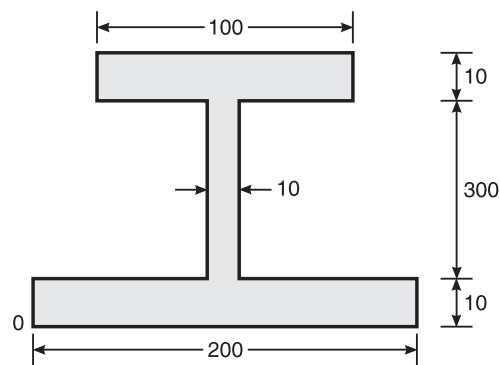

Figure Q.4(c)

5. (a) Define:
(i) Free body diagram.
(ii) Action and reaction at a point of contact of bodies in equilibrium. **(04 Marks)**
(b) Compute the tensions in the strings AB, BC and CD shown in Figure Q.5(b). **(06 Marks)**

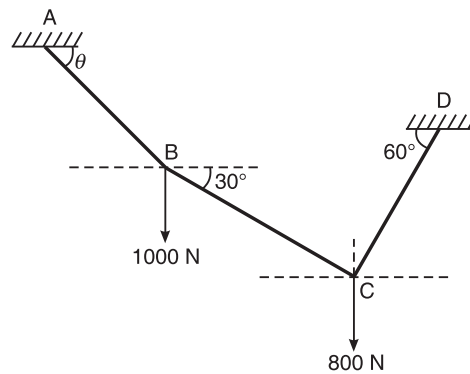

Figure Q.5(b)

- (c) Two spheres each of radius 100 mm and weight 5 kN are in a rectangular box as shown in Figure Q.5(c). Calculate the reactions at all the points of contact. **(10 Marks)**

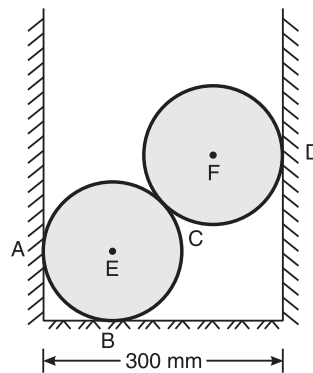

Figure Q.5(c)

6. (a) Determine the distance x such that the reactions R_A and R_B are equal, for the beam shown in Figure Q.6(a). **(08 Marks)**

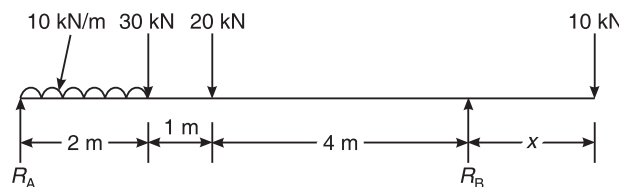

Figure Q.6(a)

- (b) Determine the support reactions of the overhanging beam shown in Figure Q.6(b).
(12 Marks)

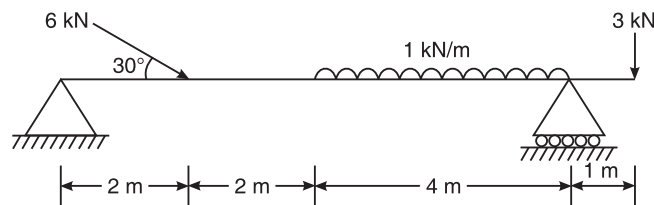

Figure Q.6(b)

7. (a) Distinguish between
(i) Dry friction and fluid friction
(ii) Static friction and kinetic friction. (08 Marks)
- (b) Determine the force P required to start the movement of the wedge as shown in Figure Q.7(b). The angle of friction for all surfaces of contact is 15° .

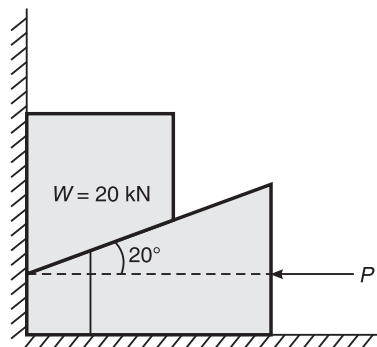

Figure Q.7(b)

8. (a) Determine the moment of inertia of a circle about its diametral axis by the method of integration. (06 Marks)
- (b) Determine the moment of inertia and radii of gyration of the area shown in Figure Q.8(b) about the base AB and the centroidal axis parallel to AB. All dimensions are in mm.

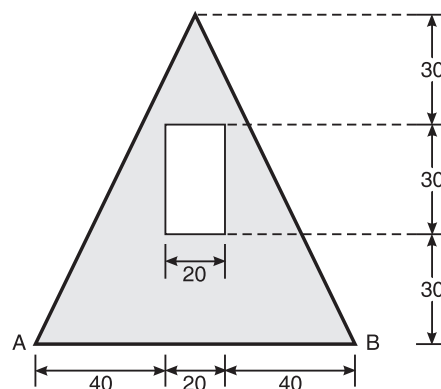

Figure Q.8(b)

**First and Second Semester B.E. Degree Examination, July 2007
Common to All Branches**

**ELEMENTS OF CIVIL ENGINEERING AND
ENGINEERING MECHANICS**

Time: 3 hrs.

Max. Marks: 100

Note: Answer any Five full questions choosing at least two questions from each part.

PART-A

1. (a) Discuss briefly the impact of civil engineering infrastructural developments on the national economy and environment. **(09 Marks)**
(b) Draw a neat sketch of divided highway in urban areas. **(05 Marks)**
(c) Write short notes on kerbs and shoulders. **(06 Marks)**
2. (a) Explain the following terms:
(i) Rigid body
(ii) Point source **(04 Marks)**
(b) Explain the different types of force systems giving an example for each one of them. **(06 Marks)**
(c) The moment of a certain force F is 180 kN-m clockwise about O and 90 kN-m counterclockwise about B. If its moment about A is zero, determine the force F . **(10 Marks)**

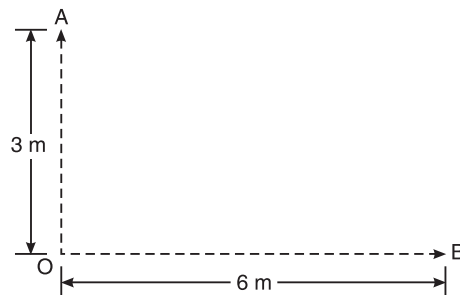

Figure Q.2(c)

462 EXAMINATION PAPERS OF VTU

3. (a) State and explain principle of resolved parts. **(05 Marks)**
(b) Forces are transmitted by two members as shown in Figure Q.3(b). If the resultant of these forces is 1400 N directed vertically up, determine the values of angles α and β . **(07 Marks)**

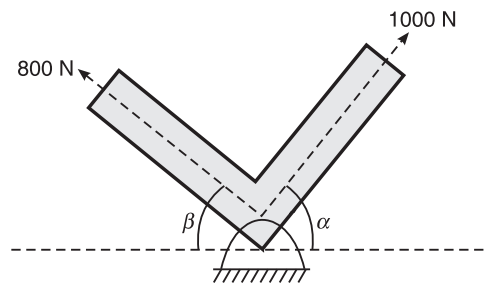

Figure Q.3(b)

- (c) ABCD is a square whose sides are 2 m each. Along AB, BC, CD and DA, the forces equal to 1, 2, 8 and 5 and along AC and DB forces equal to $5\sqrt{2}$ and $2\sqrt{2}$ act respectively. Find the resultant of the force system. All the forces are in kN. **(08 Marks)**
4. (a) Explain the method of moments for determining the position of centroid. **(03 Marks)**
(b) Distinguish between centroid and centre of gravity. **(04 Marks)**
(c) Determine the position of the centroid of the plane shown in Figure Q.4(c) with respect to the base. All dimensions are in mm. **(13 Marks)**

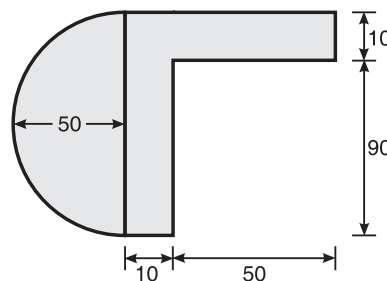

Figure Q.4(c)

PART-B

5. (a) State and prove Lami's theorem. **(05 Marks)**
(b) Draw the free body diagram of sphere shown in Figure Q.5(b) and determine the reactions at the points of contact using Lami's theorem. **(05 Marks)**

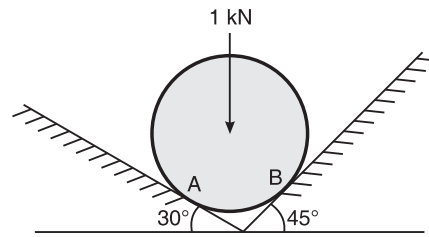

Figure Q.5(b)

- (c) In Figure Q.5(c) the portion BC of the string is horizontal and pulley is frictionless. Determine tension in different parts of the string. Also find W_1 and W_2 . **(10 Marks)**

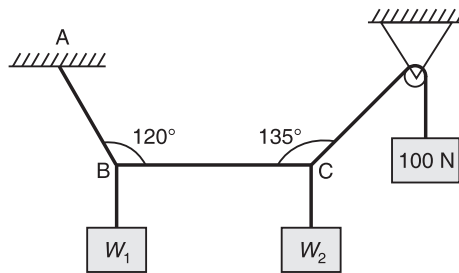

Figure Q.5(c)

6. (a) Explain the types of loading on the beams. **(05 Marks)**
(b) Determine the distance x of the load P from the support A, if the reaction R_A is twice as great as reaction R_B . Take $P = 2$ kN, $Q = 1$ kN. See Figure Q.6(b). **(05 Marks)**

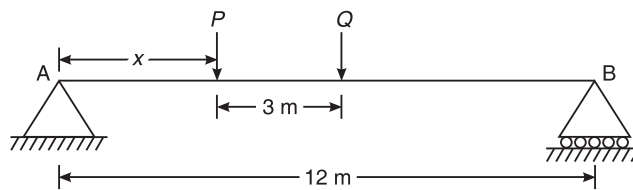

Figure Q.6(b)

464 EXAMINATION PAPERS OF VTU

- (c) A simply supported beam of length 10 m, carries the uniformly distributed load and two point loads as shown in Figure Q.6(c). Calculate the reactions R_A and R_B . (10 Marks)

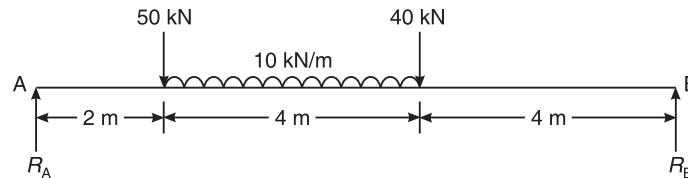

Figure Q.6(c)

7. (a) Explain the terms: (06 Marks)

- (i) Angle of repose
- (ii) Cone of friction.

- (b) What is the value of P in the system shown in Figure Q.7(b) to cause the motion to impend? Assume the pulley is smooth and the coefficient of friction between the other contact surface is 0.2. (14 Marks)

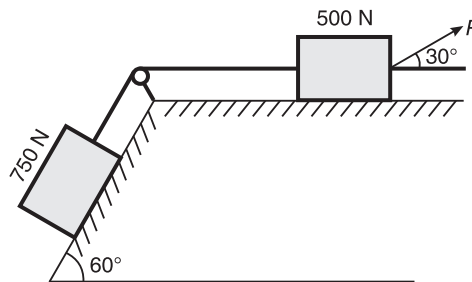

Figure Q.7(b)

8. (a) State and prove parallel axes theorem of moment of inertial. (06 Marks)

- (b) The cross section of the prestressed concrete beam is as shown in Figure Q.8(b). Calculate the moment of inertia of this section about the centroidal axes parallel to the top edge and perpendicular to the plane of cross section. Also determine the radius of gyration. (14 Marks)

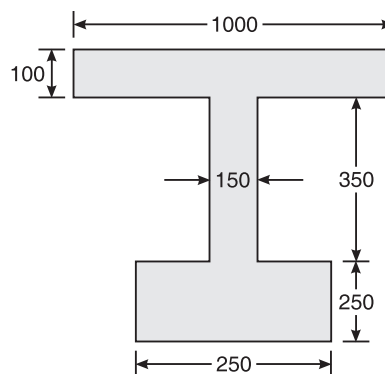

Figure Q.8(b)

First and Second Semester B.E. Degree Examination, Dec. 2007/Jan. 2008

**ELEMENTS OF CIVIL ENGINEERING AND
ENGINEERING MECHANICS**

Time: 3 hrs.

Max. Marks: 100

Note: Answer any Five full questions, selecting at least two questions from each part.

PART-A

1. (a) Explain briefly the role of civil engineer in the infrastructural development of a nation. **(05 Marks)**
(b) Explain briefly the scope of civil engineering in:
(i) Water resources engineering, **(08 Marks)**
(i) Geotechnical engineering
(c) Explain different types of roads. **(07 Marks)**
2. (a) Explain briefly the rigid body concept. **(04 Marks)**
(b) Distinguish between: **(06 Marks)**
(i) Resolution and composition
(ii) Moment and couple
(iii) Force and force system
(c) State and explain principle of transmissibility of a force. What are its limitations? **(05 Marks)**
(d) Replace the force-couple system by a single force with respect to AB and CD shown in Figure Q.2(d). **(05 Marks)**

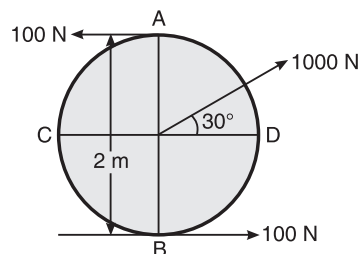

Figure Q.2(d)

3. (a) State and prove Varignon's theorem. **(05 Marks)**
(b) Determine the force F and its inclination α required, so as to lift a block of weight 500 N as shown in Figure Q.3(b). **(05 Marks)**

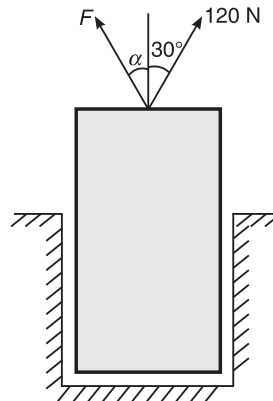

Figure Q.3(b)

- (c) Determine the resultant of the force system acting on the plate as shown in Figure Q.3(c) with respect to AB and AD. **(10 Marks)**

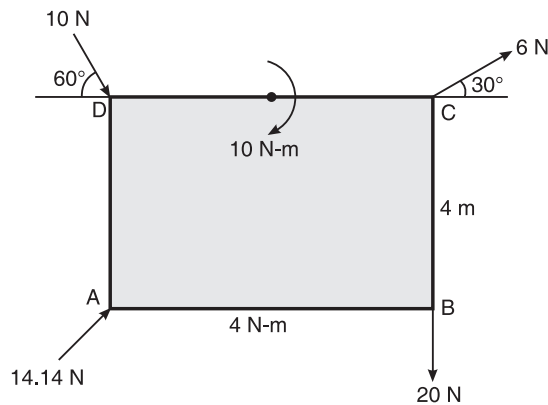

Figure Q.3(c)

4. (a) Distinguish between centroid and centre of gravity. **(04 Marks)**
(b) Determine the centroid for the quarter circular area from first principles. **(06 Marks)**
(c) Determine the position of the centroid for the shaded area with respect to the axes as shown in Figure Q.4(c).

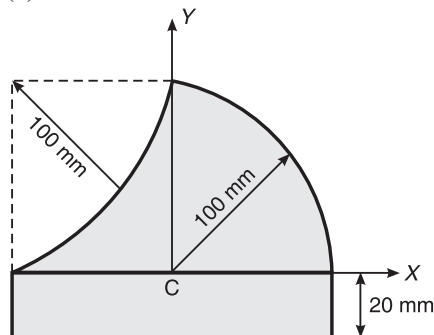

Figure Q.4(c)

PART-B

5. (a) What is meant by equilibrium of a rigid body? State the conditions of static equilibrium force coplanar non-concurrent force system? **(05 Marks)**
(b) Determine the tension in the string and the reaction at the contact surface for the cylinder of weight 1000 N placed as shown in Figure Q.5(b). **(05 Marks)**

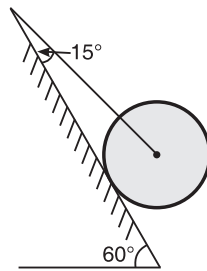

Figure Q.5(b)

- (c) Determine the angle θ for the system of strings ABCD in equilibrium as shown in Figure Q.5(c). **(10 Marks)**

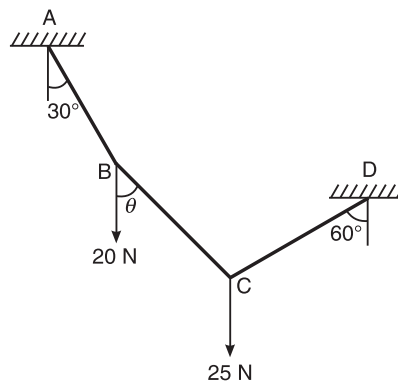

Figure Q.5(c)

6. (a) Define statically determinate beams. **(02 Marks)**
(b) Distinguish between **(04 Marks)**
(i) Hinged support and (ii) roller support.
(c) Determine the position of a 10 N load on the beam such that the reactions at the supports are equal for the beam loaded as shown in Figure Q.6(c). **(05 Marks)**

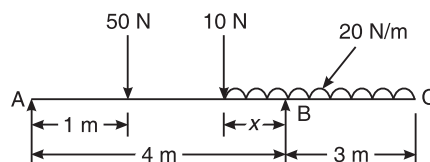

Figure Q.6(c)

- (d) Determine the reactions at the supports for the beam loaded as shown in Figure Q.6(d). **(09 Marks)**

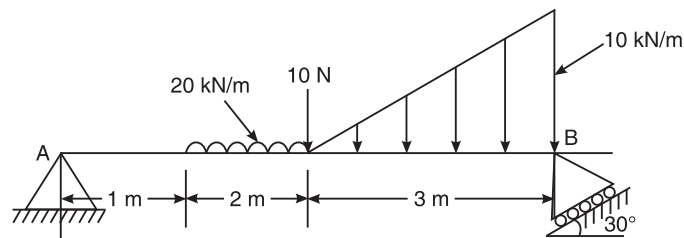

Figure Q.6(d)

7. (a) Define: **(09 Marks)**
- (i) Angle of friction
 - (i) Cone of friction
- (b) A ladder 5 m in length is resting against a smooth vertical wall and a rough horizontal floor. The ladder makes an angle of 60° with the horizontal. When a man of weight 800 N is at the top of the rung, what is the coefficient of friction required at the bottom of the ladder and the floor such that the ladder does not slip? Take the weight of ladder as 200 N. **(08 Marks)**
- (c) Determine the force P required to cause motion of blocks to impend. Take the weight of A as 90 N and weight of B as 45 N. Take the coefficient of friction for all contact surfaces as 0.25 as shown Figure Q.7(c), and consider the pulley being frictionless. **(08 Marks)**

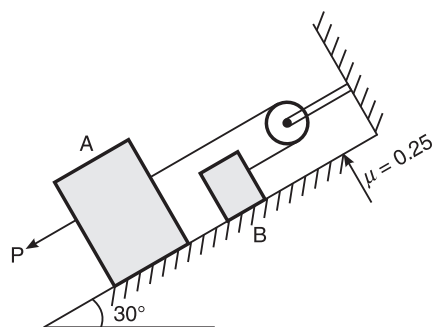

Figure Q.7(c)

8. (a) State and explain the parallel axis theorem. **(06 Marks)**
(b) Determine the second moment of the area about the horizontal centroidal axis as shown in Figure Q.8(b). Also find the radius of gyration. All dimensions are in mm. **(14 Marks)**

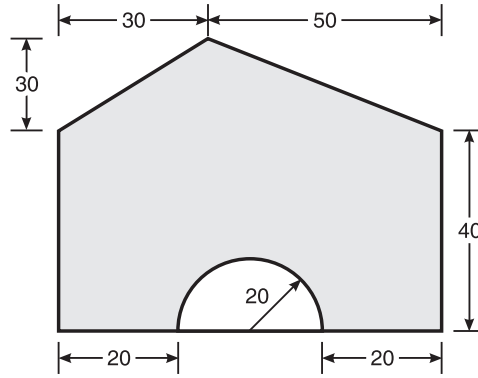

Figure Q.8(b)

First and Second Semester B.E. Degree Examination, June/July 2008

**ELEMENTS OF CIVIL ENGINEERING AND
ENGINEERING MECHANICS**

Time: 3 hrs.

Max. Marks: 100

Note: Answer any Five full questions, choosing at least two questions from each part.

PART-A

1. (a) Explain in brief the scope of civil engineering. **(08 marks)**
(b) Write a note on impact of infrastructural development on the economy of the country. **(06 Marks)**
(c) Explain any two types of dams with neat figures. **(06 Marks)**
2. (a) Define the following: **(10 Marks)**
 - (i) Particle
 - (ii) Rigid body
 - (iii) Continuum
 - (iv) Force
- (b) Explain transmissibility of force.
- (c) Two cables which have known tensions $T_1 = 2$ kN and $T_2 = 4$ kN are attached at the point B of a mast AB. A third cable BC is used as a guy wire and is attached at B. Determine the required tension in cable BC, so that the resultant of the forces exerted by the three cables will be vertical. Also find the magnitude of the resultant. Refer Figure Q.2(c). **(10 Marks)**

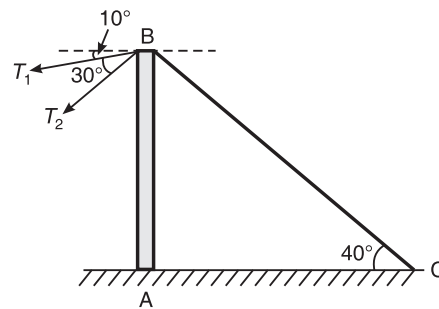

Figure Q.2(c)

3. (a) State and prove: **(10 Marks)**
 - (i) Parallelogram law of forces
 - (ii) Varignon's theorem
- (b) The coplanar forces are acting on a lamina as shown in Figure Q.3(b), where the side of each square is 1 m. Find the magnitude and position of the resultant. **(10 Marks)**

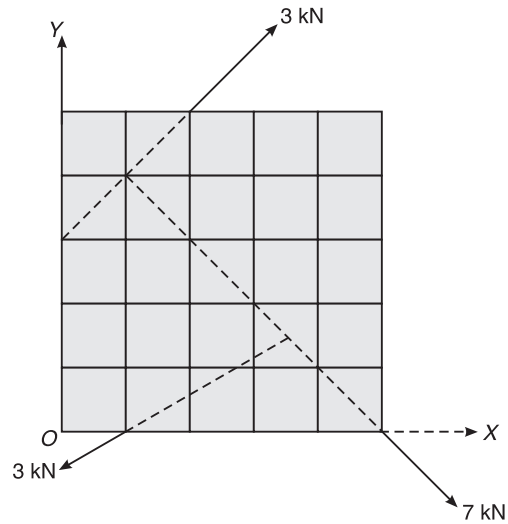

Figure Q.3(b)

4. (a) Define: (03 Marks)
- (i) Centre of gravity
 - (ii) Centroid
 - (iii) Axis of symmetry.
- (b) Determine the centre of gravity of a semicircle by the method of integration. (05 Marks)
- (c) Find the coordinates of centroid of the lamina, shown in Figure Q.4(c) with respect to point A. (12 Marks)

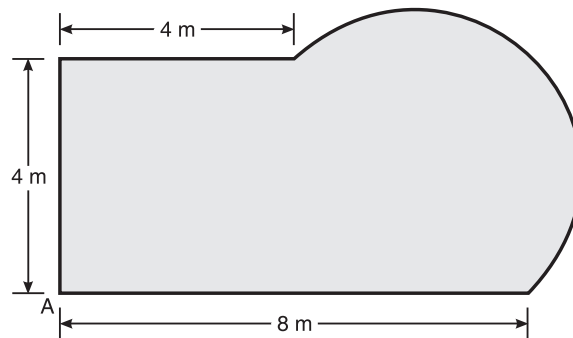

Figure Q.4(c)

PART-B

5. (a) Define the conditions of equilibrium for the coplanar non-concurrent force system. (10 Marks)

472 EXAMINATION PAPERS OF VTU

- (b) Find the magnitude and position of the equilibrant for the set of forces shown in Figure Q.5(b).

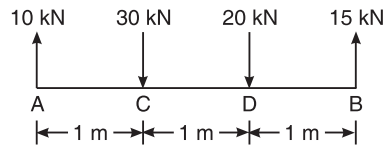

Figure Q.5(b)

- (c) Two cylinders A and B rest in a channel as shown in Figure Q.5(c). The cylinder A has a diameter of 100 mm and weighs 20 kN, B has a diameter of 180 mm and weighs 50 kN. The channel is 180 mm wide at bottom with one side vertical and the other side at 60° inclination. Find the reactions at contact points. **(10 Marks)**

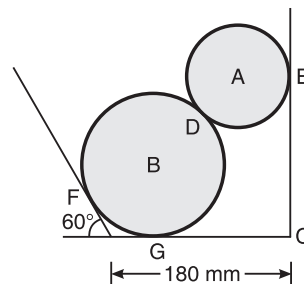

Figure Q.5(c)

6. (a) Explain different types of supports and reactions. **(08 Marks)**
(b) Determine the reactions at the ends of the beams AB and CD as shown in Figure Q.6(b). **(12 Marks)**

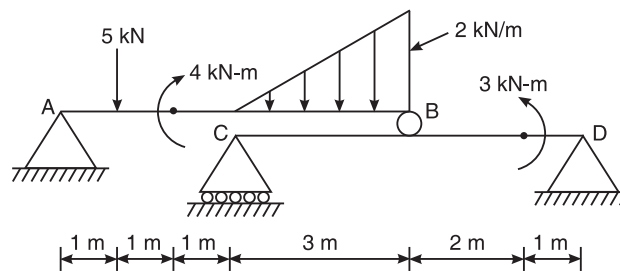

Figure Q.6(b)

7. (a) Mention the laws of static friction. **(05 Marks)**
(b) Define angle of friction and angle of repose. **(05 Marks)**
(c) A uniform ladder of length 20 m, rests against a vertical wall with which it makes an angle of 45°, the coefficient of friction between the ladder and the wall and ground respectively being $\frac{1}{3}$ and $\frac{1}{2}$. If a man, whose weight is one half that of the ladder, ascends the ladder, how high will he be, when the ladder slips? **(10 Marks)**

8. (a) State and prove the parallel axis theorem. **(05 Marks)**
(b) Derive an expression for the moment of inertia of a triangle about the base using the method of integration.
(c) Find the moment of inertia of the section shown in Figure. Q.8(c) about the horizontal centroidal axis and also find the radius of gyration about the same axis. **(10 Marks)**

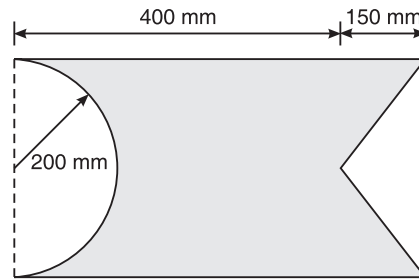

Figure Q.8(c)

SOLUTIONS TO THE EXAMINATION PAPERS OF VTU

June/July 2011 Examination Paper

PART A

1. (a) (i) Geotechnical engineering involves the study of: (B) Soil
(ii) Building tanks and dams and carrying stored water to field is known as: (C) Water resources and irrigation engineering
(iii) The structure which provides passage over the obstacles like valley, river without closing the way underneath is: (B) Bridge
(iv) Highways which are superior to National Highways and are provided wherever volume of traffic is very high are: (D) Expressways
2. (a) (i) Which of the following is the basic concept of mechanics: (C) Force
(ii) When more than three concurrent forces are in equilibrium, select the condition that is satisfied: (D) Polygon representing the forces will close.
(iii) Effect of a force on a body depends upon its: (D) All the above
(iv) Forces coexist on a plane and all the forces act helter-skelter over the body. These are: (A) Coplanar non-concurrent forces.
- (d) A 100 N vertical force is applied to the end of a lever which is attached to a shaft as shown in Figure Q.2(d), determine
 - (i) The moment of force about O
 - (ii) The horizontal force applied at 'A' which creates same moment about 'O'
 - (iii) The smallest force applied at 'A' which creates same moment about 'O'
 - (i) The moment of force about O is

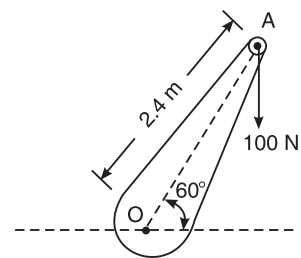

Figure Q.2(d)

$$M_o = 100 \times 2.4 \cos 60^\circ = 120 \text{ Nm}$$

476 SOLUTIONS TO THE EXAMINATION PAPERS OF VTU

- (ii) Let F_h be the horizontal force applied at 'A' which creates same moment about 'O'
- $$= 120 \text{ Nm} = F_h (2.4 \sin 60^\circ) \text{ or } F_h = 57.735 \text{ N}$$
- (iii) For the force to be smallest to create the same moment, the distance and force must be perpendicular to each other and hence if F is the minimum force, it is given by $F \times 2.4 = 120$ or $F = 50 \text{ N}$
3. (a) (i) If two equal forces of magnitude p act an angle θ , their resultant will be (Given choice is wrong) $p\sqrt{2(1 + \cos\theta)}$
- (ii) The simplest resultant of a plane force system is always: (D) A single force or a single moment.
- (iii) The angle between tow forces to make their resultant a minimum and a maximum respectively are: (D) 180° and 0°
- (iv) The moment of a force about any point is numerically equal to _____ times the area of the triangle whose base is the line representing the force and vertex is the point about which the moment is taken: (C) Twice

- (c) Two forces acting on a body are 500 N and 1000 N as shown in Figure Q.3(c). Determine the third force F such that the resultant of all the three forces is 1000 N directed at 45° to the x -axis.

Let F be the third force acting at angle θ from x -axis such that the resultant is as shown in Figure Q.3(c). The algebraic sum of horizontal forces must be equal to the horizontal component of the resultant, i.e.

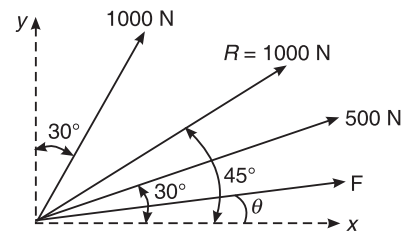

Figure Q.3(c)

$$1000 \cos 45^\circ = 500 \cos 30^\circ + 1000 \sin 30^\circ + F \cos \theta$$

$$F \cos \theta = 1000 \cos 45^\circ - 500 \cos 30^\circ - 1000 \sin 30^\circ = -225.906 \text{ N} \quad (1)$$

The algebraic sum of vertical forces must be equal to the vertical component of the resultant, i.e.

$$1000 \sin 45^\circ = 500 \sin 30^\circ + 1000 \sin 30^\circ + F \sin \theta$$

$$F \sin \theta = 1000 \sin 45^\circ - 500 \sin 30^\circ - 1000 \cos 30^\circ = -762.472 \text{ N} \quad (2)$$

Solving from Eqs. (1) and (2), we get

$$F = 795.234 \text{ N and } \theta = \tan^{-1} \left(\frac{762.472}{225.906} \right) = 16.50^\circ$$

4. (a) (i) The first moment of area of a semicircular area about its diameter d is given by:

(A) $\frac{d^3}{12}$

- (ii) Centroid of a triangular area of base b and height h taken about an axis coincident with the base is given by: (D) $\frac{h}{3}$

- (iii) Moment of total area about its centroidal axis is: (C) zero
 (iv) Centroid conveys some clues about: (B) Centroid of a body
 (c) With respect to the co-ordinate axis x and y , locate the centroid of the area shown in Figure Q.4(c).

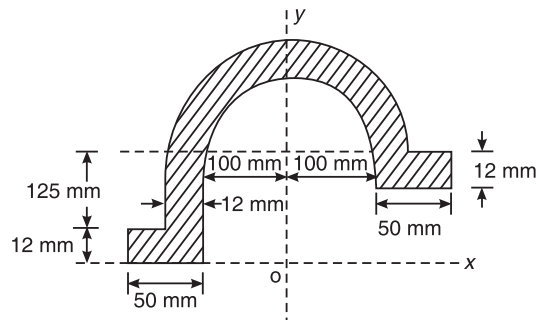

Figure Q.4(c)

| S.No. | Component | Area (mm ²) | x (mm) | y (mm) | ax | ay |
|------------|--------------|-------------------------|----------|----------|--------------------|---------------------|
| 1 | Rect-1 | 600.00 | -125.00 | -131.00 | -75,000.00 | 3,600.00 |
| 2 | Rect-2 | 1,500.00 | -106.00 | -62.50 | -159,000.00 | 111,750.00 |
| 3 | Rect-3 | 600.00 | 125.00 | 6.00 | 75,000.00 | 78,600.00 |
| 4 | Semicircle-4 | 19,704.07 | 0.00 | 47.53 | | 3,636,076.14 |
| 5 | Semicircle-5 | -15,707.96 | 0.00 | 42.44 | | -2,818,657.63 |
| Sum | | 6,696.11 | | | -159,000.00 | 1,011,368.50 |

$$\bar{x} = \frac{\sum ax}{\sum a} = \frac{-159000}{6696.11} = -23.75 \text{ mm} \quad \text{and} \quad \bar{y} = \frac{\sum ay}{\sum a} = \frac{101368.5}{6696.11} = 151.04 \text{ mm}$$

The centroid of the given Fig. w.r.t. given axes is $(-23.75, 151.04)$

PART B

5. (a) (i) The force that cancels the effects of the force system on the body is known as: (D) Equilibrant
 (ii) If the sum of all the forces acting on a body is zero it may be concluded that the body: (C) May be in equilibrium provided the forces are concurrent
 (iii) For a smooth spherical surface reaction acts: (C) Perpendicular to the plane of contact
 (iv) A system that possesses a resultant: (C) Will not be in equilibrium
 (c) Cylinder 'A' of diameter 200 mm and cylinder B of diameter 300 mm are placed in a trough as shown in Figure Q.5(c). If the cylinder A weighs 800 N and B weighs 1200 N, determine the reactions developed at contact surfaces P, Q, R and S. Assume all contact surfaces are smooth.

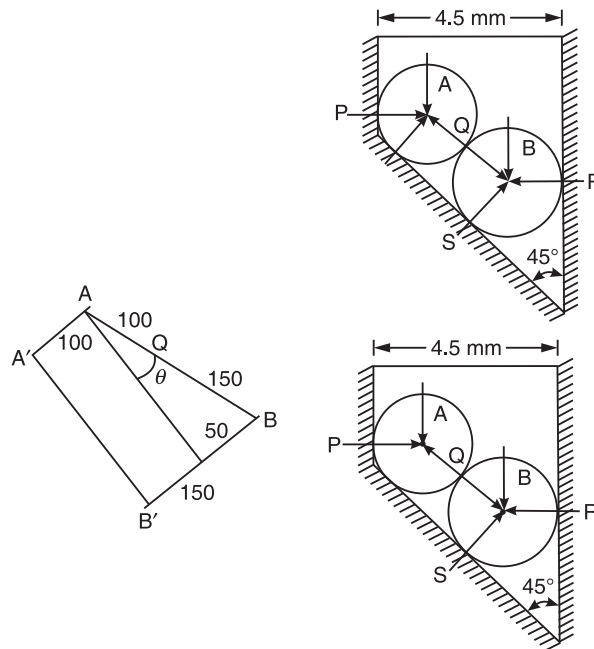

Figure Q.5(c)

As there are four forces acting on each sphere, it is not possible to solve the problem with three equilibrium equations. Hence it should be assumed that either the vertical wall is not in place or sphere A is not resting on the inclined side.

Let us assume that the sphere is not resting on the inclined side so that one reaction is zero and only R_P , R_Q and W are acting on sphere A.

Sphere A

$$\sin \theta = \frac{(150 - 100)}{(100 + 150)} = 11.54^\circ$$

Three forces are acting at A and the system is in equilibrium. By Lami's theorem, we get

$$\frac{800}{\sin(90 + 45 + 11.54)} = \frac{R_P}{\sin(180 - 45 - 11.54)} = \frac{R_Q}{\sin(90)}$$

$$R_P = 1210.5 \text{ N}$$

$$R_Q = 1450.97 \text{ N}$$

Sphere B

Four forces are acting at B and the system is in equilibrium. By the conditions of equilibrium, we get

Algebraic sum of horizontal components of all the forces is zero

$$R_S \sin 45^\circ + R_Q \sin (45 + 11.54) - R_R = 0$$

$$R_R - R_S \sin 45^\circ = 1450.97 \sin (45 + 11.54) = 1210.46 \text{ N} \quad (1)$$

Algebraic sum of vertical components of all the forces is zero

$$R_S \cos 45^\circ - R_Q \cos(45 + 11.54) - 1200 = 0$$

$$R_S \cos 45^\circ = 1450.97 \cos (45 + 11.31) + 1200 = 2000 \text{ N}$$

$$R_S = 2828.52 \text{ N}$$

Substituting for R_S in Eq. (1), we get

$$R_R = 2828.52 \sin 45 + 1210.46 = 3210.52 \text{ N}$$

| S.No. | R_P | R_Q | R_R | R_S |
|-----------|--------|---------|---------|---------|
| Force (N) | 1210.5 | 1450.97 | 3210.52 | 2828.52 |

6. (a) (i) Minimum number of members required to form a simple truss (B) 3
(ii) In the method of joints for the analysis of forces in the member of truss, the number of equilibrium equations available at each joint are: (B) 3
(iii) For a system of coplanar parallel forces to be in equilibrium: (C) Both resultant force and resultant couple must vanish
(iv) The beam is neither permitted to move in any direction nor allowed to rotate in the case of: (B) Fixed support
- (c) Determine the reactions at the support for the beam loaded as shown in Figure Q.6(c).

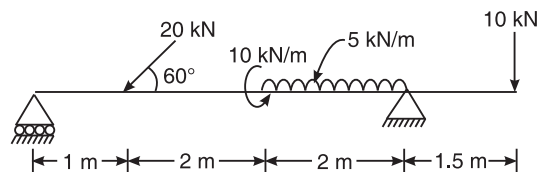

Figure Q.6(c)

Applying the equations of equilibrium,
Algebraic sum of vertical forces is zero.

$$H_B = 20 \cos 60 = 10 \text{ kN } (\rightarrow)$$

Algebraic sum of vertical forces is zero.

$$R_A + R_B = 20 \sin 60 + 5 \times 2 + 10 = 37.32 \text{ kN } (\uparrow) \quad (1)$$

Algebraic sum of moment of all the forces about A is zero

$$5R_B + 10 = 10 \times 6.5 + (5 \times 2) \left(3 + \frac{2}{2} \right) + (20 \sin 60) \times 1 \text{ or } R_B = 22.464 \text{ kN}$$

Algebraic sum of moment of all the forces about B is zero

$$5R_A + 10 \times 1.5 = 10 + (5 \times 2) \left(\frac{2}{2} \right) + (20 \sin 60) \times 4 \text{ or } R_A = 14.856 \text{ kN}$$

$$\text{Check: } R_A + R_B = 14.856 + 22.464 = 37.32 \text{ kN } (\uparrow)$$

480 SOLUTIONS TO THE EXAMINATION PAPERS OF VTU

7. (a) (i) A body of weight Q is placed on an inclined rough plane. The inclination of the plane with the horizontal is less than the angle of friction. The body will: (C) The body is in equilibrium
- (ii) The angle which an inclined surface makes with the horizontal when a body placed on its verge of moving down, is called: (A) Angle of repose
- (iii) If ϕ = angle of friction and μ = coefficient of friction, then which equation is valid: (A) $\tan \phi = \mu$
- (iv) Angle of friction is angle between: (B) The normal reaction and frictional force
- (c) A uniform ladder of 4 m rests against a vertical wall with which it makes an angle of 45° as shown in Figure Q.7(c). The coefficient of friction between the ladder and the floor is 0.5. If the man whose weigh is one-half of that of ladder ascends it, how high will he be when the ladder slips?

As the wall friction has not been defined let us assume $\mu_w = 0$ (smooth wall) $\mu_g = 0.5$

From the conditions of equilibrium, we have

Sum of all the horizontal components is zero, i.e. $\Sigma H = 0$

$$F_g = \mu_g N_g = N_w \quad (1)$$

Sum of all the vertical components is zero, i.e. $\Sigma V = 0$

$$N_g = W + \frac{W}{2} = \frac{3W}{2} \quad (2)$$

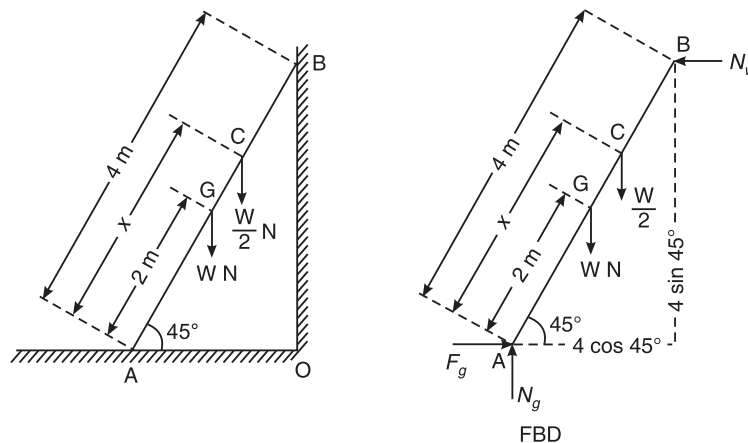

Figure Q.7(c)

Taking moments of all the components about A,

$$(N_w) (4 \sin 45^\circ) = (W) (2 \cos 45^\circ) + \left(\frac{W}{2}\right) (x \cos 45^\circ)$$

$$\therefore N_g = W + \frac{W}{2} = \frac{3W}{2}$$

From Eqs. (1) and (2)

$$F_g = 0.5 \times \frac{3W}{2} = 0.75 W = (0.5 + 1.125x) W$$

or $x = 2 \text{ m}$

8. (a) (i) The moment of inertia of a body is: (A) 0.2726 m^4
 (ii) The second moment of a plane area about any axis as compared to its second moment about the neutral axis: (A) is always more
 (iii) Moment of inertia of a square side a about an axis through its centre of gravity is:

(C) $\frac{a^4}{12}$

- (iv) The value of moment of inertia depends on: (D) Cross-sectional dimensions.

- (c) Determine the second moment of area about horizontal centroidal axis for the shaded area shown in Figure Q.8(c). Also find the radius of gyration about the same axis. Take $R_1 = 50 \text{ mm}$ and $R_2 = 20 \text{ mm}$.

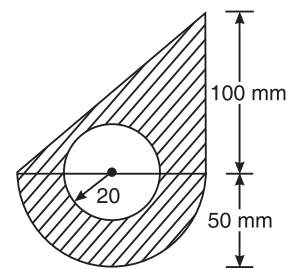

Figure Q.8(c)

| S.No. | Figure | Area (a) mm ² | Centroidal axis y mm | ay^2 mm ³ | ay^2 mm ⁴ | \bar{I}_x mm ⁴ |
|-------|--------------|---|--|---------------------------|---------------------------|---|
| 1 | Tri-1 | $\frac{1}{2} \times 100 \times 100$ = 5000 | $\frac{1}{3} \times 100$ = 33.33 | 166666.67 | 5,555,555.56 | $\frac{100 \times 100^3}{36}$ = 2,777,777.78 |
| 2 | Semicircle-2 | $\frac{\pi \times 50^2}{2}$ = 3926.99 | $\frac{4 \times 50}{3\pi}$ = -21.22 | -83333.33 | 1,768,388.26 | 0.11×50^4 = 687,500.00 |
| 3 | Circle-3 | $-\pi \times 20^2$ = -1256.637 | 0 | 0 | | $-\frac{\pi \times 20^4}{4}$ = -125,663.71 |
| Total | | 7670.353 | 466851.02 | 83333.33 | 7323943.812 | 3339614.07 |

$$\bar{y} = \frac{\sum ay}{\sum a} = \frac{83333.33}{7670.353} = 10.86 \text{ mm}$$

Moment of inertia about reference axis is given by

$$I_x = \sum \bar{I}_x + \sum ay^2 = 3,339,614.07 + 7,323,943.81 = 10,663,557.88 \text{ mm}^4$$

Moment of inertia on horizontal centroidal axis is given by

$$\bar{I}_x = I_x - (\sum a)\bar{y}^2 = 10,663,557.88 - (7,670.35)(10.86)^2 = 9,758,196.19 \text{ mm}^4$$

$$\text{Radius of gyration } k_x = \sqrt{\frac{\bar{I}_x}{A}} = \sqrt{\frac{9758196.19}{7670.35}} = 35.67 \text{ mm}$$

June/July 2011 Examination Paper

PART A

1. (a) (i) The topmost layer of the road over which the traffic moves is: (B) Wearing coat
 (ii) The branch of civil engineering which deals with planning scheduling and execution of project is: (C) Construction technology and management
 (iii) The bridges of span between 8 m and 30 m are: (A) Minor bridges
 (iv) Bituminous road is also known as: (A) Flexible pavement
2. (a) (i) Branch of mechanics which deals with the motion of bodies referring to the forces causing the motion is: (B) Kinematics
 (ii) Geometrical representation of moment of a force about a point is given by: (B) Twice the area of triangle
 (iii) A single force which can nullify the effect of system of forces is: (C) Equilibrant
 (iv) If a given force system can be replaced by another system with exactly same net effect as given system, the two systems are said to be: (A) Equivalent

- (b) Resolve 400 N acting on a block as shown in Figure Q.2(b) into two components as given below. (a) Horizontal and vertical components. (b) Along the inclined plane and at right angles to the plane.

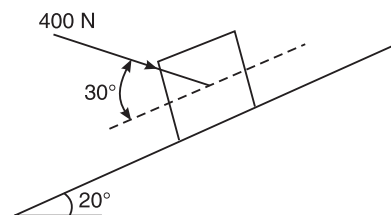

Figure Q.2(b)

- (a) Resolving 400 N force into horizontal and vertical directions we get

$$F_H = 400 \cos (30 - 20) = 393.92 \text{ N}$$

$$F_V = 400 \sin (30 - 20) = 69.41 \text{ N}$$

- (b) Resolving 400 N force along the plane and normal to the plane, we get

$$F_H = 400 \cos (30) = 346.41 \text{ N}$$

$$F_V = 400 \sin (30) = 200 \text{ N}$$

- (c) Determine the moment of force about "A" shown in Figure Q.2(c).

Resolving the force 5 kN into horizontal and vertical directions and taking moment about the point A, we get

$$M_o = (5 \cos 40^\circ) (3) + (5 \sin 40^\circ) (1) = 14.705 \text{ kNm}$$

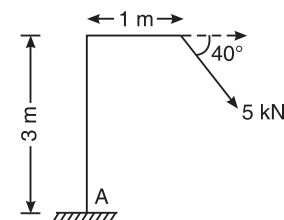

Figure Q.2(c)

3. (a) (i) Maximum and minimum resultant of two concurrent forces 20kN and 12kN are: (B) 32 and 8 kN
 (ii) A couple consists of: (A) two equal parallel and opposite forces separated by a distance
 (iii) Resultant of two unlike parallel forces 10 kN and 15 kN is: (B) 5 kN
 (iv) Varignon's theorem is applicable to: (C) only non-concurrent systems

- (b) A dam section is shown in Figure Q.3(b). Determine the magnitude, direction and position of resultant with respect to "O".

The net forces acting along x axis is

$$F_x = 5 - 3 \sin 60 = 2.402 \text{ kN } (\rightarrow)$$

$$F_y = 12 + 3 \cos 60 = 13.5 \text{ kN } (\downarrow)$$

$$R = \sqrt{2.402^2 + 13.5^2} = 13.712 \text{ kN}$$

$$\tan(\theta) = \frac{13.5}{2.402}$$

or $\theta = 44.55^\circ$

The moment of all the components about O

$$M_o = 13.5x = 3 \times 1 + 12 \times 4 - 5 \times 2 = 41 \text{ kNm}$$

or $x = 3.037 \text{ m from O}$

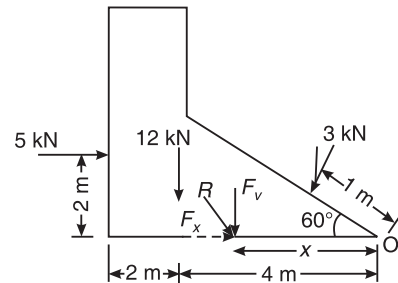

Figure Q.3(b)

- (c) 2 kN force is the resultant of system of forces acting up along y -axis as shown in Figure Q.3(c). Determine the value of F and θ .

The resultant force is acting only along y axis and hence the net forces acting along x direction is zero.

$$F \cos \theta + 2.4 \cos(30) - 5 = 0$$

$$F \cos \theta = 2.92 \text{ kN } (\rightarrow) \quad (1)$$

The net forces acting along y direction is 2 kN.

$$F \sin \theta - 2.4 \sin(30) = 2$$

$$F \sin \theta = 3.2 \text{ kN } (\uparrow) \quad (2)$$

Solving Eqs. (1) and (2), we get,

$$\tan \theta = 1.095 \text{ or } \theta = 47.605^\circ$$

and

$$F = 4.333 \text{ kN}$$

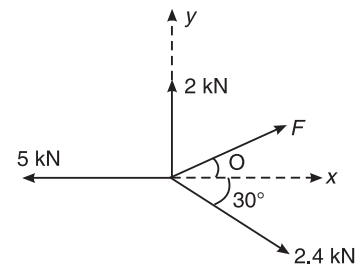

Figure Q.3(c)

4. (a) (i) Centroid of lamina must be: (C) not necessarily within a lamina.
(ii) Centroid of a sector which is symmetrical about horizontal axis is given by:

$$(A) \frac{2R}{3\alpha} \sin \alpha$$

- (iii) The centroid of lamina is determined by the principle of: (B) Varignon's theorem.

- (iv) One of the coordinates of centroid of a lamina symmetrical about vertical axis with a width of 200 mm and depth 150 mm is: (A) 100 mm.

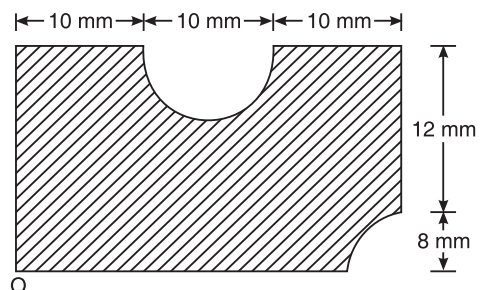

Figure Q.4(b)

484 SOLUTIONS TO THE EXAMINATION PAPERS OF VTU

(b) Determine the centre of gravity of the lamina shown in Figure Q.4(b) with respect to O.

| S.No. | Name of Figure | Area | Centroidal Ordinates | | ax | ay |
|---------|----------------|---------------------------------------|---------------------------------------|---|---------|----------|
| | | a mm ² | x mm | y mm | | |
| 1. | Rect-1 | $30 \times 20 = 600$ | $30/2 = 15$ | $20/2 = 10$ | 9000 | 6000 |
| 2. | Quad-2 | $-\frac{\pi \times 8^2}{4} = -50.265$ | $30 - \frac{4 \times 8}{3\pi} = 26.6$ | $\frac{4 \times 8}{3\pi} = 3.395$ | -1337.3 | -170.65 |
| 3. | Semi-circle-3 | $-\frac{\pi \times 5^2}{2} = -39.27$ | $10 + \frac{10}{2} = 15$ | $20 - \frac{4 \times 5}{3\pi} = 17.878$ | -589.05 | -702.066 |
| Total = | | 510.465 | | | 7073.65 | 5127.27 |

$$\bar{x} = \frac{7073.65}{510.465} = 13.86 \text{ mm} \quad \text{and} \quad \bar{y} = \frac{5127.27}{510.465} = 10.04 \text{ mm}$$

The centroid of the given Fig. w.r.t. O is (13.86,10.04)

PART B

5. (a) (i) Lami's theorem is applicable for: (A) Coplanar concurrent forces
(ii) Forces in equilibrium produce: (C) Zero resultant
(iii) A body lies in equilibrium under the action of three forces when: (A) Resultant of any two forces is equal, opposite and collinear with third force
(iv) The reaction at the surface of contact of a sphere is: (B) normal to the surface of contact
- (b) Determine the forces in the wires shown in Figure Q.5(c).

Joint B

Three forces are acting at B and the system is in equilibrium. By Lami's theorem, we get

$$\frac{300}{\sin(40 + 60)} = \frac{F_{BA}}{\sin(180 - 60)} = \frac{F_{BE}}{\sin(180 - 40)}$$

$$F_{BA} = 263.816 \text{ N}$$

$$F_{BE} = 195.811 \text{ N}$$

Joint A

Four forces are acting at A and the system is in equilibrium. From the equations of equilibrium, Algebraic sum of horizontal and vertical components are zero.

$$F_x = 0 = F_{AB} \sin 40^\circ + F_{AD} \cos 30^\circ - F_{AC}$$

$$F_{AC} = 263.816 \times \sin 40^\circ + F_{AD} \cos 30^\circ = 169.578 + 0.866 F_{AD}$$

$$F_y = 0 = F_{AD} \sin 30^\circ - F_{AB} \cos 40^\circ - 200$$

$$F_{AD} = 200 + 263.816 \cos 40^\circ = 402.09 \text{ N}$$

Substituting in Eq. (1), we get

$$F_{AC} = 517.798 \text{ N}$$

| S.No. | AC | AD | BA | BE |
|-----------|---------|--------|---------|---------|
| Force (N) | 517.798 | 402.09 | 263.816 | 195.811 |

- (c) A sphere of weight 300 N rests on an incline as shown in Figure Q.5(c). Determine the surface reactions.

Three forces are acting at O and the system is in equilibrium. By Lami's theorem, we get

$$\frac{300}{\sin(90 + 30)} = \frac{F_W}{\sin(180 - 30)} = \frac{F_N}{\sin(90)}$$

Reaction of wall = $F_W = 173.205 \text{ N}$

Normal Reaction = $F_N = 346.41 \text{ N}$

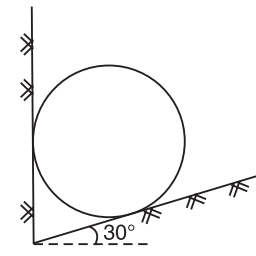

Figure Q.5(c)

6. (a) (i) A beam supported by roller and hinge supports subjected to only vertical loads has: (B) Two vertical reactions
(ii) A determinate beam can be analyzed by applying maximum: (B) three conditions of equilibrium
(iii) Water in a tank is an example of: (B) udl
(iv) A cantilever beam is one: (D) whose one end is fixed and the other end is free
- (c) Determine the support reactions for the beam shown in Figure Q.6(c).

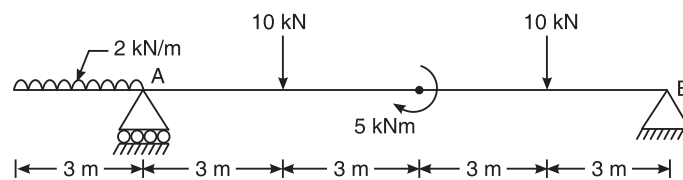

Figure Q.6(c)

Applying the equations of equilibrium, Algebraic sum of vertical forces is zero.

$$R_A + R_B = 2 \times 3 + 10 + 10 = 26 \text{ kN} (\uparrow) \quad (1)$$

Algebraic sum of moment of all the forces about A is zero

$$12R_B + (2 \times 3) \left(\frac{3}{2} \right) = 10 \times 3 + 10 \times 9 + 5$$

or $R_B = 9.67 \text{ kN}$

Algebraic sum of moment of all the forces about B is zero

$$12R_A + 5 = (2 \times 3) \left(12 + \frac{3}{2} \right) + 10 \times 9 + 10 \times 9$$

or $R_A = 16.33 \text{ kN}$

Check: $R_A + R_B = 16.67 + 9.67 = 26 \text{ kN} (\uparrow)$

486 SOLUTIONS TO THE EXAMINATION PAPERS OF VTU

- (d) Two men A & B carry a stone block weighing 2 kN, suspending the stone on a horizontal beam and carrying it on their shoulders at each end. The beam is 2 m long and is of weight 580 N/m. A can carry maximum of weight of 1.2 kN and B can carry a weight of 0.9 kN. Determine the distance at which the stone block is suspended from the end carried by A. The reactions acting vertically upwards at the two ends of the beam A and B are 1.2 kN and 0.9 kN and the total is 2.1 kN.

The total vertical forces acting downwards is the weight of the stone 2 kN and weight of the beam $0.58 \times 2 = 1.16$ kN, the total of which is 3.16 kN.

As the system is not in equilibrium, the problem is wrong.

7. (a) (i) The force of friction is independent of: (D) None of these
 (ii) The body remains at rest as long as the friction force is: (A) Equal to the force applied OR (C) Less than the force applied
 (iii) Static friction is the friction between two surfaces: (A) when no lubrication is used
 (iv) Ratio of limiting force of friction to the normal reaction is: (B) coefficient of friction
- (c) A uniform ladder of weight 850 N and of length 6 m rests on a horizontal ground and leans against a smooth vertical wall. The angle made by the ladder with the horizontal is 65° . When a man of weight 700 N stands on the ladder at a distance of 4 m from the top of the ladder, the ladder is at the point of sliding. Determine the coefficient of friction between the ladder and the floor.

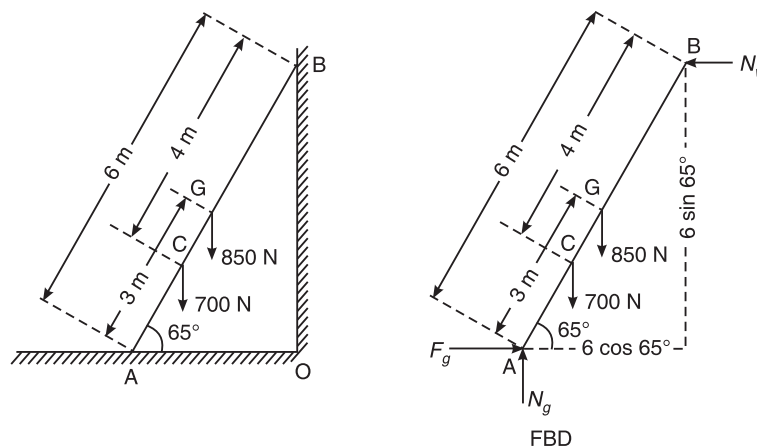

Figure Q.7(c)

$$\mu_w = 0 \text{ (smooth wall)}$$

From the conditions of equilibrium, we have

Sum of all the horizontal components is zero. i.e. $\Sigma H = 0$

$$F_g = \mu_g N_g = N_w \quad (1)$$

Sum of all the vertical components is zero, i.e. $\Sigma V = 0$

$$N_g = 850 + 700 = 1550 \quad (2)$$

Taking moments of all the components about A,

$$(N_w)(6 \sin 65^\circ) = (850)(3 \cos 65^\circ) + (700)(2 \cos 65^\circ)$$

$$\therefore N_w = 306.986 \text{ N}$$

From Eq. (1),

$$F_g = 306.986 \text{ N}$$

But

$$F_g = \mu_g N_g = \mu_g \times 1550 = 306.986$$

Hence,

$$\mu_g = 0.198$$

8. (a) (i) M.I. of an annular area with outer radius 0.8 m and inner radius 0.5 m is: (A) 0.2726 m⁴
(ii) The distance at which an area can be imagined to be placed and squeezed so that there is no change in moment of inertia is known as: (A) Radius of gyration
(iii) Moment of inertia is: (D) None of the above
(iv) M.I. of a rectangle about the base is: (B) $\frac{bd^3}{3}$
- (c) Determine M.I. about horizontal centroidal axis for the shaded area shown in Figure Q.8(c). Also find the radius of gyration about the same axis. Even though M.I. is required on only on x axis, the solution gives on y axis also.

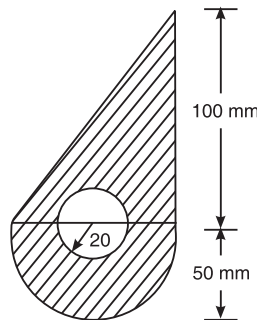

Figure Q.8(c)

| S.No. | Figure | Area | Centroidal axis | | ax | ay |
|-------|--------------|---|-------------------------------------|---|------------|-----------|
| | | a mm ² | x mm | y mm | | |
| 1 | Tri-1 | $\frac{1}{2} \times 100 \times 100$ = 5000 | $\frac{2}{3} \times 100$ = 66.67 | $\frac{1}{3} \times 100$ = 33.33 | 333333.33 | 166666.67 |
| 2 | Semicircle-2 | $\frac{\pi \times 50^2}{2}$ = 3926.99 | 50 | $-\frac{4 \times 50}{3\pi}$ = -21.22 | 196349.54 | -83333.33 |
| 3 | Circle-3 | $-\pi \times 20^2$ -1256.637 | 50 | 0 | -62831.853 | 0 |
| Total | | 7670.353 | | | 466851.02 | 83333.33 |

488 SOLUTIONS TO THE EXAMINATION PAPERS OF VTU

$$\bar{x} = \frac{\sum ax}{\sum a} = \frac{466851.02}{7670.353} = 60.864 \text{ mm} \quad \text{and} \quad \bar{y} = \frac{\sum ay}{\sum a} = \frac{83333.33}{7670.353} = 10.86 \text{ mm}$$

| S.No. | Figure | ax^2 mm ² | ay^2 mm ² | Moment of inertia | |
|-------|--------------|---------------------------|---------------------------|--|--|
| | | | | \bar{I}_x mm ⁴ | \bar{I}_y mm ⁴ |
| 1 | Tri-1 | 22,222,222.22 | 5,555,555.56 | $\frac{10 \times 100^3}{36}$ = 2,777,777.78 | $\frac{10 \times 100^3}{36}$ = 2,777,777.78 |
| 2 | Semicircle-2 | 9,817,477.04 | 1,768,388.26 | 0.11×50^4 = 687,500.00 | $\frac{\pi \times 50^4}{8}$ = 2,454,369.26 |
| 3 | Circle-3 | -3,141,592.65 | | $-\frac{\pi \times 20^4}{4}$ = -125,663.71 | $-\frac{\pi \times 20^4}{4}$ = -125,663.71 |
| Total | | 28898106.61 | 7323943.812 | 3339614.07 | 5106483.33 |

$$\text{Reference axis } I_x = 3,339,614.07 + 7,323,943.81 = \mathbf{10,663,557.88 \text{ mm}^4}$$

$$\text{Reference axis } I_y = 5,106,483.33 + 28,898,106.61 = \mathbf{34,004,589.94 \text{ mm}^4}$$

Moment of Inertia on centroidal axes

$$\bar{I}_x = 10,663,557.88 - (7,670.35)(10.86^2) = \mathbf{9,758,196.19 \text{ mm}^4}$$

$$\bar{I}_y = 34,004,589.94 - (7,670.35)(60.864^2) = \mathbf{5,590,010.53 \text{ mm}^4}$$

Polar Moment of Inertia $\bar{I}_z = 9,758,196.19 + 5,590,010.53$

$$= \mathbf{15,348,206.72 \text{ mm}^4}$$

$$\text{Radius of gyration } k_x = \sqrt{\frac{\bar{I}_x}{A}} = \sqrt{\frac{9758196.19}{7670.35}} = \mathbf{35.67 \text{ mm}}$$

$$\text{Radius of gyration } k_y = \sqrt{\frac{\bar{I}_y}{A}} = \sqrt{\frac{5590010.53}{7670.35}} = \mathbf{27.00 \text{ mm}}$$

January 2011 Examination Paper

PART A

1. (a) (i) Geotechnical engineering involves the study of: (B) Soil
 (ii) Shoulders are the components of: (A) Roads
 (iii) A bridge constructed at some angle to the river flow is: (A) Skew Bridge
 (iv) A bascule bridge is a: (D) Movable Bridge
2. (a) (i) Effect of a force on a body depends on: (D) All of these
 (ii) When trying to turn a key into a lock, following is applied: (D) Couple
 (iii) A single force and a couple acting in the same plane upon a rigid body: (B) Cannot balance each other
 (iv) Moment of a force: (D) measures the ability to produce turning about axes

- (d) Determine the angle α for which the moment of the 500 N force shown in Figure Q.2(d) is maximum about O. Also find the maximum moment.

Resolving 500 N force in x and y directions and taking moment about the point O, we get

$$\begin{aligned} M_o &= (500 \sin \alpha) (150 \cos 20^\circ) \\ &\quad + (500 \cos \alpha) (100 + 150 \sin 20^\circ) \\ &= 70476.95 \sin \alpha + 75651.51 \cos \alpha \end{aligned}$$

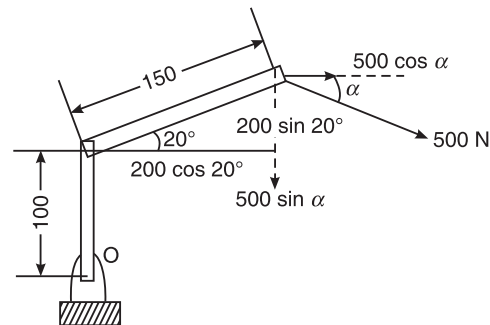

Figure Q.2(d)

Maximising the moment about O, with respect to α , differentiating the above expression w.r.t. α and equating it to zero, we get

$$\frac{dM_o}{d\alpha} = 70476.95 \cos \alpha - 75651.51 \sin \alpha = 0$$

or
$$\tan \alpha = \frac{70476.95}{75651.51} \text{ or } \alpha = 42.97^\circ$$

$$M_o = 103393.19 \text{ Nm}$$

3. (a) (i) Two forces each equal to $P/2$ act at right angles. Their effect may be neutralized by the third force, acting along their bisector in the opposite direction, with a magnitude of: (D) $\frac{P}{\sqrt{2}}$.
 (ii) In a coplanar concurrent forces system, if $\Sigma V = 0$, then the resultant is: (A) Horizontal
 (iii) The Varignon's theorem is not applicable for the forces, which are: (B) Non-coplanar and non-concurrent
 (iv) The magnitude of the resultant of two forces of magnitudes P and $\sqrt{2}P$ is P . Then the angle between the two forces is: (C) 45°

490 SOLUTIONS TO THE EXAMINATION PAPERS OF VTU

- (b) The sum of two concurrent forces P and Q is 500 N and their resultant is 400 N. If the resultant is perpendicular to P find P , Q and the angle between P and Q .

$$P + Q = 500 \quad (1)$$

$$P^2 + Q^2 + 2PQ \cos \theta = 160000 \quad (2)$$

Squaring Eq. (1), we get

$$P^2 + Q^2 + 2PQ = 250000$$

$$\tan 90^\circ = \frac{Q \sin \theta}{P + Q \cos \theta} = \frac{1}{0}$$

This is possible only when

$$P + Q \cos \theta = 0$$

or

$$P = -Q \cos \theta$$

$$P^2 + Q^2 - 2P^2 = 160000$$

\Rightarrow

$$Q^2 - P^2$$

$$(Q + P)(Q - P) = 160000$$

But

$$P + Q = 500,$$

then

$$Q - P = 320 \quad (3)$$

Adding Eqs. (1) and (3), we get

$$2Q = 820 \quad \text{or} \quad Q = 410 \text{ N}$$

and

$$P = 90 \text{ N}$$

$$\theta = 102.68^\circ$$

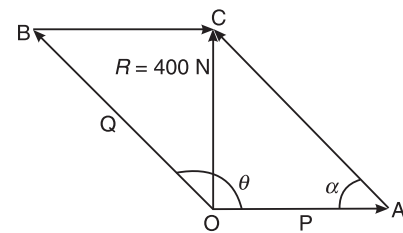

- (c) The forces acting on 1m length of a dam are shown in Figure Q.3(c). Determine the resultant force acting on the dam. Calculate the point of intersection of the resultant with the base.

The net forces acting along x axis is

$$F_x = 50 - 30 \cos 30 = 24.02 \text{ kN} (\rightarrow)$$

The net forces acting along y axis is

$$F_y = -120 - 30 \sin 30 = 135 \text{ kN} (\downarrow)$$

The resultant is given by

$$R = \sqrt{24.02^2 + 135^2} = 137.12 \text{ kN}$$

or $\theta = 79.91^\circ \curvearrowright$

Taking moments about C, we have

$$50 \times 2 - 120(6 - 2) - 30 \times 1.25 = 135x$$

$$x = -3.09 \text{ m}$$

The resultant is located at 3.09 m from toe (C); or 2.91 m from heel (O)

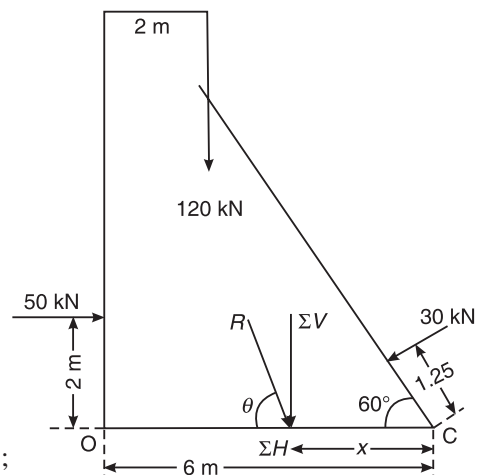

Figure Q.3(c)

4. (a) (i) The centre of gravity of a plane lamina will not be its geometrical centre if it is a:
(C) Right angled triangle
- (ii) The centroid of an equilateral triangle of side a is: (C) $\frac{a}{2\sqrt{3}}$
- (iii) The centroid of a semicircle of radius r with respect to its base is: (C) $\frac{4r}{3\pi}$
- (iv) Moment of the total area about its centroid is: (C) zero.
- (c) Find the centroid of the shaded area shown in Figure Q.4(c), obtained by cutting a semicircle of diameter 100 mm from the quadrant of a circle of radius 100 mm.

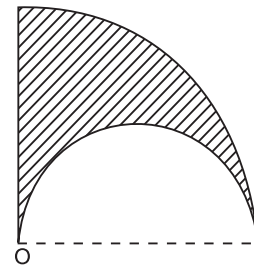

Figure Q.4(c)

$$\bar{x} = \frac{\Sigma ax}{\Sigma a} = \frac{136983.79}{3926.99} = 34.88 \text{ mm}$$

and

$$\bar{y} = \frac{\Sigma ay}{\Sigma a} = \frac{250000}{3926.99} = 63.66 \text{ mm}$$

| S.No. | Component | Area (mm ²) | x (mm) | y (mm) | ax | ay |
|-------|--------------|-------------------------|--------|--------|-------------------|-------------------|
| 1 | Quad-1 | 7,853.98 | 42.44 | 42.44 | 333,333.33 | 333,333.33 |
| 2 | Semicircle-2 | -3,926.99 | 50.00 | 21.22 | -196,349.54 | -83,333.33 |
| | Sum | 3,926.99 | | | 136,983.79 | 250,000.00 |

PART B

5. (a) (i) A free body diagram is a diagram: (D) drawn
- (ii) A particle acted upon by two forces of equal magnitude is in equilibrium. The angle between the forces is: (A) 0°
- (iii) If a body is in equilibrium, then it is concluded that: (D) Both (B) and (C).
- (iv) Three forces of magnitudes $F_1 = 100 \text{ N}$, $F_2 = 100 \text{ N}$ and $F_3 = 100\sqrt{3} \text{ N}$ act on a particle in a plane. The particle remains in equilibrium, only if the angle between F_1 and F_2 is: (C) 60°
- (b) A 3 kN crate is to be supported by a rope and pulley arrangements shown in Figure Q.5(b). Determine the magnitude and direction of the force F , which should be exerted at the free end of the rope.
- The problem cannot be solved with the given data. It should have been the least force F , when it makes an angle 90° with the rope, the problem can be solved.
- Consider the FBD of the system.

$$\tan \theta = \frac{3.6}{1.05} = 73.74^\circ$$

$$\alpha = 180 - 90 - 73.74 = 16.26^\circ$$

492 SOLUTIONS TO THE EXAMINATION PAPERS OF VTU

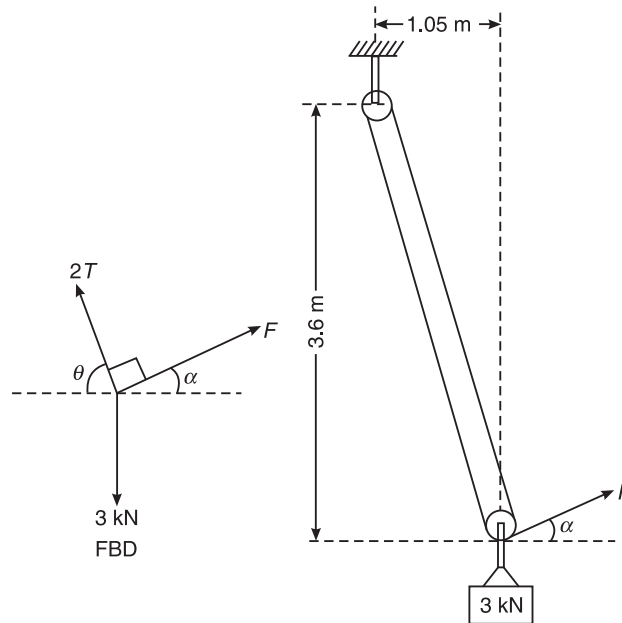

Figure Q.5(b)

Three forces are acting away from point and the system is in equilibrium, and hence, from Lami's theorem we get

$$\frac{3}{\sin 90^\circ} = \frac{F}{\sin(90 + \theta)^\circ} = \frac{2T}{\sin(90 + \alpha)^\circ}$$

$$3 = \frac{F}{\cos 73.74^\circ} = \frac{2T}{\cos 16.26^\circ}$$

$$T = 1.44 \text{ kN}$$

$$F = 0.84 \text{ kN}$$

- (c) Two rollers of weights **P** and **Q** are connected by a flexible string DE and rest on two mutually perpendicular planes AB and BC as shown in Figure Q.5(c). Find the tension (T) in the string and angle **f**, that it makes, with the horizontal, when the system is in equilibrium. Given **P** = 600 N, **Q** = 1000 N, **a** = 30°. Assume that the string is inextensible and passes freely through the slots in the smooth inclined planes AB and BC.

Consider the FBD of the system as shown.

As three forces are acting away from a point and the system is in equilibrium, Lami's theorem can be applied at E.

$$\frac{1000}{\sin(90 + (30 + \phi))} = \frac{N_1}{\sin(90 - \phi)} = \frac{T}{\sin(180 - 30)}$$

or

$$T = \frac{500}{\cos(30 + \phi)}$$

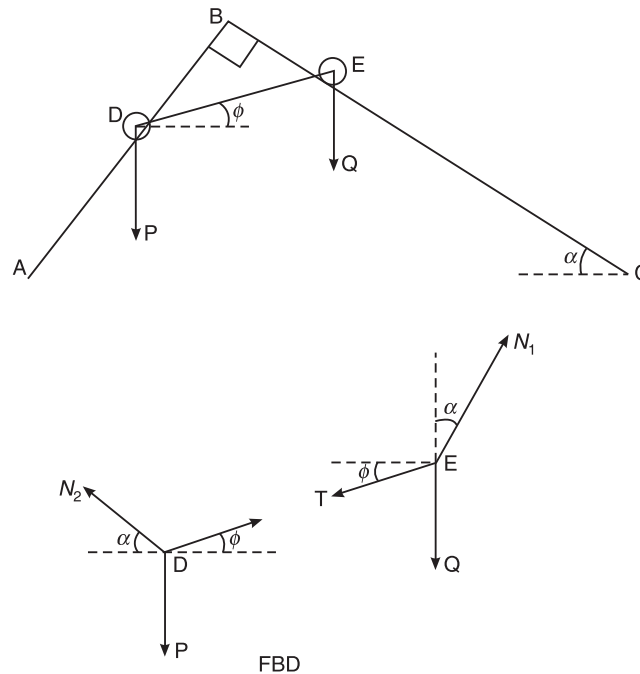

Figure Q.5(c)

Similarly, three forces are acting away from a point and the system is in equilibrium, Lami's theorem can be applied at D.

$$\frac{600}{\sin(180 - (30 + \phi))} = \frac{N_2}{\sin(90 + \phi)} = \frac{T}{\sin(90 + 30)}$$

$$\frac{500}{\cos(30) \cos(30 + \phi)} = \frac{600}{\sin(30 + \phi)}$$

$$\text{or } \frac{\sin(30 + \phi)}{\cos(30 + \phi)} = \tan(30 + \phi) = \frac{600 \cos(30)}{500} = 1.039$$

$$\text{or } 30 + \phi = 46.10^\circ$$

$$\text{or } \phi = 16.10^\circ$$

$$T = \frac{500}{\cos(30 + 16.10)} = 721.11 \text{ N}$$

6. (a) (i) Fixed beams have: (B) both ends fixed
(ii) GVL stands for: (C) Gradually Varying Load
(iii) A truss is perfect when: (A) $m = 2j - 3$
(iv) The minimum number of members to form a perfect truss is: (C) 3
- (b) Determine the reactions at the supports A and B, for the beam shown in Figure Q.6(b).

494 SOLUTIONS TO THE EXAMINATION PAPERS OF VTU

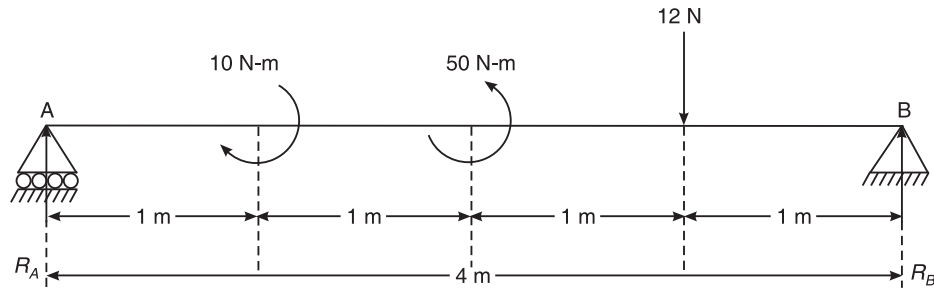

Figure Q.6(b)

From the conditions of equilibrium, we have

Sum of all the horizontal components is zero, i.e. $\Sigma H = 0$

$$H_B = 0$$

Sum of all the vertical components is zero, i.e. $\Sigma V = 0$

$$R_A + R_B = 12 \text{ kN } (\uparrow) \quad (1)$$

Taking moments of all the components about A,

$$4R_B + 50 = 12 \times 3 + 10$$

$$R_B = -1 \text{ kN} = 1 \text{ kN } (\downarrow)$$

Taking moments of all the components about B,

$$4R_A + 10 = 12 \times 1 + 50$$

$$R_A = 13 \text{ kN } (\uparrow)$$

Substituting in Eq. (1), we get, $13 - 1 = 12 \text{ kN}$, and hence O.K.

- (c) Find the support reactions and member forces for the pin-jointed truss shown in Figure Q.6(c), by method of joints.

From the conditions of equilibrium, we have
sum of all the horizontal components is zero,
i.e. $\Sigma H = 0$

$$H_A = 120 \text{ N } (\leftarrow)$$

Sum of all the vertical components is zero,
i.e. $\Sigma V = 0$

$$V_A + R_B = 100 \text{ N } (\uparrow) \quad (1)$$

Taking moments of all the components about A,

$$3R_B = 120 \times 4 = 480$$

or $R_B = 160 \text{ kN } (\uparrow)$

Taking moments about B,

$$3V_A + 120 \times 4 = 100 \times 3$$

$$V_A = -60 \text{ kN} = 60 \text{ kN } (\downarrow)$$

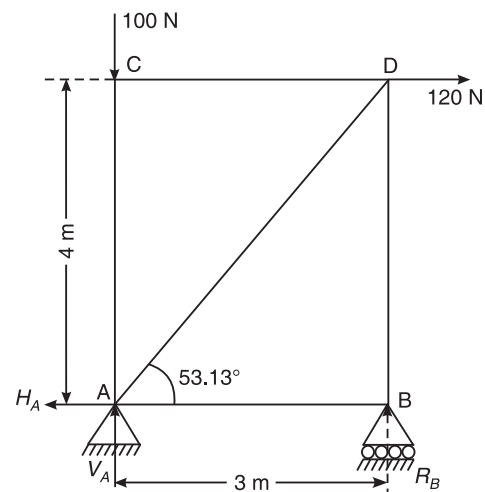

Figure Q.6(c)

Substituting in Eq. (1), we get,

$$160 - 60 = 100 \text{ kN, and}$$

hence O.K.

$$\theta = \tan^{-1}\left(\frac{4}{3}\right) = 53.13^\circ$$

Starting from the least number of unknowns, consider joint B

From the conditions of equilibrium, we have sum of all the horizontal components is zero, i.e. $\Sigma H = 0$

$$F_{BA} = 0$$

Sum of all the vertical components is zero, i.e. $\Sigma V = 0$

$$F_{BD} = R_B = 160 \text{ N (Compressive)}$$

Consider Joint D

From the conditions of equilibrium, we have sum of all the horizontal components is zero, i.e. $\Sigma H = 0$

$$F_{CD} = 120 + F_{AD} \cos 53.13^\circ \quad (1)$$

Sum of all the vertical components is zero, i.e. $\Sigma V = 0$

$$-F_{AD} \sin 53.13^\circ - F_{BD} = 0$$

or

$$F_{AD} = -200 \text{ kN} = 200 \text{ kN (Compressive)}$$

Consider Joint C

From the conditions of equilibrium, we have sum of all the horizontal components is zero, i.e. $\Sigma H = 0$

$$F_{CD} = 0$$

Sum of all the vertical components is zero, i.e. $\Sigma V = 0$

$$F_{AC} = 100 \text{ N}$$

Check

Consider Joint A

From the conditions of equilibrium, we have sum of all the horizontal components is zero, i.e. $\Sigma H = 0$

$$F_{AB} + F_{AD} \cos 53.13^\circ = 120$$

or

$$F_{AB} = 0$$

Sum of all the vertical components is zero, i.e. $\Sigma V = 0$

$$V_A + F_{AC} - F_{AD} \sin 53.13^\circ = 0$$

or

$$F_{AC} = 200 \sin 53.13^\circ - 60 = 100 \text{ N (Compressive)}$$

Hence O.K.

The resultant stresses in the members are:

| Member | AB | AC | AD | BD | CD |
|--------|---------|-------------|-------------|-------------|---------|
| Force | 0 | 100 N | 200 N | 160 N | 0 |
| Nature | Tensile | Compressive | Compressive | Compressive | Tensile |

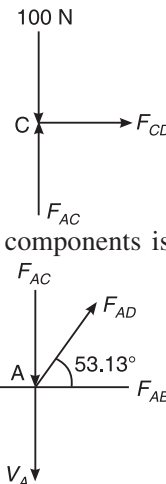
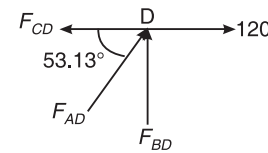
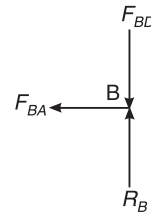

496 SOLUTIONS TO THE EXAMINATION PAPERS OF VTU

7. (a) (i) The angle which an inclined surface makes with the horizontal, when the body placed on it is on the point of moving down, is known as: (D) Angle of repose
(ii) If the angle of friction is zero, a body will experience: (C) the force of friction normal to the plane
(iii) The coefficient of friction depends on: (A) None of the above (options are wrong)
(iv) The tangent of the angle of friction is of: (B) Coefficient of friction
- (b) (ii) Determine the value of θ for impending motion of the blocks. Take coefficient of friction (μ) for all contact surfaces as 0.25 [Refer Figure Q.7(b)(ii)].

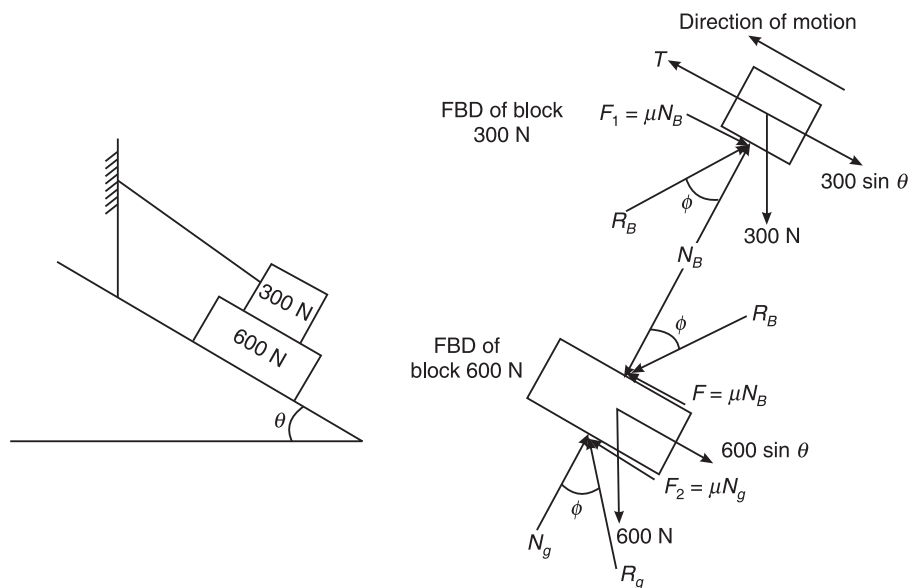

Figure Q.7(b) (ii)

$$\mu = 0.25$$

Consider the equilibrium of the 300 N block

System is in equilibrium. Algebraic sum of force components acting parallel to the plane must be zero

Resolving forces parallel to the plane,

$$T = 300 \sin \theta + \mu N_B = 300 \sin \theta + 0.25 N_B \quad (1)$$

Algebraic sum of force components acting perpendicular to the plane must be zero

Resolving forces perpendicular to the plane,

$$N_B = 300 \cos \theta$$

Substituting in Eq. (1),

$$T = 300 \sin \theta + 0.25 \times 300 \cos \theta = 300 \sin \theta + 75 \cos \theta \quad (2)$$

Consider the equilibrium of 600 N block.

Algebraic sum of force components acting parallel to the plane must be zero
Resolving forces parallel to the plane,

$$600 \sin \theta = \mu N_g + \mu N_B = 0.25 N_g + 0.25 N_B = 0.25 N_g + 75 \cos \theta \quad (3)$$

Algebraic sum of force components acting perpendicular to the plane must be zero
Resolving forces perpendicular to the plane,

$$N_g = N_B + 600 \cos \theta = 300 \cos \theta + 600 \cos \theta = 900 \cos \theta \quad (4)$$

Substituting in Eq. (3),

$$600 \sin \theta = 0.25 \times 900 \cos \theta + 75 \cos \theta = 300 \cos \theta$$

$$\tan \theta = 0.5$$

or

$$\theta = 26.565^\circ$$

- (c) The ladder shown in Figure Q.7(c), is 4 m long and is supported by a horizontal floor and vertical wall. The coefficient of friction at the wall is 0.25 and at the floor is 0.50. The weight of the ladder is 200 N, considered concentrated at G. The ladder supports a vertical load of 1000 N at C. Determine the reactions at A and B and compute the least value of α at which the ladder may be placed without slipping.

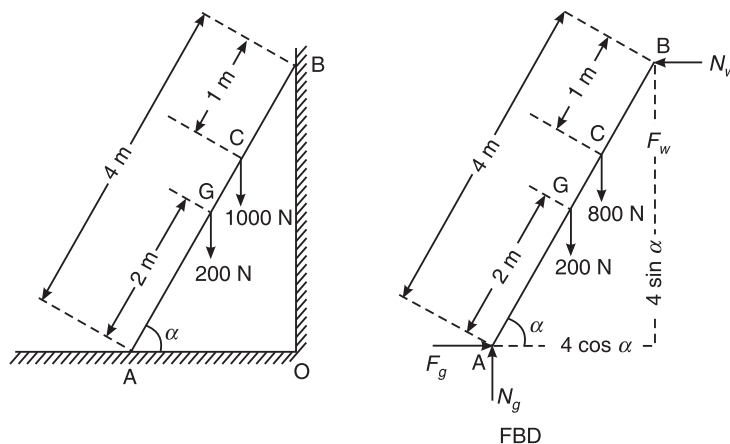

Figure Q.7(c)

From the conditions of equilibrium, we have

Sum of all the horizontal components is zero, i.e. $\Sigma H = 0$

$$F_g = \mu_g N_g = N_w \quad (1)$$

Sum of all the vertical components is zero, i.e. $\Sigma V = 0$

$$N_g + F_w = N_g + \mu_w N_w = 200 + 1000 = 1200 \quad (2)$$

Taking moments of all the components about A,

$$(N_w) (4 \sin \alpha) + (0.2 N_w) (4 \cos \alpha) = (200) (2 \cos \alpha) + (1000) (3 \cos \alpha)$$

498 SOLUTIONS TO THE EXAMINATION PAPERS OF VTU

$$\begin{aligned}\therefore N_w &= 331.25 \text{ N} \\ F_w &= \mu_w N_w = 0.2 \times 331.25 = 66.25 \text{ N}\end{aligned}$$

From Eq. (2), we have

$$N_g = 1000 - 66.25 = 933.75 \text{ N}$$

From Eq. (1), we have

$$331.25 = \mu_g \times 933.75$$

or

$$\mu_g = 0.355$$

8. (a) (i) The ratio of moment of inertia for triangle (bxh) coinciding with its base to a centroidal axis parallel to the base is (Given options are wrong): Answer is 3.
- (ii) The radius of gyration of a circular area of radius r is: (A) $\frac{r}{2}$
- (iii) The unit of moment of inertia of an area is: (D) m^4
- (iv) If I_G is the moment of inertia of a rectangle about its centroidal axis and I_{AB} is the moment of inertia about its base, then: (B) $I_G < I_{AB}$
- (c) Determine the radius of gyration about the centroidal axes for the lamina shown in Figure Q.8(c). All dimensions are in mm.

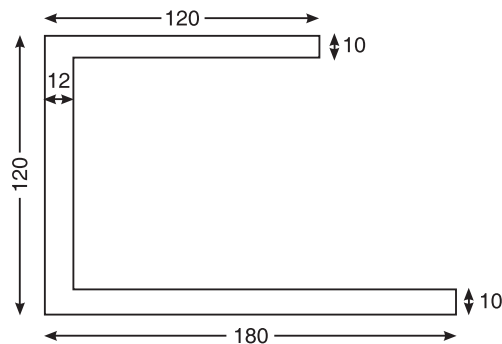

Figure Q.8(c)

| S.No. | Comp | Area (mm ²) | x (mm) | y (mm ²) | ax | ay | ax ² (mm ⁴) | ay ² (mm ⁴) | \bar{I}_x | \bar{I}_y |
|-------|--------|----------------------------|-----------|-------------------------|----------|---------|---------------------------------------|---------------------------------------|-------------|-------------|
| 1 | Rect-1 | 1,200.00 | 60.00 | 115.00 | 72,000 | 138,000 | 4,320,000 | 15,870,000 | 10,000.00 | 1,440,000 |
| 2 | Rect-2 | 1,200.00 | 6.00 | 60.00 | 7,200.00 | 72,000 | 43,200.00 | 4,320,000 | 1,000,000 | 14,400.00 |
| 3 | Rect-3 | 1,800.00 | 90.00 | 5.00 | 162,000 | 9,000 | 14,580,000 | 45,000.00 | 15,000 | 4,860,000 |
| Sum | | 4,200.00 | | | 241,200 | 219,000 | 18,943,200 | 20,235,000 | 1,025,000 | 6,314,400 |

$$\bar{x} = \frac{\Sigma ax}{\Sigma a} = 57.43 \text{ mm} \quad \bar{y} = \frac{\Sigma ay}{\Sigma a} = 52.14 \text{ mm}$$

$$I_x = \Sigma \bar{I}_x + \Sigma ay^2 = 1,025,000.00 + 20,235,000.00 = 21,260,000.00 \text{ mm}^4$$

$$I_y = \Sigma \bar{I}_y + \Sigma ax^2 = 6,314,400.00 + 18,943,200.00 = 25,257,600.00 \text{ mm}^4$$

$$\bar{I}_x = I_x - (\Sigma a) (\bar{y})^2 = 21,260,000.00 - (4,200.00) (2,718.88) = 9,840,714.29 \text{ mm}^4$$

$$\bar{I}_y = I_y - (\Sigma a) (\bar{x})^2 = 25,257,600.00 - (4,200.00) (3,298.04) = 11,405,828.57 \text{ mm}^4$$

Radius of gyration,

$$k_x = \sqrt{\frac{\bar{I}_x}{\Sigma a}} = 48.40 \text{ mm}$$

Radius of gyration,

$$k_y = \sqrt{\frac{\bar{I}_y}{\Sigma a}} = 52.11 \text{ mm}$$

December 2010 Examination Paper

PART A

1. (a) (i) (C) Determination of correct distance between objects or stations
(ii) (D) All of these
(iii) (B) Barrier or obstacle constructed across a water stream
(iv) (B) Arterial roads
2. (a) (i) (A) The principle of physical independence of forces
(ii) (D) All of the above
(iii) (C) A body shown separately from its surroundings and all external and internal forces acting on it
(iv) (C) The couple is replaced by another pair of forces, whose rotational effects are same
- (c) Reduce the system shown in Figure Q.2(c), to (i) single force (ii) single force and couple at A (iii) single force and couple at B

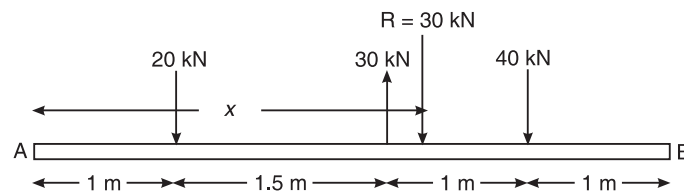

Figure Q.2(c)

- (i) $-20 + 30 - 40 = -30 \text{ kN} = 30 \text{ kN} (\downarrow)$
- (ii) From Varignon's theorem of moments, taking moments about A, we have

$$\Sigma M_A \Rightarrow 30x = 20 \times 1 - 30 \times 2.5 + 40 \times 3.5 = 85$$
or $x = 2.83$
- Applying downward and downward forces of 30 kN at A, we get,
(a) An upward acting force of 30 kN acting at A
(b) A couple of magnitude $30 \times 2.83 = 85 \text{ kNm}$
- (iii) Applying downward and downward forces of 30 kN at B, we get,
(a) An upward acting force of 30 kN acting at B
(b) A couple of magnitude $30 \times (4.5 - 2.83) = 50 \text{ kNm}$
3. (a) (i) (A) $F \cos \theta, F \sin \theta$
(ii) (A) $\tan \theta = \left(\frac{\Sigma V}{\Sigma H} \right)$
(iii) (C) Moment of resultant force R about 'X' = Moment of force P about 'X' + Moment of Q about 'X'
(iv) (B) Rotational effect of a force about a point.

- (b) The four coplanar forces acting at a point are as shown in Figure Q.3(b). One of the forces is unknown and its magnitude is as shown by F . The resultant is 500 N and is along x -axis. Determine the force F and its inclination θ with x -axis.

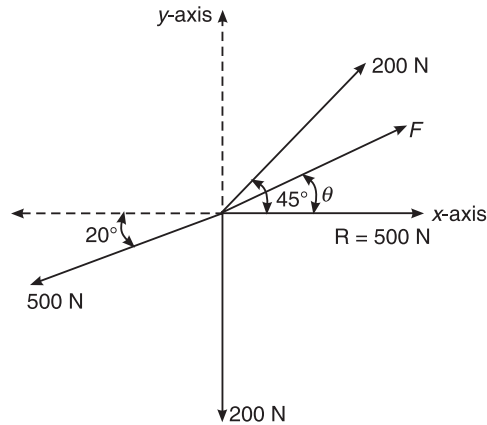

Figure Q.3(b)

Sum of horizontal components of all the forces is given by

$$(\uparrow +) \Sigma H = 500 = F \cos \theta + 200 \cos 45^\circ - 500 \cos 20^\circ$$

$$F \cos (\theta) = 828.425 \text{ kN } (\rightarrow)$$

Sum of vertical components of all the forces is given by

$$(\uparrow +) \Sigma V = 0$$

$$F \sin \theta + 200 \sin 45^\circ - 500 \sin 20^\circ - 200$$

$$F \sin \theta = 229.589 \text{ kN } (\uparrow)$$

Solving by squaring and adding, we get $F = 859.65 \text{ kN}$

Its inclination is 15.49° w.r.t. x -axis.

- (c) Four forces act on a $700 \text{ mm} \times 375 \text{ mm}$ plate as shown in Figure Q.3(c). Find the (i) resultant of these forces (ii) locate the point where the line of action of the resultant intersects the edge AB of the plate.

$$\tan \theta_1 = \frac{375}{200} \text{ or } \theta_1 = 61.93^\circ \text{ and } \tan \theta_2 = \frac{375}{500} \text{ or } \theta_2 = 36.87^\circ$$

The net forces acting along x -axis is

$$F_x = 340 \cos 61.93^\circ - 760 - 500 \cos 36.87^\circ = -1000 \text{ kN} = 1000 \text{ kN } (\leftarrow)$$

The net forces acting along y -axis is

$$F_y = 340 \sin 61.93^\circ + 600 + 500 \sin 36.87^\circ = 1200 \text{ kN } (\uparrow)$$

502 SOLUTIONS TO THE EXAMINATION PAPERS OF VTU

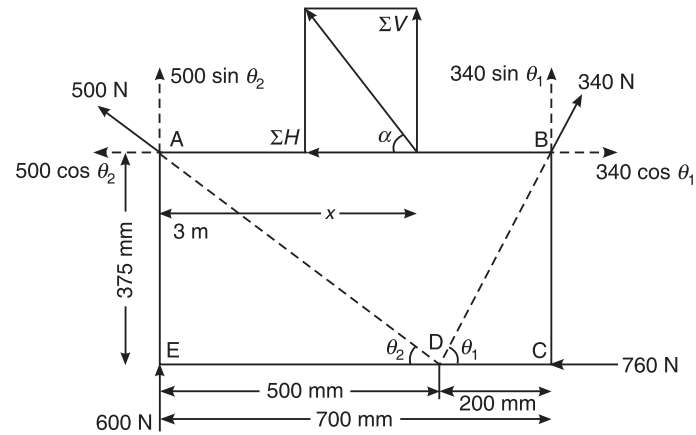

Figure Q.3(c)

Resultant of the forces is given by

$$R = \sqrt{1000^2 + 2000^2} = 1562.05 \text{ N}$$

$$\alpha = \tan^{-1} \left(\frac{1200}{1000} \right) = 50.19^\circ$$

The moment of all the components about A

$$\begin{aligned} M_A &= 1200x = (340 \sin 61.93^\circ)(700) - (760)(375) \\ &= -74995.139 \text{ Nmm} \end{aligned}$$

or $x = -62.496 \text{ mm}$ or 62.496 mm to left of A

4. (a) (i) (A) at which the whole area of the plane figure is concentrated

(ii) (B) $\frac{\sum ax}{\sum a}$

- (iii) (A) $1/3$ rd of h , $1/3$ rd of b

- (iv) (B) 0, 0

- (c) Determine the location of the centroid of the shaded portion of the lamina, shown in Figure Q.4(c), with respect to the origin O.

| S.No. | Name of Figure | Area a mm ² | Centroidal Ordinates | | ax mm ³ | ay mm ³ |
|-------|----------------|-----------------------------|----------------------|-----------|-------------------------|-------------------------|
| | | | x mm | y mm | | |
| 1 | Rect-1 | 10000 | 100 | 25 | 1000000 | 250000 |
| 2 | Tri-2 | 2500 | 133.3333 | 66.66667 | 333333.3 | 166666.7 |
| 3 | Semi-Cir-3 | 3926.991 | 150 | -21.2207 | 589048.62 | -83333.3 |
| 4 | Circ-4 | -1963.5 | 150 | 25 | -294524 | -49087.4 |
| Total | | 14463.5 | | | 1627857.9 | 284245.9 |

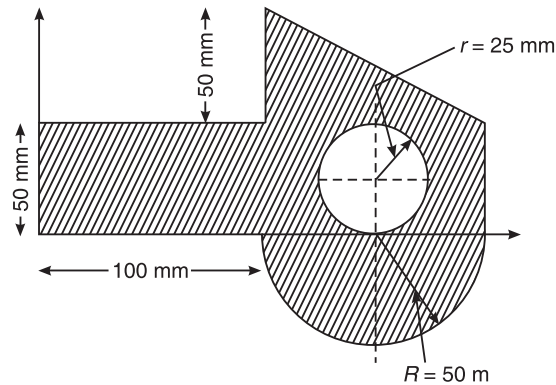

Figure Q.4(c)

$$\bar{x} = \frac{1627857.9}{14463.5} = 112.55 \text{ mm}$$

$$\bar{y} = \frac{284245.9}{14463.5} = 19.65 \text{ mm}$$

5. (a) (i) (C) Equal in magnitude, opposite in direction and collinear with the resultant
(ii) (D) All of these
(iii) (C) Coplanar concurrent forces
(iv) (B) Perpendicular to the plane of contact
- (b) Determine the tension in cables AB and AC to hold 50 kg crate, shown in Figure Q.5(b).
Take $g = 9.81 \text{ m}^2/\text{s}$

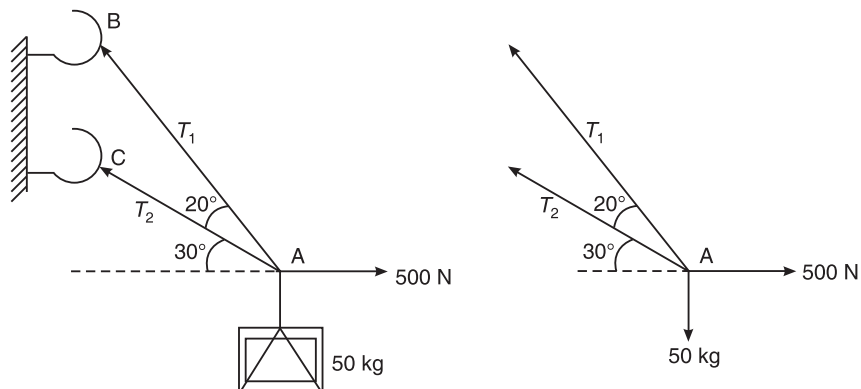

Figure Q.5(b)

From the conditions of equilibrium, we have

Sum of all the horizontal components is zero, i.e. $\Sigma H = 0$

$$500 - T_1 \cos 50^\circ - T_2 \cos 30^\circ = 0$$

or

$$0.643 T_1 + 0.866 T_2 = 500$$

(1)

504 SOLUTIONS TO THE EXAMINATION PAPERS OF VTU

Sum of all the vertical components is zero. i.e. $\Sigma V = 0$

$$T_1 \sin 50^\circ + T_2 \sin 30^\circ - 50 \times 9.81 = 0$$

$$\text{or} \quad 0.766 T_1 + 0.5 T_2 = 490.5 \quad (2)$$

Solving Eq. (1) and (2), we get $T_1 = 511.25 \text{ N}$ and $T_2 = 197.77 \text{ N}$

- (c) A system of connected flexible cables shown in Figure Q.5(c), is supporting two vertical forces 200 N and 250 N at points B and D. Determine the forces in various segments of the cable.

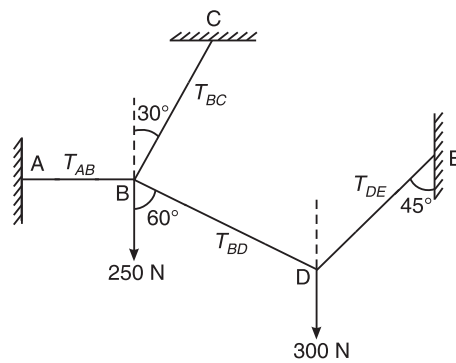
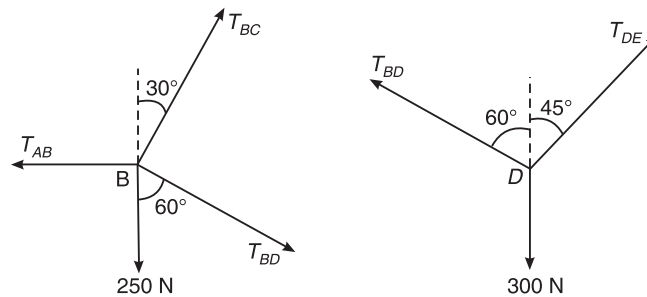

Figure Q.5(c)



Free body diagram at D is as below: Three forces are acting away at D and the system is in equilibrium. Applying Lami's theorem, we get

$$\frac{T_{DE}}{\sin(180 - 60)} = \frac{T_{BD}}{\sin(180 - 45)} = \frac{300}{\sin(60 + 45)}$$

Solving, we get

$$T_{DE} = 268.97$$

$$T_{BD} = 219.62$$

Free body diagram at B is as below: As the system is in equilibrium, resolving the concurrent forces along horizontal and vertical directions and equating their individual algebraic sum to zero, we get, sum of all the horizontal components is zero.

i.e. $\Sigma H = 0$

$$\begin{aligned} T_{BC} \sin 30^\circ + T_{BD} \sin 60^\circ - T_{AB} &= 0 \\ 0.5 T_{BC} + 190.196 - T_{AB} &= 0 \end{aligned} \quad (1)$$

Sum of all the vertical components is zero.

i.e. $\Sigma V = 0$

$$\begin{aligned} T_{BC} \cos 30^\circ - T_{BD} \cos 60^\circ - 250 &= 0 \\ 0.866 T_{BC} - 109.81 - 250 &= 0 \end{aligned}$$

or

$$T_{BC} = 415.47 \text{ N}$$

and

$$T_{AB} = 397.93 \text{ N}$$

Results:

| String | AB | BC | BD | DE |
|-------------|--------|--------|--------|--------|
| Tension (N) | 397.93 | 415.47 | 219.62 | 268.97 |

6. (a) (i) (C) Fixed Support
(ii) (C) One end is hinged and other is roller supported
(iii) (B) W kN
(iv) (D) W/2 kN, W/2 kN
(c) A beam ABCDEF is hinged at A, supported on rollers at E and carries loads as shown in Figure Q.6(c). Determine the reactions at the supports.

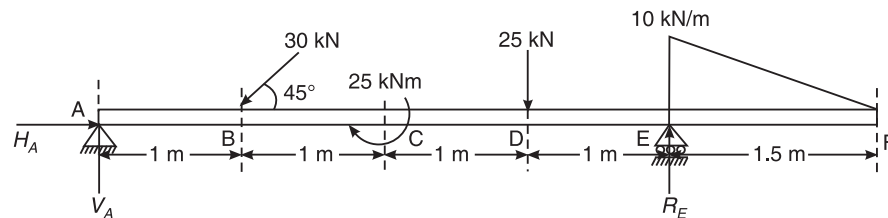

Figure Q.6(c)

From the conditions of equilibrium, we have

Sum of all the horizontal components is zero, i.e. $\Sigma H = 0$

$$H_A = 30 \cos 45^\circ = 21.213 \text{ kN } (\rightarrow)$$

Sum of all the vertical components is zero. i.e. $\Sigma V = 0$

$$V_A + R_E = 30 \sin 45^\circ + 25 + \frac{1}{2} \times 10 \times 1.5 = 53.71 \text{ kN} \quad (1)$$

Taking moments of all the components about A,

$$\begin{aligned} 4R_E &= (30 \cos 45^\circ)(1) + 25 + 25 \times 3 + \left(\frac{1}{2} \times 10 \times 1.5\right) \left(4 + \frac{1.5}{3}\right) = 154.963 \text{ kN} \\ R_E &= 38.74 \text{ kN } (\uparrow) \end{aligned}$$

506 SOLUTIONS TO THE EXAMINATION PAPERS OF VTU

Taking moments of all the components about E,

$$4V_A + \left(\frac{1}{2} \times 10 \times 1.5\right) \left(\frac{1.5}{3}\right) + 25 = (30 \cos 45^\circ)(3) + 25 \times 1 = 59.89 \text{ kN}$$

$$V_A = 14.972 \text{ kN}(\uparrow)$$

Substituting in Eq. (1), we get, $14.972 + 38.74 = 53.71 \text{ kN}$ and hence O.K.

7. (a) (i) (C) The friction acting on a body, which is at rest.
 (ii) (D) Angle of repose
 (iii) (D) The body having more roughness
 (iv) (B) Left at the ground and towards down at the wall
- (c) A 4 m ladder weighing 200 N is placed against a vertical wall as shown in Figure Q.7(c). As a man weighing 800 N reaches a point 2.7 m from A, the ladder is about to slip. Assuming that the coefficient of friction between the ladder and the wall is 0.2, determine the coefficient of friction between the ladder and the floor.

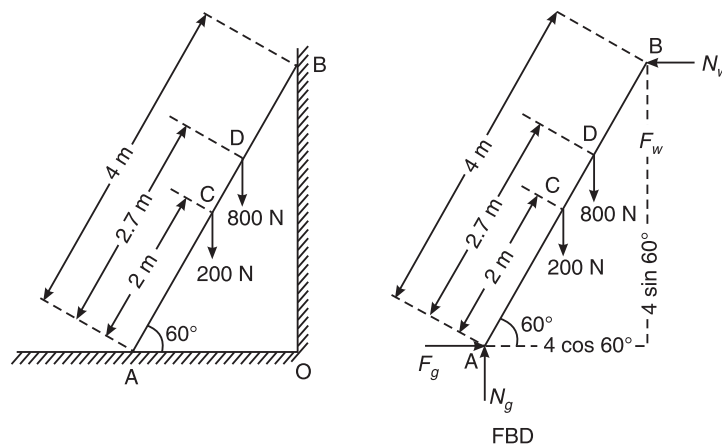

Figure Q.7(c)

From the conditions of equilibrium, we have

Sum of all the horizontal components is zero. i.e. $\Sigma H = 0$

$$F_g = \mu_g N_g = N_w \quad (1)$$

Sum of all the vertical components is zero. i.e. $\Sigma V = 0$

$$N_g + F_w = N_g + \mu_w N_w = 200 + 800 = 1000 \quad (2)$$

Taking moments of all the components about A,

$$(N_w)(4 \sin 60^\circ) + (0.2 N_w)(4 \cos 60^\circ) = (200)(2 \cos 60^\circ) + (800)(2.7 \cos 60^\circ)$$

\therefore

$$N_w = 331.25 \text{ N}$$

$$F_w = \mu_w N_w = 0.2 \times 331.25 = 66.25 \text{ N}$$

From Eq. (2), we have

$$N_g = 1000 - 66.25 = 933.75 \text{ N}$$

From Eq. (1), we have

$$331.25 = \mu_g \times 933.75$$

or

$$\mu_g = 0.355$$

8. (a) (i) (B) $\sqrt{\frac{I}{A}}$

(ii) (D) $I_{xx} + A\bar{y}^2$

(iii) (C) $\frac{bh^3}{12}$

(iv) (B) $0.11r^4$

- (c) Determine the moment of inertia and radii of gyration of the area shown in Figure Q.8(c) about the base AB and the centroidal axis parallel to AB

| S.No. | Component | Area (mm ²) | y (mm) | ay | ay ² (mm ⁴) | \bar{I}_x |
|-------|-------------|-------------------------|--------|------------|------------------------------------|--------------|
| 1 | Triangle-1 | 4,500.00 | 30.00 | 135,000.00 | 4,050,000.00 | 2,025,000.00 |
| 2 | Rectangle-2 | -600.00 | 45.00 | -27,000.00 | -1,215,000.00 | -45,000.00 |
| | Sum | 3,900.00 | | 108,000.00 | 2,835,000.00 | 1,980,000.00 |

$$\bar{y} = \frac{108,000.00}{3,900.00} = 27.69$$

Reference axis $I_{AB} = \Sigma \bar{I}_x + \Sigma ay^2 = 1,980,000.0 + 2,835,000.00 = 4,815,000.00 \text{ mm}^4$

From Parallel axis theorem, moment of inertia on centroidal x axis

$$\begin{aligned} \bar{I}_x &= I_{AB} + (\Sigma a)(\bar{y})^2 \\ &= 4,815,000.0 + 766.86 \\ &= 1,824,230.77 \text{ mm}^4 \end{aligned}$$

Radii of gyration:

$$k_{AB} = \sqrt{\frac{I_{AB}}{A}} = \sqrt{\frac{4815000}{3900}} = 35.137 \text{ mm}$$

$$k_x = \sqrt{\frac{\bar{I}_x}{A}} = \sqrt{\frac{1825230.77}{3900}} = 21.633 \text{ mm}$$

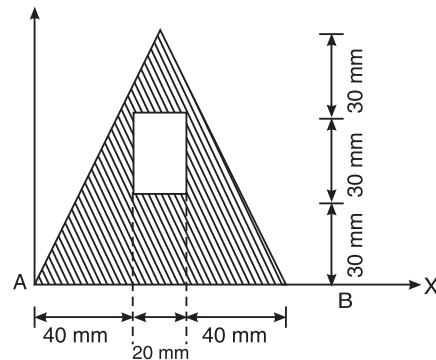

Figure Q.8(c)

May/June 2010 Examination Paper

PART A

1. (a) (i) Studying the properties of soil in assessing safe bearing capacity is called as: (D) Geotechnical Engineering
(ii) Building tanks and dams and carrying stored water to field is known as: (C) Water resources and irrigation Engineering
(iii) Kerbs are the components of: (A) Roads
(iv) Reinforced cement concrete (RCC) comes under: (D) Structural Engineering
2. (a) (i) To define a force completely, the following characteristics should be specified: (D) All of these
(ii) The net force that results from a number of individual forces acting on an object is the vector sum of the individual forces. This is termed as: (A) Principle of Superposition
(iii) Forces co-exist on a plane and all the forces act helter-skelter over the body. These are: (A) Coplanar non-concurrent forces
(iv) The principle of transmissibility states that, when a force acts upon a body, its effect is: (C) Same at every point on its line of action
- (c) Determine the equivalent system of force and couple at A for the system of loading as shown in Figure Q.2(c).

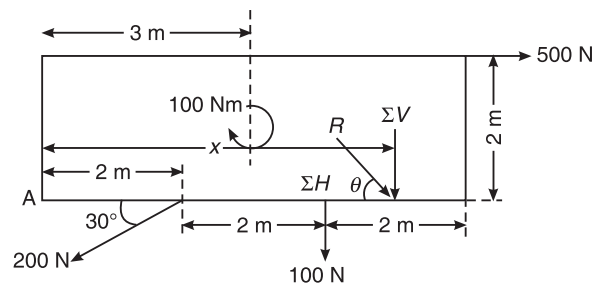

Figure Q.2(c)

Algebraic sum of all the horizontal components is given by

$$\Sigma H = 500 - 200 \cos 30^\circ = 326.795 \text{ N } (\rightarrow)$$

Algebraic sum of all the vertical components is given by

$$\Sigma V = -100 - 200 \sin 30^\circ = -200 \text{ N } = 200 \text{ N } (\downarrow)$$

Resultant force is given by

$$R = \sqrt{\Sigma H^2 + \Sigma V^2} = \sqrt{326.795^2 + 200^2} = 383.138 \text{ N}$$

Its inclination w.r.t. horizontal is given by

$$\theta = \tan^{-1} \left(\frac{\Sigma V}{\Sigma H} \right) = \tan^{-1} \left(\frac{200}{326.795} \right) = 31.47^\circ$$

From Varignon's theorem of moments, taking moment about the point A, we get

$$M_A = 200x = (500)(2) + (100)(4) + (200 \sin 30^\circ)(2) + 100$$

$$x = 8.5 \text{ m}$$

3. (a) (i) The simplest resultant of a parallel system is always: (B) A Force
(ii) The purpose of replacing a number of forces acting on a body simultaneously is: (C) to find resultant
(iii) If two forces act at an angle of 120° , the greater force is 50 N and their resultant is perpendicular to the smaller force, the smaller force is: (B) $50 \cos 60 = 25$ N
(iv) If two forces P and Q ($P > Q$) act on the same straight line but in opposite directions, the resultant is: (D) $P - Q$
- (c) The system of forces acting on a triangular plate is as shown in Figure Q.3(c). Determine magnitude, direction of the resultant and its position with respect to O .

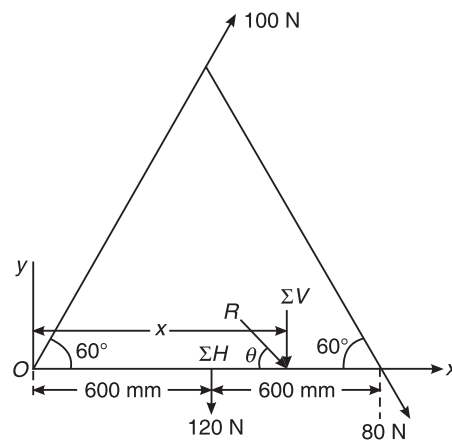
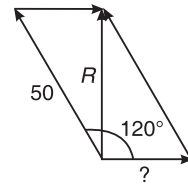

Figure Q.3(c)

Algebraic sum of all the horizontal components is given by

$$\Sigma H = 100 \cos 60^\circ + 80 \cos 60^\circ = 90 \text{ N } (\rightarrow)$$

Algebraic sum of all the vertical components is given by

$$\Sigma V = 100 \sin 60^\circ - 80 \sin 60^\circ - 120 = -102.68 \text{ N} = 102.68 \text{ N } (\downarrow)$$

Resultant force is given by

$$R = \sqrt{\Sigma H^2 + \Sigma V^2} = \sqrt{90^2 + 102.68^2} = 136.54 \text{ N}$$

Its inclination w.r.t. horizontal is given by

$$\theta = \tan^{-1} \left(\frac{\Sigma V}{\Sigma H} \right) = \tan^{-1} \left(\frac{102.68}{90} \right) = 48.765^\circ$$

510 SOLUTIONS TO THE EXAMINATION PAPERS OF VTU

From Varignon's theorem of moments, taking moment about the point A, we get

$$M_A = 102.68x = (80 \sin 60) (120) + (120) (60)$$

$$x = 151.09 \text{ mm}$$

4. (a) (i) The Centroid of a lamina: (D) is a unique point fixed with respect to the lamina
(ii) The Centroid of a triangle of height h is located at a distance from its apex which is:
(C) $\frac{2h}{3}$
(iii) Centroid conveys some clue about: (B) Centre of the body
(iv) An axis over which one half the plane figure is just the mirror of the other half is:
(B) axis of symmetry
- (c) For a shaded area shown in Figure Q.4(c), find a so that the Centroid is at O .

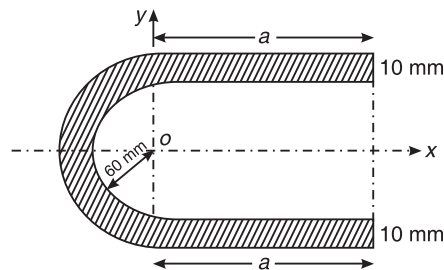

Figure Q.4(c)

$$a_1 = 140a \text{ mm}^2,$$

$$x_1 = \frac{a}{2} \text{ mm}$$

$$a_2 = -120a \text{ mm}^2,$$

$$x_2 = \frac{a}{2} \text{ mm}$$

$$a_3 = \frac{\pi \times 70^2}{2} = 7696.9 \text{ mm}^2,$$

$$x_3 = -\frac{4 \times 70}{3\pi} = -29.709 \text{ mm}$$

$$a_4 = -\frac{\pi \times 60^2}{2} = -5654.867 \text{ mm}^2,$$

$$x_4 = -\frac{4 \times 60}{3\pi} = -25.465 \text{ mm}$$

$$\bar{x} = \frac{a_1 x_1 + a_2 x_2 + a_3 x_3 + a_4 x_4}{a_1 + a_2 + a_3 + a_4}$$

$$(d) \quad 0 = \frac{(140a) \left(\frac{a}{2}\right) + (-120a) \left(\frac{a}{2}\right) + (7696.9) (-29.709) + (-5654.867) (-25.465)}{(140a) + (-120a) + (7696.9) + (-5654.867)}$$

$$70a^2 - 60a^2 - 228667.2 + 144001.19 = 0$$

$$\text{or } a = 92.01 \text{ mm}$$

PART B

5. (a) (i) The force that is equal and opposite to resultant is: (B) Equilibrant
(ii) The Lame's equation can be applied when number of unknown forces are: (B) Three
(iii) The necessary condition of equilibrium of coplanar concurrent force system is:
(B) $\Sigma F_x = 0, \Sigma F_y = 0$
(iv) A system that processes resultant: (C) will not be in equilibrium
- (c) A wire rope is fixed at two points A and D as shown in Figure Q.5(c). Weights 20 kN and 30 kN are attached to it at B and C respectively. The weights rest with portions AB and BC inclined at 30° and 50° respectively, to the vertical as shown. Find the tension in segments AB, BC and CD of the wire. Determine the inclination of segment CD to vertical (θ).

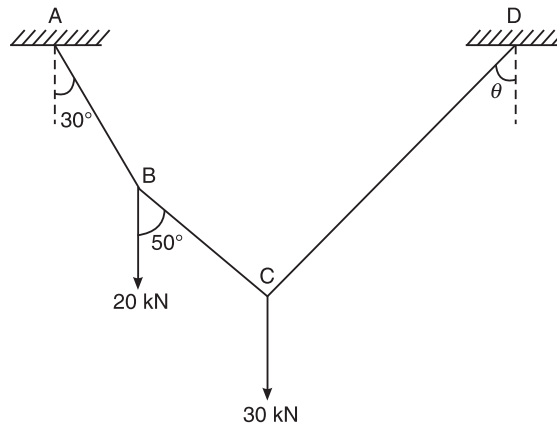
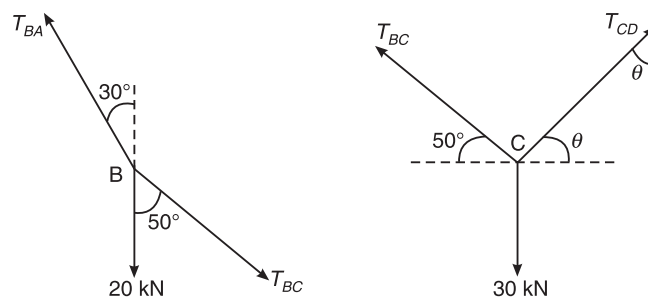
**Figure Q.5(c)**

Free body diagram at B is as shown. 3 forces are acting away at B and the system is in equilibrium. Applying Lami's theorem, we get

$$\frac{T_{BA}}{\sin(50^\circ)} = \frac{T_{BC}}{\sin(180 - 30)^\circ} = \frac{20}{\sin(30 + (180 - 50))^\circ}$$

Solving, we get

$$T_{BA} = 44.795 \text{ kN}$$

$$T_{BC} = 29.238 \text{ kN}$$

512 SOLUTIONS TO THE EXAMINATION PAPERS OF VTU

Free body diagram at C is as shown. Three forces are acting away at B and the system is in equilibrium. Applying Lami's theorem, we get

$$\frac{T_{BC}}{\sin(90 + \theta)} = \frac{T_{CD}}{\sin(90 + 50)} = \frac{30}{\sin(180 - (50 + \theta))}$$

$$0.643 \times 29.238 = T_{CD} \times \sin(90 + \theta) \Rightarrow T_{CD} \times [\sin(90) \cos(\theta) + \cos(90) \sin(\theta)]$$

$$T_{CD} \cos(\theta) = 18.8$$

$$0.643 \times 30 = T_{CD} \times \sin(50 + \theta) = 19.284$$

$$30 \times \sin(90 + \theta) = 29.238 \times \sin(50 + \theta)$$

$$\text{But, } 30 \times [\sin(90) \cos(\theta) + \cos(90) \sin(\theta)] = 30 \cos(\theta)$$

$$\text{and } 29.238 \times \sin(50 + \theta) = 29.238 \times [\sin(50) \cos(\theta) + \cos(50) \sin(\theta)]$$

$$\text{or } 22.398 \cos(\theta) + 18.794 \sin(\theta) = 30 \cos(\theta)$$

solving $\theta = 22.02^\circ$

$$T_{CD} = \frac{18.8}{\cos(22.02)} = 20.278 \text{ kN}$$

Results:

| String | AB | BC | CD |
|-------------|--------|--------|--------|
| Tension (N) | 44.795 | 29.238 | 20.278 |

6. (a) (i) A beam is said to be determinate, if: (A) the reactions can be determined using the equations of equilibrium
(ii) The beam is neither permitted to move in any direction nor allowed to rotate in the case of: (B) Fixed support
(iii) uvl stands for: (D) Uniformly varying load
(iv) A thin rigid beam hinged at one end and roller-supported at its mid-point is said to be: (B) a overhanging beam
- (b) Determine the reactions at the supports for the system shown in Figure Q.6(c). Consider the top beam CD

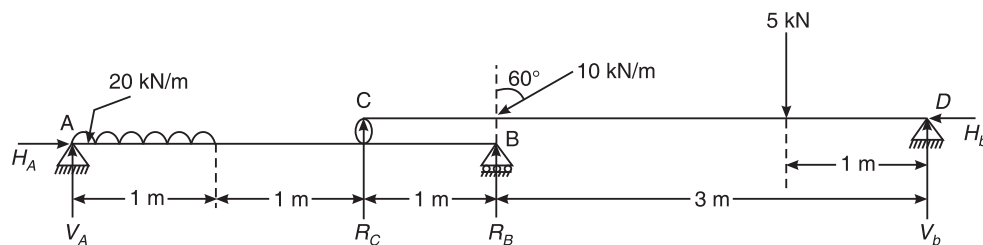
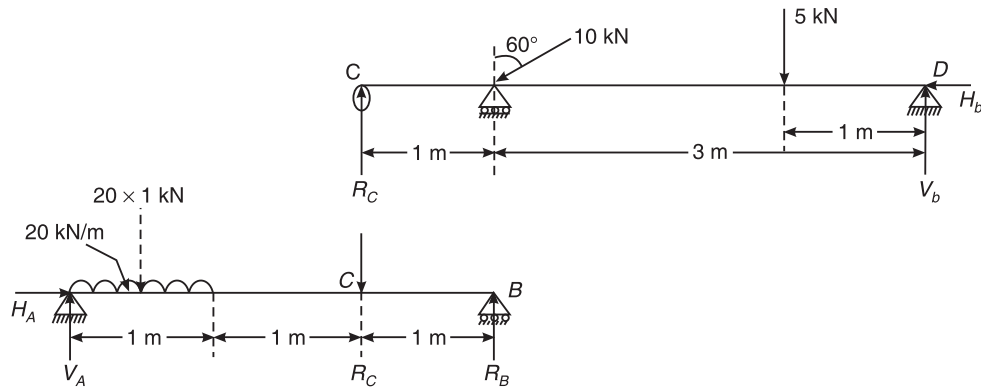

Figure Q.6(c)



From the conditions of equilibrium, we have

Sum of all the horizontal components is zero, i.e. $\Sigma H = 0$

$$H_D = 10 \sin 60^\circ = 8.66 \text{ kN } (\leftarrow)$$

Sum of all the vertical components is zero, i.e. $\Sigma V = 0$

$$R_C + V_D = 10 \cos 60^\circ + 5 = 10 \text{ kN} \quad (1)$$

Taking moments of all the components about D,

$$4R_C = (10 \cos 60^\circ)(3) + 5 \times 1$$

$$R_C = 5 \text{ kN } (\uparrow)$$

Taking moments of all the components about C,

$$4V_D = (10 \cos 60^\circ)(1) + 5 \times 3 = 20 \text{ kN}$$

$$V_D = 5 \text{ kN } (\uparrow)$$

Substituting in Eq. (1), we get, $5 + 5 = 10 \text{ kN}$, and hence O.K.

Consider the bottom beam AB

From the conditions of equilibrium, we have

Sum of all the Horizontal components is zero, i.e. $\Sigma H = 0$

$$H_D = 0$$

Sum of all the vertical components is zero, i.e. $\Sigma V = 0$

$$V_A + R_B = (20)(1) + 5 = 25 \text{ kN} \quad (2)$$

Taking moments of all the components about B,

$$3V_A = (20 \times 1) \left(2 + \frac{1}{2} \right) + 5 \times 1 = 55$$

$$V_A = 18.33 \text{ kN } (\uparrow)$$

514 SOLUTIONS TO THE EXAMINATION PAPERS OF VTU

Taking moments of all the components about B,

$$3R_B = (20 \times 1) \left(\frac{1}{2} \right) + 5 \times 2 = 20 \text{ kN}$$

$$R_B = 6.67 \text{ kN } (\uparrow)$$

Substituting in Eq. (2), we get, $18.33 + 6.67 = 25 \text{ kN}$, and hence O.K.

7. (a) (i) The frictional force is independent of: (A) the area of contact
(ii) Once a body just begins to slide, it continues to slide because: (D) the frictional force becomes less
(iii) The coefficient of friction between two surfaces is the constant of proportionality between the applied tangential force and the normal reaction: (C) at any instant of impending motion
(iv) The angle of friction is angle between: (D) the normal reaction and the resultant
- (c) In Figure Q.7(c), determine the value of P , just required to lift 3000 N up. The angle of friction between block and the wall is 15° and for other surfaces it is 18° .

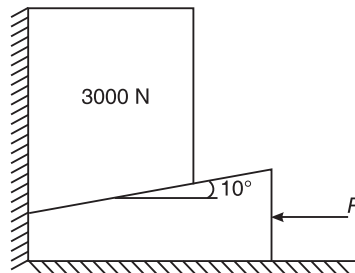

Figure Q.7(c)

Consider the FBD of block. Three forces are acting on the block:

- (i) Weight of block acting vertically downwards
- (ii) Reaction with the wall acting at angle ϕ_w with the normal to wall
- (iii) Reaction with the wedge acting at angle ϕ_w with the normal the plane

$$\phi_w = 15^\circ \text{ and } \phi_b = \phi_g = 18^\circ$$

As the system is in equilibrium, Lami's theorem can be applied.

$$\frac{3000}{\sin(\phi_w + 90 + 10 + \phi_b)} = \frac{R_b}{\sin(90 - \phi_w)} = \frac{R_w}{\sin(180 - (10 + \phi_b))}$$

$$R_b = 3962.21 \text{ N and } R_w = 1925.76 \text{ N}$$

Consider the FBD of wedge. Three forces are acting on the block:

- (i) Force P acting horizontally
- (ii) Reaction with the ground acting at angle ϕ_g with the normal to ground
- (iii) Reaction with the block acting at angle ϕ_w with the normal the plane

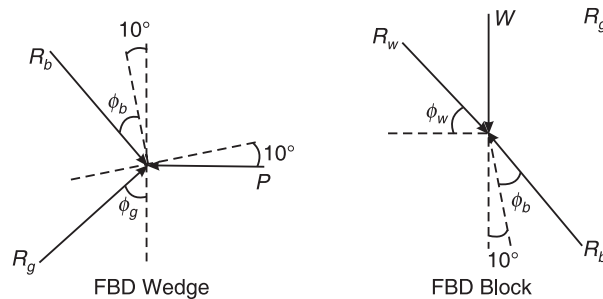

As the system is in equilibrium, Lami's theorem can be applied.

$$\frac{P}{\sin(180 - 10 - \phi_b - \phi_g)} = \frac{R_g}{\sin(90 + 10 + \phi_b)} = \frac{R_b}{\sin(90 + \phi_g)}$$

$$R_g = 3678.46 \text{ N and } P = 2996.85 \text{ N}$$

8. (a) (i) The moment of inertia of a rectangular lamina of sides b and h about its neutral axis parallel to the sides b is given by: (B) $\frac{bh^3}{36}$
- (ii) The unit of radius of gyration of an area is: (D) m
- (iii) The value of moment of inertia depends upon: (D) Cross-sectional dimension
- (iv) Moment of inertia is a: (C) fourth order term
- (d) Find the moment of inertia of the area shown in Figure Q.8(d) about its centroidal axis parallel to the coordinate axis.

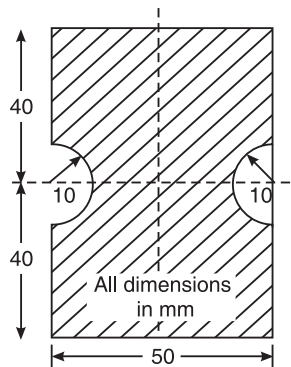

Figure Q.8(d)

Moment of Inertia on Centroidal x axis

$$\bar{I}_x = \frac{50 \times 80^3}{12} - 2 \times \left[\frac{\pi(10)^4}{8} \right] = 2125479.35 \text{ mm}^4$$

Moment of Inertia on Centroidal y axis

$$\bar{I}_y = \frac{80 \times 50^3}{12} - 2 \times \left[0.11 \times 10^4 + \left(\frac{\pi \times 10^2}{2} \right) \left(25 - \frac{4 \times 10}{3\pi} \right)^2 \right] = 697991.62 \text{ mm}^4$$

Dec. 2009/Jan. 2010 Examination Paper

PART A

1. (a) (i) The part of civil engineering which deals with design of slabs, beams, columns, footings etc is called: (B) Structural Engineering
(ii) The science of map making is known as: (B) Surveying
(iii) The structure which provides passage over the obstacles like valley, river without closing the way underneath is: (B) Bridge
(iv) Pickup a structure in which an inspection gallery is formed: (A) Gravity Dam
2. (a) (i) Principle of transmissibility of forces states that when a force acts upon a body its effect is: (C) Same at every point on its line of action
(ii) Two parallel forces equal in magnitude and opposite in direction and separated by a definite distance are said to form: (B) Couple
(iii) Effect of a force on a body depends upon its: (D) All of these
(iv) The forces which pass through a single point and lie in the same plane are: (C) Coplanar concurrent forces

$$\theta = \tan^{-1}\left(\frac{3}{4}\right) = 36.87^\circ$$

$$(c) F_{1x} = F_1 \sin \theta = 1200 \sin 36.87^\circ = 720 \text{ N}$$

$$F_{1y} = F_1 \cos \theta = 1200 \cos 36.87^\circ = 960 \text{ N}$$

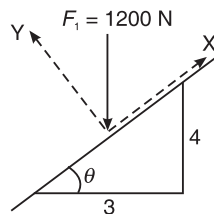

$$(d) M_A = -(500 \sin 30^\circ) \times 6 = -1500 \text{ N-m} = 1500 \text{ N-m (}\odot\text{)}$$

$$M_B = (500 \cos 30^\circ) \times 2 - (500 \sin 30^\circ) \times 6 = -633.975 \text{ N-m} = 633.975 \text{ N-m (}\odot\text{)}$$

$$M_C = (500 \cos 30^\circ) \times 3 - (500 \sin 30^\circ) \times 6 = -200.962 \text{ N-m} = 200.962 \text{ N-m (}\odot\text{)}$$

$$M_D = (500 \cos 30^\circ) \times 3 = 1299.038 \text{ N-m} = 200.962 \text{ N-m (}\odot\text{)}$$

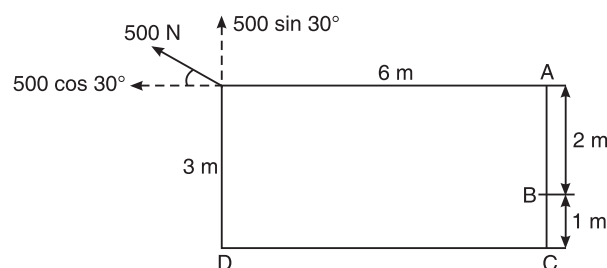

Figure Q.2(d)

3. (a) (i) The single force which will have the same effect as the system of forces is: (B) Resultant
(ii) If two forces M and N ($M > N$) act on the same straight line but in opposite direction, their resultant is: (D) ($M-N$)
(iii) If the resultant of coplanar concurrent force system acts along horizontal X-axis, then: (B) $\Sigma F_x = R$
(iv) The resultant of force system shown in Figure Q.3(a)(iv): (C) 76.32 N

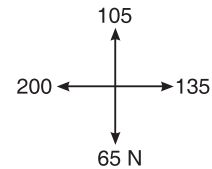

Figure Q.3(a)(iv)

- (b) Three forces acting on a hook are as shown in Figure Q.3(b). Find the direction of the fourth force of magnitude 100 N such that the hook is pulled in X-directions only. Find the resultant force.

The net forces acting along x-axis is

$$F_x = 80 \cos 60^\circ + 80 \cos 30^\circ + 200 \cos 60^\circ + 100 \cos \theta$$

$$= 180 + 100 \cos \theta$$

$$F_y = 80 \sin 60^\circ + 80 \sin 30^\circ - 200 \sin 60^\circ - 100 \sin \theta = 0$$

$$\text{or } 100 \sin \theta = -63.923$$

$$\text{or } \theta = -39.73^\circ = 39.73^\circ (\swarrow)$$

$$\text{and } R = 180 + 100 \cos 39.73^\circ = 256.902 \text{ N}$$

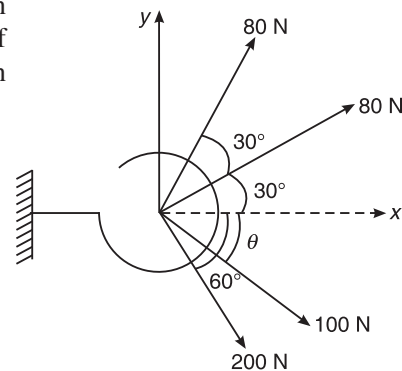

Figure Q.3(b)

- (c) Find magnitude and direction of the resultant force; also find X and Y intercepts of resultant force with respect to point A [refer Figure Q.3(c)]. The net force acting along x direction is

$$F_x = 15000 \times 2 - 100 \cos 36.97^\circ$$

$$= 29920 \text{ N} (\rightarrow)$$

$$F_y = 100 \sin 36.97^\circ - \frac{1}{2} \times 20000 \times 2$$

$$= -19940 \text{ N} = 19940 \text{ N} (\downarrow)$$

Resultant of the forces is given by

$$R = \sqrt{29920^2 + 19940^2} = 35955.667 \text{ N}$$

$$\alpha = \tan^{-1} \left(\frac{29920}{19940} \right) = 56.319^\circ$$

The moment of all the components about A

$$M_o = \left[\frac{1}{2} \times 20000 \times 3 \right] \times \left[\frac{3}{3} \right] - 10000 - (15000 \times 2) \times \left(\frac{2}{2} \right) = -10000 \text{ Nm}$$

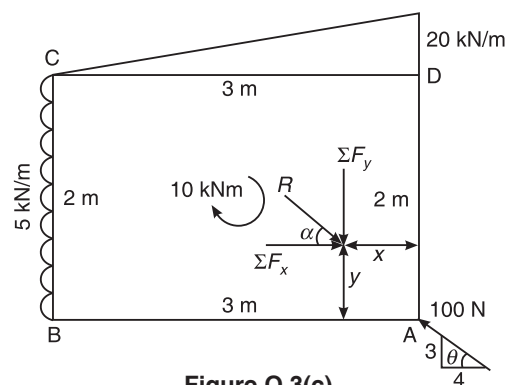

Figure Q.3(c)

518 SOLUTIONS TO THE EXAMINATION PAPERS OF VTU

$$x \text{ intercept} = \frac{M_o}{\Sigma F_y} = \frac{-10000}{19940} = -0.5015 \text{ m}$$

$$y \text{ intercept} = \frac{M_o}{\Sigma F_x} = \frac{-10000}{29920} = -0.3342 \text{ m}$$

4. (a) (i) The centroid of a triangle of height h is located at a _____ distance from its base:
 (C) $\frac{h}{3}$
- (ii) An axis over which one half of the plane figure is just mirror image of the other half, is: (A) Axis of symmetry
- (iii) If the given plane figure is symmetrical about vertical Y-Y axis, the centroid lies on:
 (B) Vertical YY-axis
- (iv) The centroid of a plane lamina will not be at its geometrical centre if it is a: (C) Right-angled triangle
- (b) Find C.G. of the shaded area, Figure Q.4(b) with respect to given X and Y axes.

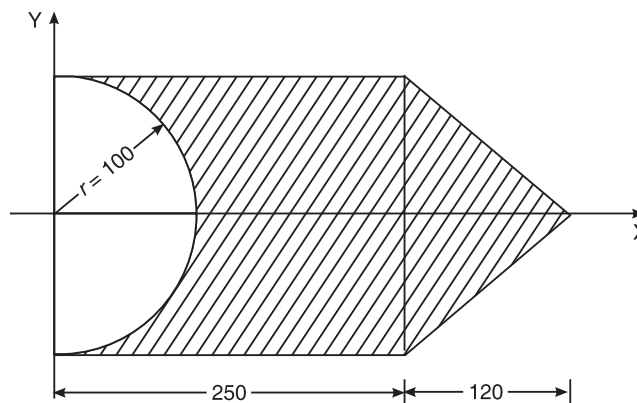

Figure Q.4(b)

| S.No. | Name of Figure | Area | Ordinates | ax |
|-------------------------|----------------|---------------|---------------|---------------|
| | | a | x | |
| | | mm^2 | mm | mm^3 |
| 1 | Rect-1 | 50000 | 125 | 6250000 |
| 2 | Triangle | 12000 | 40 | 480000 |
| 3 | Semicircle | -15708 | 42.44132 | -666667 |
| $\Sigma \text{ Area} =$ | | 46292.04 | $\Sigma ax =$ | 6063333 |

$$\bar{x} = 0$$

$$\bar{y} = \frac{6063333}{46292.04} = 130.9801 \text{ mm}$$

The Centroid of the given figure w.r.t. O is (0,130.98)

(c) Find C.G. of the shaded area, Figure Q.4(c) with respect to given X and Y axes.

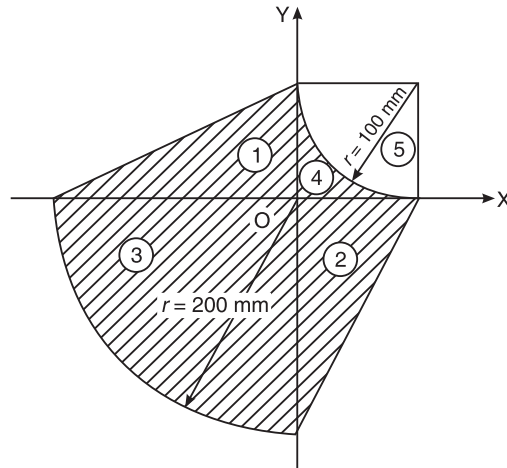

Figure Q.4(c)

| S.No. | Name of Figure | Area a mm^2 | Centroidal Ordinates | | ax mm^3 | ay mm^3 |
|---------------------------------|----------------|------------------------------|------------------------|--------------------|------------------------|-----------------------|
| | | | x mm | y mm | | |
| 1 | Tri-1 | 20000 | -66.6667 | 33.33333 | -1333333 | 666666.7 |
| 2 | Tri-2 | 20000 | 33.33333 | -66.6667 | 666666.7 | -1333333 |
| 3 | Quad-3 | 31415.93 | -84.8826 | -84.8826 | -2666667 | -2666667 |
| 4 | Rect-4 | 10000 | 50 | 50 | 500000 | 500000 |
| 5 | Quad-5 | -15708 | 57.55868 | 57.55868 | -904130 | -904130 |
| $\Sigma \text{Area} = 65707.96$ | | | $\Sigma ax = -3737463$ | | $-3737463 = \Sigma ay$ | |

$$\bar{x} = \frac{-3737463}{65707.96} = -56.8799 \text{ mm}$$

$$\bar{y} = \frac{-3737463}{65707.96} = -56.8799 \text{ mm}$$

The Centroid of the given figure w.r.t. O is $(-56.8799, -56.8799)$

PART B

5. (a) (i) The force which is equal and opposite to resultant is: (B) Equilibrant
(ii) The Lami's equation can be applied when number of unknown forces are: (B) Three
(iii) The necessary condition of equilibrium of coplanar concurrent force system is:
(B) $\Sigma F_x = 0, \Sigma F_y = 0$
(iv) A system that possesses a resultant: (C) Will not be in equilibrium

520 SOLUTIONS TO THE EXAMINATION PAPERS OF VTU

- (b) Find the tension in the string and reaction at the contact surface for the cylinder of weight 1000 N placed as shown in Fig. Q.5(b). Solve by Lami's theorem.

$$W = 1000 \text{ N}$$

From Lami's theorem, we have

$$\frac{1000}{\sin(60 + 50)^\circ} = \frac{T}{\sin(180 - 50)^\circ} = \frac{R}{\sin(180 - 60)^\circ}$$

$$T = \frac{\sin(180 - 50)^\circ}{\sin(60 + 50)^\circ} \times 1000 = 815.21 \text{ N}$$

$$R = \frac{\sin(180 - 60)^\circ}{\sin(60 + 50)^\circ} \times 1000 = 921.61 \text{ N}$$

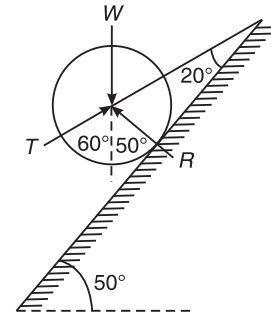

Figure Q.5(b)

- (c) In the Figure Q.5(c) shown, the portion BC is horizontal. Pulley is frictionless. Find the tension in each part of the string and also find W_1 and W_2 using equations of equilibrium only.

Applying Lami's theorem for forces acting at point C

$$\frac{100}{\sin 90^\circ} = \frac{T_{CB}}{\sin 135^\circ} = \frac{W_2}{\sin 135^\circ}$$

$$T_{CB} = \frac{\sin 135^\circ}{\sin 90^\circ} \times 100 = 70.71 \text{ N}$$

$$W_2 = \frac{\sin 135^\circ}{\sin 90^\circ} \times 100 = 70.71 \text{ N}$$

Applying Lami's theorem for forces acting at point B

$$\frac{T_{BA}}{\sin 90^\circ} = \frac{T_{CB}}{\sin 150^\circ} = \frac{W_1}{\sin 120^\circ}$$

$$T_{BA} = \frac{\sin 90^\circ}{\sin 150^\circ} \times 70.71 = 141.42 \text{ N}$$

$$W_1 = \frac{\sin 120^\circ}{\sin 150^\circ} \times 70.71 = 122.47 \text{ N}$$

6. (a) (i) The number of reaction components at a hinged end of a beam are: (B) 2
 (ii) UDL stands for: (C) Uniformly Distributed Load
 (iii) A cantilever beam is one in which: (C) One end is fixed and other end is free
 (iv) At the fixed end of cantilever, number of unknown reaction components are: (C) 3
- (b) Find the reactions for a cantilever beam shown in Figure Q.6(b). From the conditions of equilibrium algebraic sum of vertical forces is zero

$$\Sigma V_A = 0$$

$$R_A = 10 + 10 \times 2 = 30 \text{ kN}$$

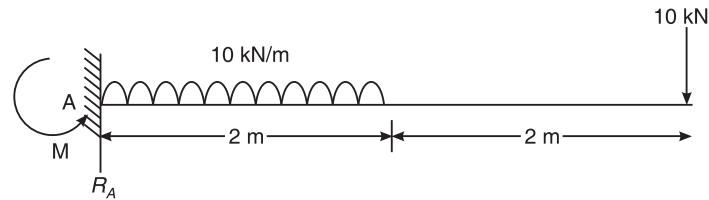

Figure Q.6(b)

Algebraic sum of moments about A is zero

$$\Sigma M_A = 0$$

$$M_A = 10 \times 4 + (10 \times 2) \times \left(\frac{2}{2}\right) = 60 \text{ kN-m}$$

(c) Find the reactions at A and B for beam shown in Figure Q.6(c).

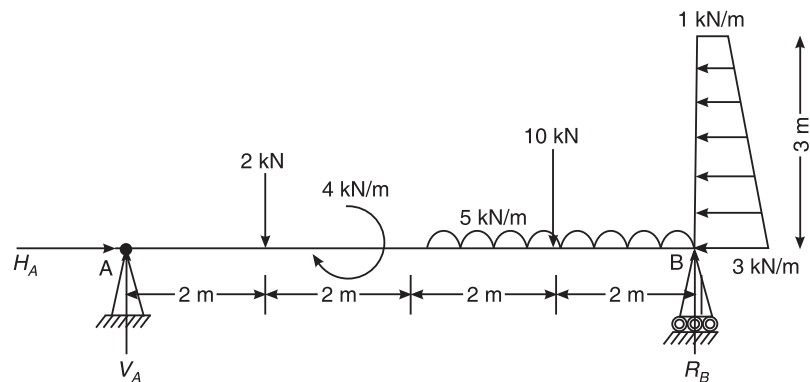

Figure Q.6(c)

From the conditions of equilibrium, net forces along horizontal and vertical directions are zero.

$$\Sigma H = 0'$$

$$H_A = (1 \times 3) \left(\frac{3}{2}\right) + \left[\left(\frac{1}{2}\right) \times (2 \times 3)\right] \left(\frac{3}{3}\right) = 7.5 \text{ kN}$$

$$\Sigma V = 0'$$

$$V_A + R_B = 2 + 10 + (5 \times 4) = 32 \text{ kN}$$

Algebraic sum of Moment of all forces about A is zero

$$\Sigma M_A = 0'$$

522 SOLUTIONS TO THE EXAMINATION PAPERS OF VTU

$$8R_B + (1 \times 3) \left(\frac{3}{2} \right) + \left[\left(\frac{1}{2} \right) \times (2 \times 3) \right] \left(\frac{3}{3} \right)$$

$$= 2 \times 2 + 10 \times 6 + (5 \times 4) \times \left(4 + \frac{4}{2} \right) + 4 = 188 \text{ kNm}$$

or $R_B = 22.5625 \text{ kN}$

Algebraic sum of Moment of all forces about B is zero

$$\Sigma M_B = 0'$$

$$8V_A + 4 = 2 \times 6 + 10 \times 2 + (5 \times 4) \times \left(\frac{4}{2} \right) + (1 \times 3) \left(\frac{3}{2} \right) + \left[\left(\frac{1}{2} \right) \times (2 \times 3) \right] \left(\frac{3}{3} \right) = 79.5 \text{ kNm}$$

or $V_A = 9.4375 \text{ kN}$

Check:

$$V_A + R_A = 9.4375 + 22.5625 = 32 \text{ kN}$$

7. (a) (i) Coefficient of friction (μ) is given by: (B) $\mu = \frac{F}{R}$
- (ii) If ϕ is angle of friction and μ is coefficient of friction, then which equation is valid?
(A) $\tan(\phi) = \mu$
- (iii) If ϕ is the angle of friction and α is angle of response then which relation is correct?
(B) $\phi = \alpha$
- (iv) Force of friction developed at contact surface is: (A) Opposite to the direction of motion
- (c) A small block of weight 1000 N is placed on a 30° incline with coefficient of friction = 0.25 as shown in Figure Q.7(c). Find the horizontal force P required to be applied for:
(i) Impending motion down the plane and (ii) Impending motion up the plane.

$$\mu = 0.25$$

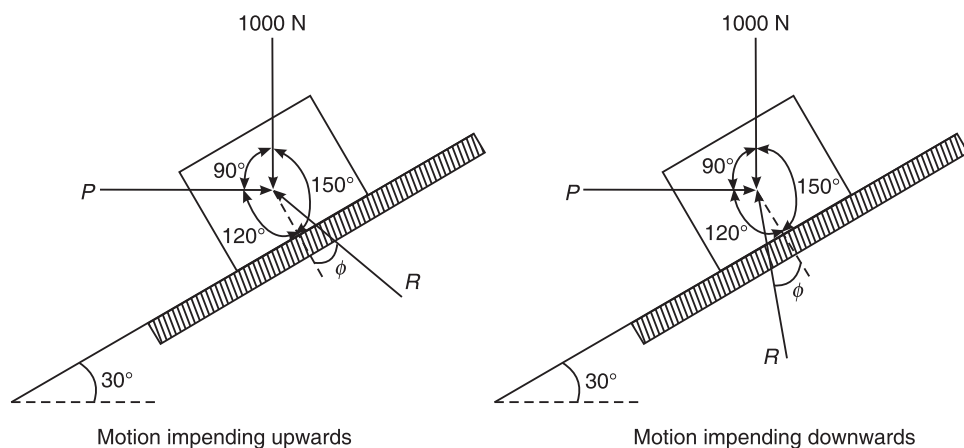

Figure Q.7(c)

(a) Motion impending upwards

Applying Lami's theorem,

$$\frac{R}{\sin(90)} = \frac{1000}{\sin(120 + \phi)} = \frac{P}{\sin(150 - \phi)}$$

$$P = \frac{\sin(150 - 14.04)}{\sin(120 + 14.04)} \times 1000 = 966.91 \text{ N}$$

$$R = \frac{\sin(90)}{\sin(120 + 14.04)} \times 1000 = 1391.01 \text{ N}$$

(b) Motion impending downwards

Applying Lami's theorem,

$$\frac{R}{\sin(90)} = \frac{1000}{\sin(120 - \phi)} = \frac{P}{\sin(150 + \phi)}$$

$$P = \frac{\sin(150 + 14.04)}{\sin(120 - 14.04)} \times 1000 = 286.06 \text{ N}$$

$$R = \frac{\sin(90)}{\sin(120 - 14.04)} \times 1000 = 1040.11 \text{ N}$$

8. (a) (i) The unit of moment of inertia of an area is: (C) m^4 (ii) The moment of inertia of a square of side b about the centroidal axis: (A) $\frac{b^4}{12}$ (iii) The moment of inertia of a triangle of base b and height h about its base is: (D) $\frac{bh^3}{12}$ (iv) The polar moment of inertia of a circular section of diameter D about its centroidal axis is: (B) $\frac{\pi}{32} D^4$ (c) Find the polar moment of inertia of the section shown in Figure Q.8(c), about an axis passing through its centroid, and hence, find polar radius of gyration. Figure Q.8(c) is symmetrical about y axis and \bar{x} is zero

Figure Q.8(c)

524 SOLUTIONS TO THE EXAMINATION PAPERS OF VTU

| S.No. | Figure | Area | Centroidal axis | ay | ay^2 | Moment of Inertia | |
|-------|--------------|------------------------|--|-----------------|-----------------|-------------------------------------|--|
| | | a mm ² | y mm | mm ³ | mm ⁴ | \bar{I}_x mm ⁴ | \bar{I}_y mm ⁴ |
| 1 | Rect-1 | $24 \times 4 =$ 96 | $\frac{4}{2} =$ 2 | 192 | 384 | $\frac{24 \times 4^3}{12} =$ 128 | $\frac{4 \times 24^3}{12} =$ 4608 |
| 2 | Rect-2 | $4 \times 12 =$ 48 | $4 + \frac{12}{2} =$ 10 | 480 | 4800 | $\frac{4 \times 12^3}{12} =$ 576 | $\frac{12 \times 4^3}{12} =$ 64 |
| 3 | Semicircle-3 | 56.549 | $16 + \frac{4 \times 6}{3\pi} =$ 18.546 | 1048.779 | 19451.15194 | 142.56 | $0.11 \times 6^4 =$ $\frac{\pi \times 6^4}{8} =$ 508.938 |
| Total | | 200.549 | | 1720.779 | 24635.152 | 846.560 | 5180.938 |

$$\bar{y} = \frac{\Sigma ay}{\Sigma a} = \frac{1720.779}{200.549} = 8.58 \text{ mm}$$

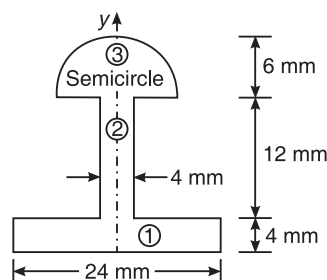
$$I_b = \bar{I}_x + A\bar{y}^2$$

$$I_b = \Sigma \bar{I}_x + \Sigma ay^2 = 19593.7 \text{ mm}^4$$

$$\bar{I}_x = I_b - A\bar{y}^2 = 15430.5 \text{ mm}^4$$

$$I_y = \bar{I}_y + A\bar{x}^2$$

$$\bar{I}_y = \Sigma \bar{I}_y + 0 = 142.56 \text{ mm}^4$$

$$J = \bar{I}_x + \bar{I}_y = 15573.018 \text{ mm}^4$$

$$k_z = \sqrt{\frac{J}{A}} = 8.812 \text{ mm}^4$$

June/July 2009 Examination Paper

PART A

1. (a) (i) A branch of civil engineering dealing with the technical measures to use and protect components of environment is: (D) Environmental engineering
(ii) Composite material consisting of cement concrete and steel used in civil engineering structural construction is: (B) Reinforced Cement Concrete (RCC)
(iii) Highways which are superior to National highways and are provided wherever volume of traffic is very high are: (D) Expressways
(iv) A bridge constructed at some angle to river flow is: (A) Skew bridge
2. (a) (i) Forces whose lines of action lie along the same line are: (B) Collinear forces
(ii) An object regarded as only mass but no size in mechanics is: (D) Particle
(iii) Moment of a force about a moment centre is the measure of its: (B) rotational effect
(iv) The translatory effect of a couple on the rigid body is: (C) Zero
- (c) Find the moment of force about A and B for 30 kN force shown in Figure Q.2(c).

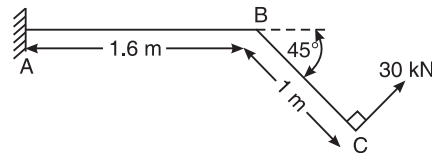

$$\begin{aligned} \text{Moment about A} &= (30 \cos 45^\circ \times 1 \sin 45^\circ) + (30 \sin 45^\circ \times 1 \cos 45^\circ) \\ &= 63.94 \text{ kN-m} \end{aligned}$$

$$\text{Moment about B} = 30 \times 1 = 30 \text{ kN-m}$$

- (d) A door needs 7500 N-mm to open it. Mr. X applies the force at the edge of the door shutter which is at a distance of 750 mm from the hinge and Mr. Y applies it at a distance of 500 mm from the hinge.

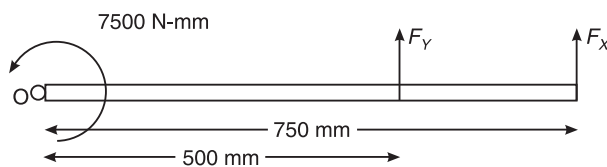

$$\text{Moment of } F_X \text{ about O} = 7500 = F_X \times 750$$

$$\text{Hence, } F_X = 10 \text{ N}$$

$$\text{Moment of } F_Y \text{ about O} = 7500 = F_Y \times 500$$

$$\text{Hence, } F_Y = 15 \text{ N}$$

3. (a) (i) Component of a force at right angles to its line of action is: (A) zero
(ii) If two concurrent forces each of P act at right angles to each other, their resultant is: (C) $P\sqrt{2}$

526 SOLUTIONS TO THE EXAMINATION PAPERS OF VTU

- (iii) The resultant force of two concurrent forces become maximum and minimum if angle between them is: (A) 0° and 180°
- (iv) A rigid body acted upon by coplanar non-concurrent forces system has: (A) Both translatory and rotary motion
- (b) A truck is to be pulled along a straight road as shown in Figure Q.3(b)

(i)

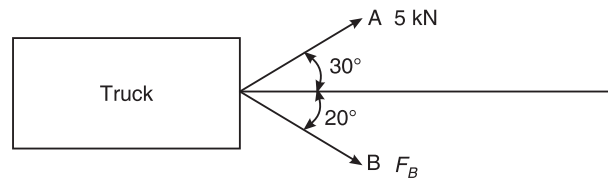

(ii)

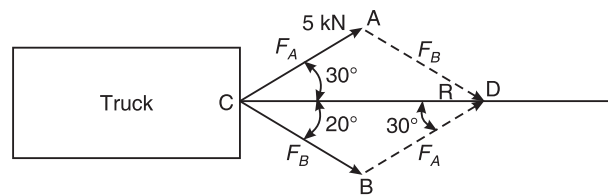

FBD

Figure Q.3(b)

Complete the Parallelogram CADB as shown in figure. Consider the triangle CBD. Applying Sine rule, we have

$$\frac{F_A}{\sin 20^\circ} = \frac{F_B}{\sin 30^\circ} = \frac{R}{\sin 150^\circ}$$

For $F_A = 5$ kN, $F_B = \frac{\sin 30^\circ}{\sin 20^\circ} \times 5 = 7.3095$ kN

If $F_B = 4$ kN and its angle is θ , then $\frac{5}{\sin \theta} = \frac{4}{\sin 30^\circ}$ and $\theta = \sin^{-1} \left[\frac{5}{4} \times \sin 30^\circ \right] = 38.68^\circ$

(c) $\theta_1 = \tan^{-1} \left[\frac{2}{4} \right] = 26.565^\circ$, and $\theta_2 = \tan^{-1} \left[\frac{2}{2} \right] = 45^\circ$

The algebraic sum of horizontal components of all the forces = F_x

$$F_x = 300 \cos 26.565^\circ - 100 + 250 - 100 \cos 45^\circ = 347.618 \text{ N } (\rightarrow)$$

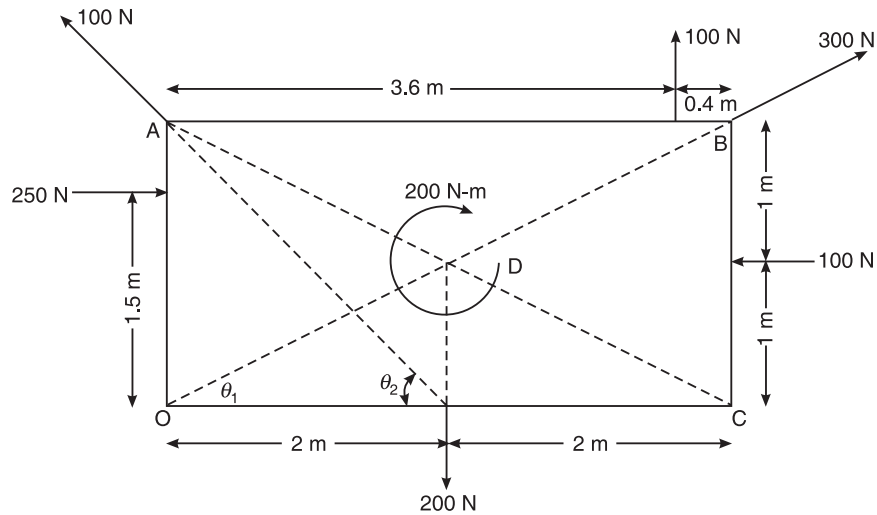

The algebraic sum of vertical components of all the forces = F_y

$$F_y = 100 + 300 \sin 26.565^\circ - 200 + 100 \sin 45^\circ = 104.875 \text{ N } (\uparrow)$$

$$R = \sqrt{F_x^2 + F_y^2} = 363.093 \text{ N}$$

Its inclination from horizontal = $\tan^{-1} \left[\frac{F_y}{F_x} \right] = 16.788^\circ$

From Varignon's theorem of moments, taking moments about O,

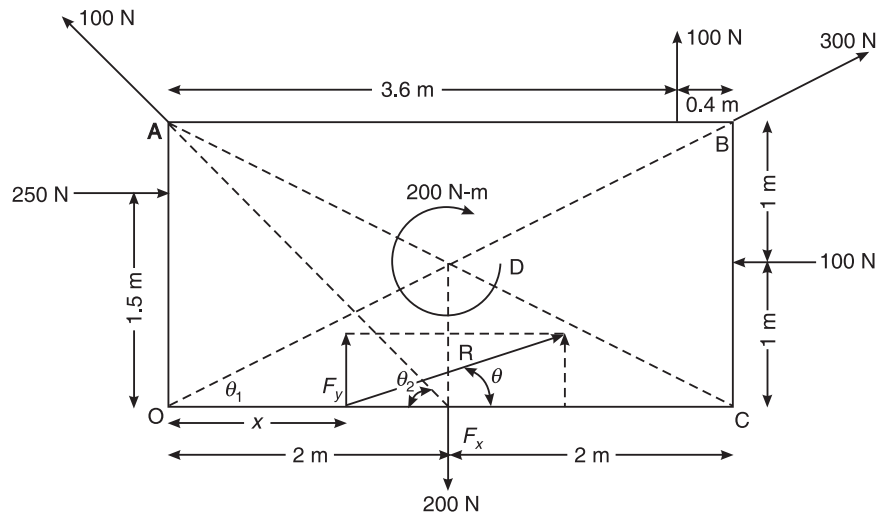

$$104.875 x = (100 \cos 45^\circ) (2) + (100) (3.6) + 300 \times 0 + (100) (1) - (200) (2) - (250) (1.5) - 200$$

$$x = -3.562 \text{ m} = 3.562 \text{ m (to left of O).}$$

528 SOLUTIONS TO THE EXAMINATION PAPERS OF VTU

4. (a) (i) Centroid of plane is the point at which: (B) surface area is assumed to be concentrated.
- (ii) Centroid of quarter of circular lamina lies from diameter line at a distance of: (C) $\frac{4R}{3\pi}$
- (iii) Centroid of trapezium of height h and parallel sides a and b measured from base b is at a distance of: (C) $\frac{h}{3} \left(\frac{b+2a}{a+b} \right)$
- (iv) The centroid of a triangular lamina of height h is situated at a distance _____ from its apex: (B) $\frac{2h}{3}$
- (c) Locate centroid of lamina shown in figure with respect to point A

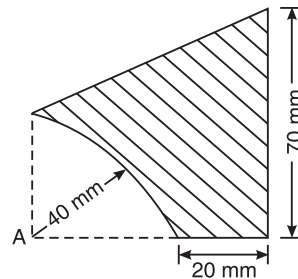

| S.No. | Component | Area (mm ²) | x (mm) | y (mm) | ax | ay |
|-------|-------------|-------------------------|--------|--------|------------|------------|
| 1. | Rectangle 1 | 2,400.00 | 30.00 | 20.00 | 72,000.00 | 48,000.00 |
| 2. | Triangle 2 | 900.00 | 40.00 | 50.00 | 36,000.00 | 45,000.00 |
| 3. | Rectangle 3 | -1,256.64 | 16.98 | 16.98 | -21,333.33 | -21,333.33 |
| Total | | 2,043.36 | | | 86,666.67 | 71,666.67 |

$$\bar{x} = \frac{86666.67}{2043.36} = 42.414 \text{ mm} \quad \text{and} \quad \bar{y} = \frac{71666.67}{2043.36} = 35.07 \text{ mm}$$

5. (a) (i) A rigid body is in equilibrium if the resultant force of concurrent force system is: (C) zero
- (ii) A system of forces that possesses resultant force move in: (A) the direction of line of action of the resultant.
- (iii) Lami's theorem is valid for: (C) Three concurrent forces in equilibrium
- (iv) For a smooth spherical surface reaction acts: (C) Perpendicular to the plane of contact
- (b) Of forces shown in Figure Q.5(b) (i) and (ii) are in equilibrium or not. If not state the type of motion that exists.
- (i) The algebraic sum of horizontal components of all the forces = F_x

$$F_x = 10 - 30 \cos 30^\circ = -15.98 = 15.98 \text{ N}$$

The algebraic sum of vertical components of all the forces = $F_y = 30 \sin 30^\circ - 15 = 0 \text{ N}$

Hence the body moves towards left horizontally.

- (ii) The algebraic sum of horizontal components of all the forces = F_x

$$F_x = 5 - 5 = 0 \text{ N}$$

The algebraic sum of vertical components of all the forces = F_y

$$F_y = 10 - 10 = 0 \text{ N}$$

Taking moment of all the force components about A,

$$\sum M_A = 5 \times 100 + 10 \times 200 + 10 = 2510 \text{ N-mm.}$$

The body does not have translatory motion, but rotates anticlockwise.

- (c) Three cylinders weighing 500 N each 24 units diameter are placed in channel as shown in figure. Take cylinders are smooth.

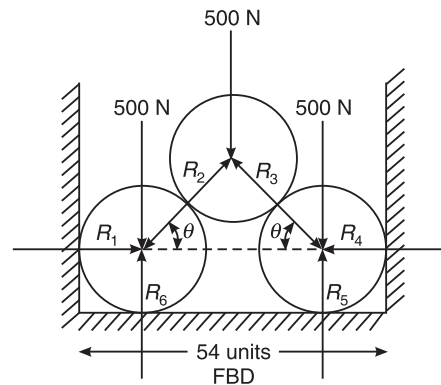
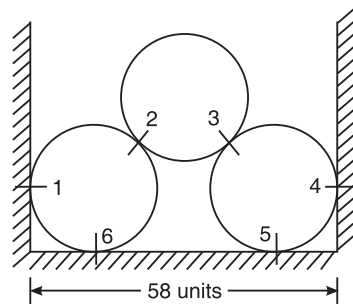

It can be seen from the figure that the forces are symmetrical and hence the forces $R_1 = R_4$, $R_2 = R_3$ and $R_5 = R_6$

$$\theta = \cos^{-1} \left[\frac{58 - 24}{\frac{2}{24}} \right] = 45^\circ$$

Applying Lami's theorem for top cylinder, we have

$$\frac{500}{\sin(2\theta)} = \frac{R_2}{\cos \theta}$$

$$R_2 = 353.35 \text{ N} = R_3$$

530 SOLUTIONS TO THE EXAMINATION PAPERS OF VTU

Applying Lami's theorem for left bottom cylinder, we have

$$\frac{(R_6 - 500)}{\sin \theta} = \frac{353.53}{\sin 90^\circ} = \frac{R_1}{\cos \theta}$$

$$R_1 = 250 \text{ N} = R_4$$

$$R_6 = 750 \text{ N} = R_5$$

Check

For equilibrium, sum of vertical forces must be zero.

$$\text{i.e. } \Sigma F_y = 500 + 500 + 500 = R_5 + R_6 = 750 + 750 = 1500.$$

Hence, O.K.

6. (a) (i) Reaction line at roller support with respect to plane of contact is: (C) Perpendicular
(ii) Support reactions for statically determined beams can be determined by applying:
(A) Conditions of static equilibrium
(iii) When load acts at constant rate over given length of beam it is called: (B) udl
(iv) A beam having one end hinged support and other roller support subjected to vertical loading can be regarded as: (C) Simply supported beam
- (c) A beam ABCDE has a flexible link BC as shown in Figure Q.6(c). Determine the support reaction at A, D and E.

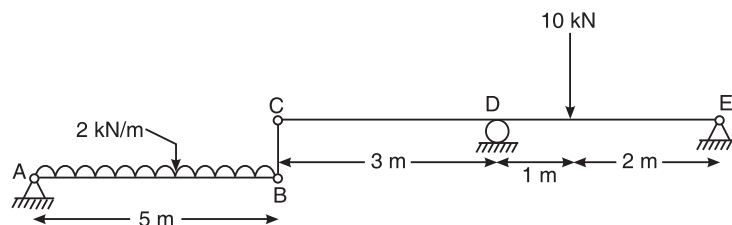

Consider the beam AB. The loading is symmetrical and hence the Reactions R_A and R_B are same. From the conditions of equilibrium,

$$R_A + R_B = 2R_A = 2R_B = 2 \times 5; R_A = R_B = 5 \text{ kN}$$

Consider the Beam CDB. From the conditions of equilibrium,

$$R_D + R_E = R_C + 10 = 15 \text{ kN}$$

Algebraic sum of moments about D is zero

$$5 \times 3 + 3R_E = 10 \times 1$$

$$R_E = -1.67 \text{ kN} = 1.67 \text{ kN}$$

Algebraic sum of moments about E is zero

$$3R_D = 5 \times 6 + 10 \times 2$$

$$R_D = 16.67 \text{ kN}$$

Check

$$R_A + R_D + R_E = 5 + 16.67 - 1.67 \Rightarrow 2 \times 5 + 10 = 20 \text{ kN}$$

7. (a) (i) The maximum frictional force developed when a body just begins to slide over the surface of an other body is: (C) Limiting friction
(ii) The angle which an inclined surface makes with the horizontal when a body placed on it, it is in the verge of moving down is called: (A) Angle of repose
(iii) Frictional force is independent of: (C) Shape and size of surface of contact
(iv) Compared to static friction, kinematic friction is: (B) Smaller
- (c) A uniform bar AB 5 m long weighing 280 N is hinged at B, rest upon 400 N block at A as shown in Figure Q.7(c). If the coefficient of friction is 0.4 for all contact surfaces, find the horizontal force P required to move the block 400 N block.

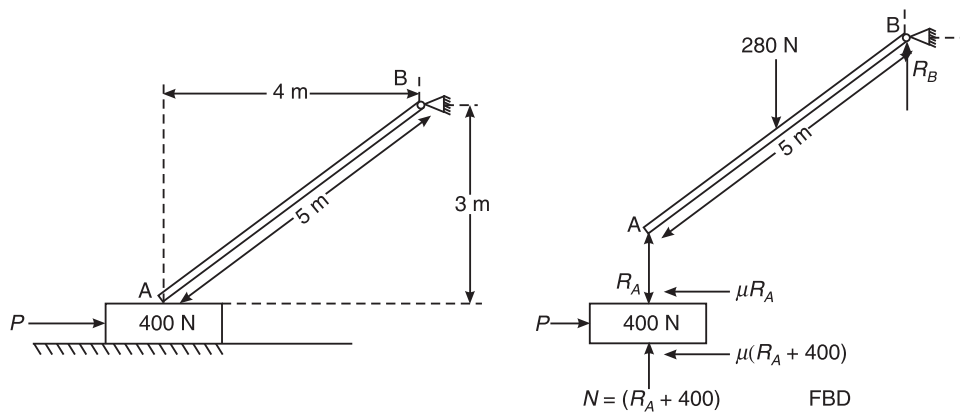

Consider the beam AB. The loading is symmetrical, and hence, the reactions are equal.

$$R_A = R_B = 140 \text{ N}$$

Consider the equilibrium of the block. The algebraic sum of horizontal components is equal.

$$P = \mu R_A + \mu(R_A + 400) = 0.4(140 + 140 + 400) = 272 \text{ N}$$

8. (c) Figure Q.8(c) is having both the centroidal ordinates in x and y directions same. Hence, only the computations are done on one axis.

$$\bar{x} = \frac{\sum ax}{\sum a} = \frac{789333.33}{8796.46} = 89.73 \text{ mm} = \bar{y}$$

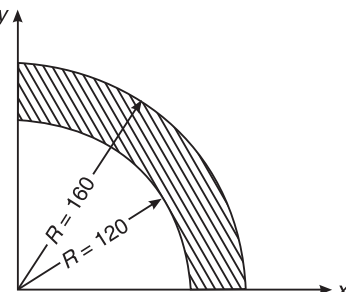

532 SOLUTIONS TO THE EXAMINATION PAPERS OF VTU

| S.No. | Component | Area (mm ²) | x (mm) | ax | ax ² (mm ⁴) | \bar{I}_x |
|-------|------------|-------------------------|--------|--------------|------------------------------------|----------------|
| 1. | Quadrant 1 | 20,106.19 | 67.19 | 1,365,333.33 | 92,714,474.23 | 36,044,800.00 |
| 2. | Quadrant 2 | -11,309.73 | 50.93 | -576,000.00 | -29,335,439.11 | -11,404,800.00 |
| | Sum | 8,796.46 | | 789,333.33 | 63,379,035.12 | 24,640,000.00 |

Moment of inertia of the figure about the base = I_x

$$I_x = 24,640,000.00 + 63,379,035.12 = 88,019,035.12 \text{ mm}^4 = I_x$$

From Parallel axis theorem, $\bar{I}_x = I_x - ax^2$

$$\bar{I}_x = 88,019,035.12 - 8,796.46 (89.73)^2 = 17,189,729.75 \text{ mm}^4 = \bar{I}_x$$

Solutions to problems of July 2009 Question Paper CV13/23 (2002 Scheme)

4. (b) Determine the resultant of the force system shown in figure

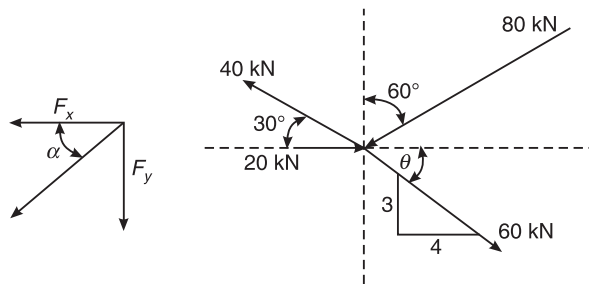

$$\theta = \tan^{-1}\left(\frac{3}{4}\right) = 36.87$$

$$F_x = -80 \sin 60^\circ + 60 \sin 36.87^\circ + 20 - 40 \cos 30^\circ$$

$$F_x = -47.92 \text{ kN} = 47.92 \text{ kN}$$

$$F_y = 40 \sin 30^\circ - 80 \cos 60^\circ - 60 \sin 36.87^\circ = -56 \text{ kN}$$

$$F_y = 56 \text{ kN}$$

$$R = \sqrt{47.92^2 + 56^2} = 73.706 \text{ kN}$$

$$\alpha = \tan^{-1}\left(\frac{56}{47.92}\right) = 49.446$$

5. (c) Determine the reactions at the support of a beam loaded as showed in Figure Q.4(b)

From the conditions of equilibrium, we have $\sum H = 0$, $\sum V = 0$ and $\sum M = 0$

$$\sum H = 0, R_A \sin 60^\circ = H_B \quad (1)$$

$$\sum V = 0, R_A \cos 60^\circ + V_B = \left(\frac{1}{2} \times 2 \times 1.5\right) + 4 = 5.5 \text{ kN} \quad (2)$$

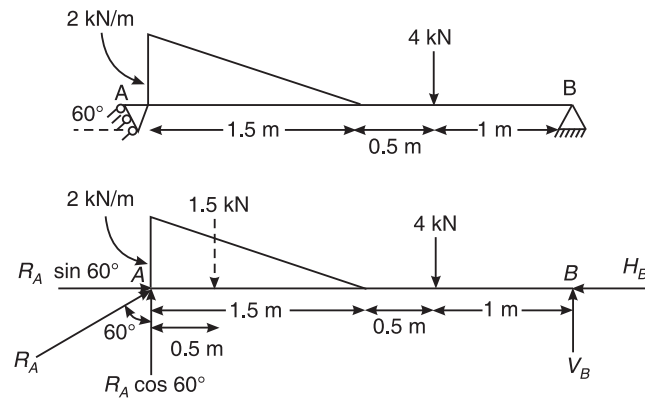

Algebraic sum of moment about A

$$3V_B = 4 \times 2 + \left(\frac{1}{2} \times 2 \times 1.5\right) \left(\frac{1.5}{3}\right) \text{ or } V_B = 2.91 \text{ kN}$$

$$3R_A \cos 60^\circ = 4 \times 1 + \left(\frac{1}{2} \times 2 \times 1.5\right) \left(1.5 + \frac{2}{3} \times 1.5\right) \text{ or } R_A = 5.167 \text{ kN}$$

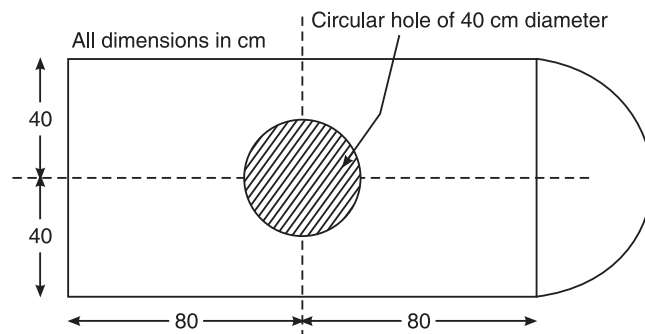

Substituting in Eq. (2), we have $5.167 \cos 60^\circ + 2.917 = 5.5 \text{ kN}$

Substituting in Eq. (1), we have $H_B = 5.167 \sin 60^\circ = 4.47 \text{ kN}$

6. (b) Calculate the polar moment of inertia of the area shown in Figure Q.7(b) about an axis through A.

| S.No. | Component | Area (mm ²) | x (mm) | y (mm) | ax | ay | \bar{I}_x | \bar{I}_y |
|-------|------------|----------------------------|-----------|-----------|--------------|------------|----------------|---------------|
| 1. | Rect 1 | 12,800.00 | 80.00 | 40.00 | 1,024,000.00 | 512,000.00 | 6,826,666.67 | 27,306,666.67 |
| 2. | S-circle 2 | 2,513.27 | 176.98 | 40.00 | 444,790.53 | 100,530.96 | 1,005,309.65 | 281,600.00 |
| 3. | Circle 3 | -1,256.64 | 80.00 | 40.00 | -100,530.96 | -50,265.48 | -125663.7061 | -125,663.71 |
| Total | | 14,056.63 | | | 1,368,259.57 | 562,265.48 | 7,706,312.6139 | 27,462,602.96 |

534 SOLUTIONS TO THE EXAMINATION PAPERS OF VTU

Moments of Inertia about (A) reference axes, x and y respectively are

$$I_x = 7,706,312.6139 \text{ mm}^4 \quad \text{and} \quad I_y = 27,462,602.96$$

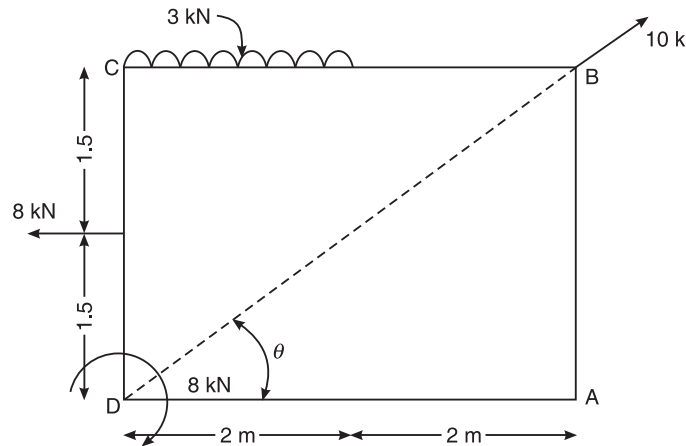

Figure Q.7(b)

7. (b) Determine the resultant of a coplanar, non-concurrent force system shown in Figure Q.7(b) with respect to A.

The algebraic sum of horizontal components of all the forces = F_x

$$F_x = 10 \cos 36.87^\circ - 8 = 0 \text{ N}$$

The algebraic sum of vertical components of all the forces = F_y

$$F_y = 3 \times 2 - 10 \sin 36.87^\circ = 0 \text{ N}$$

$$R = 0 \text{ N}$$

From Varignon's theorem of moments, taking moments about A

$$\curvearrowleft + \sum M_A = 0 = (10 \cos 36.87^\circ)(3) - (8)(1.5) - (3 \times 2)(2 + 1) + 8 = 2 \text{ kN-m} (\curvearrowright)$$

The resultant of the system of forces and moment about A is to an anticlockwise moment of 2 kN-m.

$$\theta = \tan^{-1} \frac{3}{4} = 36.87^\circ$$

8. (b) A ladder of length 5 m and weight 80 N is placed against a smooth vertical wall and on a rough horizontal ground at an inclination of 30° with the vertical. The ladder supports a man weighing 600 N on it at a height of 3 m above the ground level in the limiting case. Determine the coefficient of friction between the ladder and the ground.

$$L = 5 \text{ m}; W = 80 \text{ N}; W_1 = 600 \text{ N}; \mu_g = ?$$

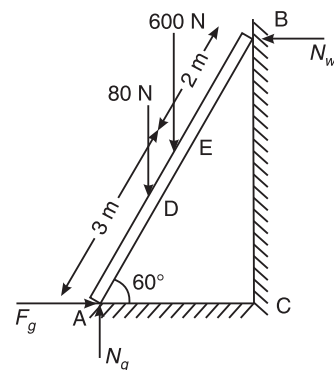

Let μ_f = Coefficient of friction between ladder and floor

$$\Sigma F_y = 0$$

$$N_g = 80 + 600 = 680 \text{ N}$$

$$F_g = \mu_g N_g = 680 \mu_g$$

Now taking moment at B

$$N_g \times 5 \cos(60^\circ) - F_g \times 5 \sin(60^\circ)$$

$$-80 \times 2.5 \cos(60^\circ) - 600 \times 2 \cos(60^\circ)$$

$$680 \times 1.710 - \mu_g \times 680 \times 5 \sin(60^\circ) - 80 \times 1.197 - 600 \times 0.855 = 0$$

$$\mu_f = 0.188$$

Dec. 2008/Jan. 2009 Examination Paper

PART A

1. (a) (i) Geotechnical Engineering involves the study of: (B) soil
 (ii) By-pass road is constructed: (C) Around the city
 (iii) The part of civil engineering which deals with waste water and solid waste is called: (C) Sanitary
 (iv) A bascule bridge is a: (D) Movable bridge
2. (a) (i) Moment of a force can be defined as the product of force and distance from the line of action of force to the moment centre: (A) Least
 (ii) Effect of force on a body depends on: (D) All the above
 (iii) The forces which meet at one point have their line of action in different plane are called: (B) Non coplanar concurrent forces
 (iv) Couple means two forces acting parallel: (C) Equal in magnitude, but opposite in direction
- (d) Replace the horizontal 600 N force acting on the lever as shown in Figure Q.2(d) by an equivalent system consisting of a force and a couple at O .

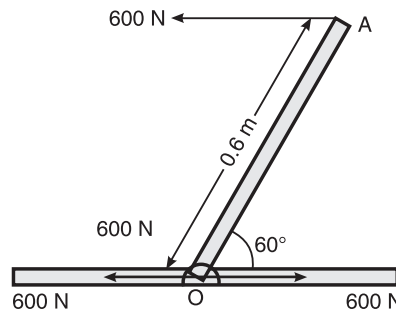

Figure Q.2(d)

Let two forces of 600 N act at O horizontally in opposite directions. The two 600 N acting in opposite directions separated by a perpendicular distance $0.6 \sin 60^\circ = 0.5196$ m form a couple of magnitude $600 \times 0.5196 = 311.769$ Nm and a horizontal force 600 N acting at O towards left.

3. (a) (i) The technology of finding the resultant of a system of forces is called: (C) Composition
 (ii) Equilibrant is nothing, but a resultant: (B) Equal in magnitude, but opposite in direction
 (iii) If two forces P and Q ($P > Q$) act on the same straight line, but in opposite direction, their resultant is: (D) $P - Q$
 (iv) In coplanar concurrent force system, if $\sum H = 0$, then the resultant is: (B) vertical
- (c) Determine the magnitude, direction of the resultant force for the force system shown in Figure Q.3(c). Determine the X intercepts of the resultant force with respect to the point O .

Algebraic sum of all the horizontal components is given by

$$\begin{aligned}\Sigma H &= 4 - 5 \cos 26.56^\circ \\ &= -0.472 = 0.472 \text{ N}\end{aligned}$$

Algebraic sum of all the vertical components is given by

$$\begin{aligned}\Sigma V &= -6 - 5 \sin 26.56^\circ \\ &= -8.236 = 8.236 \text{ N}\end{aligned}$$

Resultant force is given by

$$\begin{aligned}R &= \sqrt{\Sigma H^2 + \Sigma V^2} \\ &= \sqrt{0.472^2 + 8.236^2} = 8.249 \text{ N}\end{aligned}$$

Its inclination w.r.t. horizontal is given by

$$\theta = \tan^{-1} \left(\frac{\Sigma V}{\Sigma H} \right) = \tan^{-1} \left(\frac{8.236}{0.472} \right) = 90^\circ$$

From Varignon's theorem of moments, taking moment about the point O,

$$\begin{aligned}M_0 &= 8.326x + 8 + (5 \sin 26.56) (2) = 4 \times 1.2 \\ x &= -0.921 \text{ m or } 0.921 \text{ m to left of O}\end{aligned}$$

4. (a) (i) Moment of total area about its centroidal axis is: (C) zero
(ii) The centroid of a semicircle of Radius R about its centroidal axis parallel to its diametric axis is: (D) $\frac{4R}{3\pi}$
(iii) An axis over which one half of the plane figure is just mirror of the other half which is: (B) Axis of symmetry.
(iv) Centroid of a right angled triangle with base b and depth d is: (A) $\frac{b}{3}$ and $\frac{d}{3}$
- (c) Locate the centroid of an area shown in Figure Q.4(c) with respect to OX and OY.

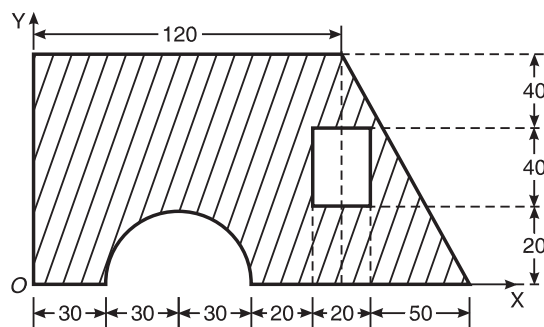

Figure Q.4(c)

538 SOLUTIONS TO THE EXAMINATION PAPERS OF VTU

| S.No. | Component | Area A (mm ²) | x (mm) | y (mm) | ax | ay |
|------------|--------------|--|--------------------------|---------------------------------------|-------------------|-------------------|
| 1. | Rectangle 1 | $120 \times 100 =$ 12,000.00 | $120/2 =$ 60.00 | 50.00 | 720,000.00 | 600,000.00 |
| 2. | Triangle 2 | $60 \times 100/2 =$ 3,000.00 | $120 + 60/3 =$ 140.00 | 33.33 | 420,000.00 | 100,000.00 |
| 3. | Rectangle 3 | $-20 \times 40 =$ -800.00 | 120.00 | 40.00 | -96,000.00 | -32,000.00 |
| 4. | Semicircle 4 | $\frac{\pi \times 30^2}{2} =$ -1,413.72 | 60.00 | $\frac{4 \times 30}{3\pi} =$ 12.73 | -84,823.00 | -18,000.00 |
| Sum | | 12,786.28 | | | 959,177.00 | 650,000.00 |

$$\bar{x} = \frac{\sum ax}{\sum a} = 75.02 \text{ mm}$$

$$\bar{y} = \frac{\sum ay}{\sum a} = 50.84 \text{ mm}$$

PART-B

5. (a) (i) A rigid body is in equilibrium under the action of three forces. It implies that the forces must be such that the: (C) Both A and B
- (ii) Lami's theorem: (A) relates the forces with the sines of angles
- (iii) If sum of all the forces acting on a body is zero, it may be concluded that the body: (C) may be in equilibrium provided the forces are concurrent
- (iv) The necessary condition of equilibrium of concurrent force system is: (A) the algebraic sum of horizontal and vertical forces must be zero.
- (c) A wire rope is fixed at two points A and D as shown in Figure Q.5(c). Weights 20 kN and 30 kN are attached to it at B and C respectively. The weights rest with portions AB and BC inclined at 30° and 50° respectively, to the vertical as shown. Find the tension in segments AB, BC and CD of the wire. Determine the inclination of segment CD to vertical (θ).

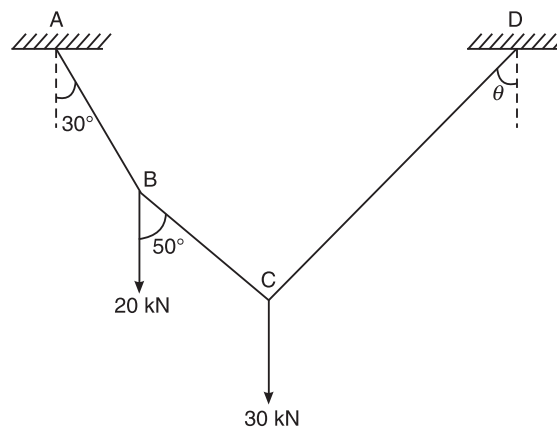
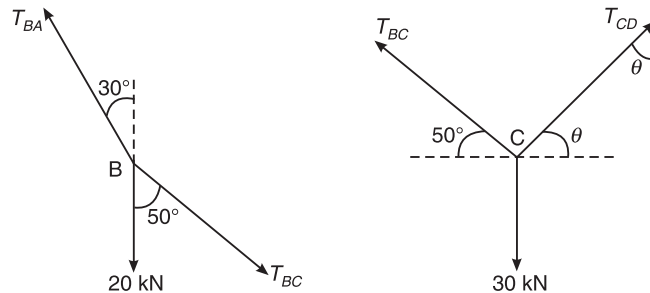

Figure Q.5(c)



Free body diagram at B is as shown. Three forces are acting away at B and the system is in equilibrium. Applying Lami's theorem, we get

$$\frac{T_{BA}}{\sin(50)^\circ} = \frac{T_{BC}}{\sin(180 - 30)^\circ} = \frac{20}{\sin(30 + (180 - 50))^\circ}$$

Solving, we get

$$T_{BA} = 44.795 \text{ kN}$$

$$T_{BC} = 29.238 \text{ kN}$$

Free body diagram at C is as shown. Three forces are acting away at B and the system is in equilibrium. Applying Lami's theorem, we get

$$\frac{T_{BC}}{\sin(90 + \theta)^\circ} = \frac{T_{CD}}{\sin(90 + 50)^\circ} = \frac{30}{\sin(180 - (50 + \theta))^\circ}$$

$$0.643 \times 29.238 = T_{CD} \times \sin(90^\circ + \theta) \Rightarrow T_{CD} \times [\sin(90)^\circ \cos(\theta) + \cos(90)^\circ \sin(\theta)]$$

$$T_{CD} \cos(\theta) = 18.8$$

$$0.643 \times 30 = T_{CD} \times \sin(50^\circ + \theta) = 19.284$$

$$30 \times \sin(90^\circ + \theta) = 29.238 \times \sin(50^\circ + \theta)$$

$$\text{But } 30 \times [\sin(90)^\circ \cos(\theta) + \cos(90)^\circ \sin(\theta)] = 30 \cos(\theta)$$

$$\text{and } 29.238 \times \sin(50^\circ + \theta) = 29.238 \times [\sin(50)^\circ \cos(\theta) + \cos(50)^\circ \sin(\theta)]$$

$$\text{or } 22.398 \cos(\theta) + 18.794 \sin(\theta) = 30 \cos(\theta)$$

Solving $\theta = 22.02^\circ$

$$T_{CD} = \frac{18.8}{\cos(22.02)} = 20.278 \text{ kN}$$

Results:

| String | AB | BC | CD |
|-------------|--------|--------|--------|
| Tension (N) | 44.795 | 29.238 | 20.278 |

6. (a) (i) A beam is said to be determinate, if: (A) the reactions can be determined using the equations of equilibrium
(ii) The beam is neither permitted to move in any direction nor allowed to rotate in the case of: (B) Fixed support

540 SOLUTIONS TO THE EXAMINATION PAPERS OF VTU

- (iii) UVL stands for: (D) Uniformly Varying Load
 (iv) A thin rigid beam hinged at one end and roller-supported at its mid-point is said to be:
 (B) a overhanging beam
- (b) Determine the reactions at the supports for the system shown in Figure Q.6(c). Consider the top beam CD

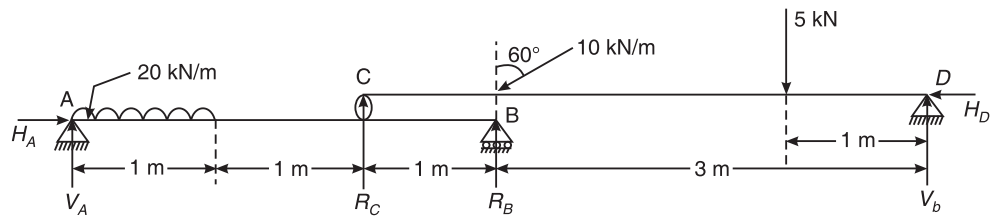

Figure Q.6(c)

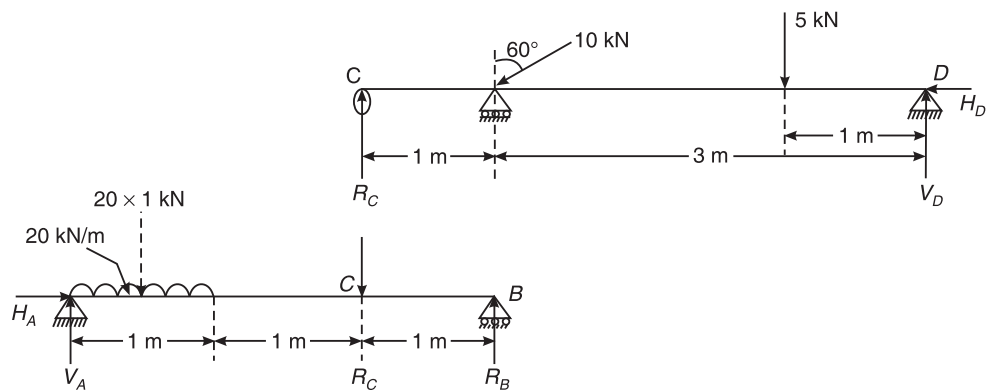

Figure Q.6(c)

From the conditions of equilibrium, we have

Sum of all the horizontal components is zero, i.e. $\Sigma H = 0$

$$H_D = 10 \sin 60^\circ = 8.66 \text{ kN}$$

Sum of all the vertical components is zero, i.e. $\Sigma V = 0$

$$R_C + V_D = 10 \cos 60^\circ + 5 = 10 \text{ kN} \quad (1)$$

Taking moments of all the components about D,

$$4R_C = (10 \cos 60^\circ)(3) + 5 \times 1$$

$$R_C = 5 \text{ kN}$$

Taking moments of all the components about C,

$$4V_D = (10 \cos 60^\circ)(1) + 5 \times 3 = 20 \text{ kN}$$

$$V_D = 5 \text{ kN}$$

Substituting in Eq. (1), we get,

$$5 + 5 = 10 \text{ kN}$$

and hence O.K.

Consider the bottom beam AB

From the conditions of equilibrium, we have

Sum of all the horizontal components is zero, i.e. $\Sigma H = 0$

$$H_D = 0$$

Sum of all the vertical components is zero, i.e. $\Sigma V = 0$

$$V_A + R_B = (20)(1) + 5 = 25 \text{ kN} \quad (2)$$

Taking moments of all the components about B,

$$3V_A = (20 \times 1) \left(2 + \frac{1}{2} \right) + 5 \times 1 = 55$$

$$V_A = 18.33 \text{ kN}$$

Taking moments of all the components about B,

$$3R_B = (20 \times 1) \left(\frac{1}{2} + 5 \times 2 \right) = 20 \text{ kN}$$

$$R_B = 6.67 \text{ kN}$$

Substituting in Eq. (2), we get, $18.33 + 6.67 = 25 \text{ kN}$, and hence O.K.

7. (a) (i) The frictional force is independent of: (A) the area of contact
(ii) Once a body just begins to slide, it continues to slide because: (D) the frictional force becomes less
(iii) The coefficient of friction between two surfaces is the constant of proportionality between the applied tangential force and the normal reaction: (C) at any instant of impending motion
(iv) The angle of friction is angle between: (D) the normal reaction and the resultant
- (c) In Figure Q.7(c), determine the value of P , just required to lift 3000 N up. The angle of friction between block and the wall is 15° , and for other surfaces it is 18° .

Consider the FBD of block. Three forces are acting on the block:

- (i) Weight of block acting vertically downwards
(ii) Reaction with the wall acting at angle ϕ_w with the normal to wall
(iii) Reaction with the wedge acting at angle ϕ_w with the normal the plane $\phi_w = 15^\circ$ and $\phi_b = \phi_g = 18^\circ$

As the system is in equilibrium, Lami's theorem can be applied.

$$\frac{3000}{\sin(\phi_w + 90 + 10 + \phi_b)} = \frac{R_b}{\sin(90 - \phi_w)} = \frac{R_w}{\sin(180 - (10 + \phi_b))}$$

$$R_b = 3962.21 \text{ N and } R_w = 1925.76 \text{ N}$$

542 SOLUTIONS TO THE EXAMINATION PAPERS OF VTU

Consider the FBD of wedge. Three forces are acting on the block:

- (i) Force P acting horizontally
- (ii) Reaction with the ground acting at angle ϕ_g with the normal to ground
- (iii) Reaction with the block acting at angle ϕ_w with the normal the plane

As the system is in equilibrium, Lami's theorem can be applied.

$$\frac{P}{\sin(180 - 10 - \phi_b - \phi_g)} = \frac{R_g}{\sin(90 + 10 + \phi_b)} = \frac{R_b}{\sin(90 + \phi_g)}$$

$$R_g = 3678.46 \text{ N and } P = 2996.85 \text{ N}$$

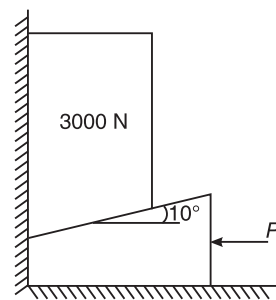
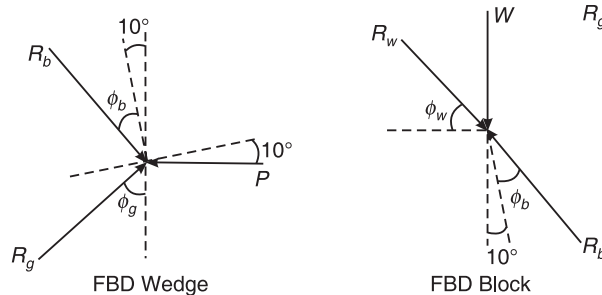

Figure Q.7(c)



8. (a) (i) The moment of inertia of a rectangular lamina of sides b and h about its neutral axis

parallel to the sides b is given by: (B) $\frac{bh^3}{36}$

(ii) The unit of radius of gyration of an area is: (D) m

(iii) The value of moment of inertia depends on: (D) Cross-sectional dimension

(iv) Moment of inertia is a: (C) fourth order term

- (d) Find the moment of inertia of the area shown in Figure Q.8(d) about its centroidal axis parallel to the coordinate axis

Moment of Inertia on centroidal x axis

$$\bar{I}_x = \frac{50 \times 80^3}{12} - 2 \times \left[\frac{\pi(10)^4}{8} \right] = 2125479.35 \text{ mm}^4$$

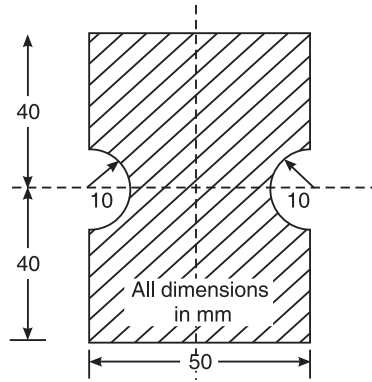

Figure Q.8(d)

Moment of inertia on centroidal y axis

$$\bar{I}_y = \frac{80 \times 50^3}{12} - 2 \times \left[0.11 \times 10^4 + \left(\frac{\pi \times 10^2}{2} \right) \left(25 - \frac{4 \times 10}{3\pi} \right)^2 \right] = 697991.62 \text{ mm}^4$$

INDEX

- Angle of friction (ϕ), 172
Angle of repose (θ), 173
Arch bridges, 20
- Bascule bridges, 16
Beams, types of, 110
Bituminous roads, 8
Branches, 1
Bridges, types of, 13
Building materials, 6
- Cable stayed bridges, 14
Cadastral surveys, 3
Cantilever beam, 111
Cantilever bridges, 18
Cement-concrete roads, 9
Centre of gravity, 211
Centrifugal force, 315
Centroid, 211, 215
Centroidal axis, 213
Circle, 253
City surveys, 3
Civil engineering, 2
Civilization, 2
Classification of trusses, 132
Coefficient of friction (μ), 171
Collinear force, 24, 27
Composite materials, 6
Composition of forces, 28
- Concurrent force, 35
Cone of friction, 174
Construction technology and its management, 5
Continuous beam, 111
Continuum, 23
Coplanar concurrent, 34
 force system, 72
Coplanar force, 24
Coplanar non-concurrent, 51
 force system, 73
Coplanar parallel force, 25
Couple, 32
Curvilinear motion, 296, 310
- Dams, 11
Deformable body, 22
Determination of centroid, 212
Drainage gallery, 12
Dynamic friction, 172
Dynamics, 21, 274
- Earth dams, 12
Engineering, 1
Environmental, 4
Equilibrant, 73
Equilibrium, 72
- Fixed supports, 110

546 INDEX

- Floating bridges, 14
- Fluid mechanics, 3
- Force system, 24
- Force, 23
 - types of, 24
- Foundation, 5
- Free board, 12
- Free-body diagram (FBD), 74
- Friction, types of, 171
- Frictional force, 170

- Geodetic surveying, 2
- Geometrical figures, 215
- Geotechnical, 4
- Gravity dams, 11
- Greatest moment of inertia, 249

- Highways, 7, 9
- Hinged or pinned supports, 110
- Hydraulics, 3

- Infrastructure, 6

- Joints, 133

- Kinematics, 21, 274
- Kinetics, 21, 274

- Ladder friction, 202
- Lami's theorem, 73
- Laws of friction, 174
- Least moment of inertia, 249
- Loads, types of, 111

- Methods of finding the resultant, 29
- Mine surveys, 3
- Moment of a force, 31
- Moment of inertia, 248, 249, 251
- Motion
 - of projectile, 319
 - under gravity, 290
 - types of, 276
- Movable bridges, 16

- Nail, 349
- Newton's laws of motion, 276
- Newton's laws, 23
- Non-collinear force, 27
- Non-coplanar concurrent force system, 26
- Non-coplanar force, 25
- Non-coplanar non-concurrent force system, 26
- Non-coplanar parallel, 26
- Non-rigid truss or deficient truss, 133

- Over rigid truss or redundant truss, 133
- Overhanging beam, 111

- Parallel axis theorem, 249
- Parallelogram law, 29
- Perpendicular axis, 250
- Plane surveying, 2
- Point force, 23
- Polygon law, 31
- Principle of equilibrium, 72
- Principle of superposition, 27
- Principle of transmissibility, 27
- Projectiles, 317
- Propped cantilever beam, 111

- Quarter circle, 254

- Radius of gyration (k), 249
- Rectangle, 251
- Rectilinear motion, 280
- Resolution of a force, 28
- Resultant, 51
- Rigid body, 22
- Roads, 7
- Rockfill dams, 12
- Role of civil engineer, 7
- Roller supports, 110

- Scalar, 23
- Section line, 157
- Semicircle, 253
- Simple supports, 109
- Smart materials, 6
- Static friction, 172
- Statics, 21
- Super elevation, 316
- Support reactions, 109
- Supports, types of, 109
- Surveying, 2, 3
- Suspension bridges, 18
- Swing bridges, 16
- Symmetrical axis, 213

- Timber bridges, 14
- Time of flight, 318

- Topographical surveys, 3
- Transportation, 3
- Triangle law, 30
- Triangle, 251
- Truss bridges, 19
- Trusses, 132

- Uniformly distributed load, 112
- Uniformly varying load, 112

- Varignon's theorem of moments, 31
- Vector, 23

- Water resources, 4
- Wedge friction, 195

ELEMENTS OF CIVIL ENGINEERING AND ENGINEERING MECHANICS

Third Edition

M.N. SHESHA PRAKASH
GANESH B. MOGAVEER

This book, in its third edition, continues to focus on the basics of **civil engineering and engineering mechanics** to provide students with a balanced and cohesive study of the two areas (as needed by them in the beginning of their engineering education). A basic undergraduate textbook for the first-year students of all branches of engineering, this book is specifically designed to conform to the syllabus of Visvesvaraya Technological University (VTU).

Imparting the basic knowledge in various facets of civil engineering and the related engineering structures and infrastructure such as buildings, roads, highways, dams and bridges, the third edition covers the engineering mechanics portion in eleven chapters. Each chapter introduces the concepts to the reader, stepwise. Providing a wealth of practice examples, the book emphasizes the importance of building strong analytical skills. Practice problems, at the end of each chapter, give students an opportunity to absorb concepts and hone their problem-solving skills.

The book comes with a companion CD containing the software developed using MS-Excel, to work out the problems on Forces, Centroid, Friction and Moment of Inertia. The use of this software will enable the students to understand the concepts in a relatively better way.

NEW TO THIS EDITION

- ◆ Introduces a chapter on **Kinematics** as per the revised **Civil Engineering syllabus of VTU**
- ◆ Updates with the **latest examination Question Papers**

THE AUTHORS

M.N. SHESHA PRAKASH, Ph.D., is Vice Principal and Professor of Civil Engineering, Vidya Vikas Institute of Engineering and Technology, Mysore. Earlier, he served as a Professor at Jawaharlal Nehru National College of Engineering, Shimoga. He has over twenty-five years of teaching experience. He obtained his postgraduate degree in Hydraulics and Water Resources with First rank and Gold medal from Mysore University. He has published over 150 technical papers in reputed international and national journals, and presented several papers at international and national conferences. Dr. Shesha Prakash has not only taught civil engineering subjects but also computer subjects like CAD, C and C Graphics, C++, OOPS, etc. He has also designed several software. He has authored books titled *Experiments in Hydraulics and Hydraulic Machines: Theory and Procedures* and *Textbook of Mechanics of Materials* (published by PHI Learning).

GANESH B. MOGAVEER is Professor and Head of Civil Engineering Department, Mangalore Institute of Technology and Engineering, Moodabidri. He has over 19 years of teaching experience and holds a Masters degree in Structural Engineering from Basaveshwara Engineering College, Bagalkot. A member of Indian Society for Technical Education and also a member of the Indian Concrete Institution, he has presented/published several papers in national and international conferences/journals.

You may also be interested in

Engineering Chemistry, 2nd ed., P.R. Vijayasarithy
Engineering Physics, G. Aruldas
Engineering Mathematics, Vol. 1, 4th ed., S.S. Sastry
Engineering Mathematics, Vol. 2, 4th ed., S.S. Sastry
Fundamentals of Electrical Engineering, 3rd ed., Rajendra Prasad
Engineering Graphics for Degree, K.C. John

www.phindia.com



www.engbookspdf.com

**Get more e-books from www.ketabton.com
Ketabton.com: The Digital Library**